

Service Manual

SINGER*

188U31

188U33

188U35

MACHINES

CONTENTS

	Page
Description of Machine	1
Needle Bar	2
To Set Needle Bar at Correct Height	2
To Set Lower Needle Bar Bushing	2
To Set the Check Spring	3
Inspection of Check Spring Height	3
Setting	3
Inspection of Check Spring Tension	4
Setting	4
To Set Presser Bar at Correct Height	5
Setting	5
Hints for Better Feeding	5
To Time Sewing Hook and to Set the Sewing Hook Sidewise in Relation to the Needle	6
Checking and Timing	6
To Time the Feed	7
To Check the Timing	7
To Set Feed Dog at Correct Height	7
To Centralize Feed Dog in Throat Plate Slots	8
Sidewise Setting	8
Lengthwise Setting	8
To Set Thread Clearance Between Position Finger and Bobbin Case Holder	9

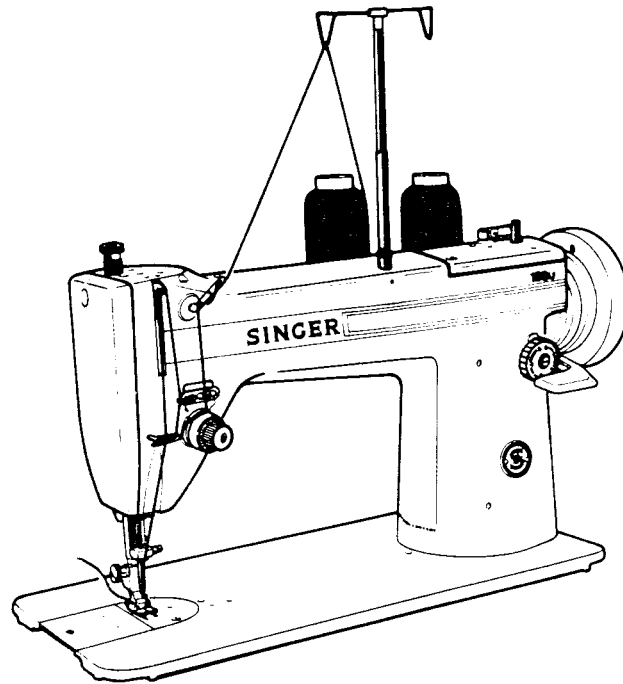

Fig. 1

DESCRIPTION

Class 188U machine produces top quality, single-needle, straight-line lock stitching and back tacking in fabrics ranging from thin muslins to heavy denims and khaki drills.

GENERAL FEATURES:

- . Spring biased, quick-reversible feed mechanism permits operator to feed work forward or backward at will.
- . Oiling point provided on rotary sewing hook assures free and smooth rotation of hook.
- . Link take-up.
- . Grease lubricated gears insure smooth and quiet operation.
- . Maximum stitch length, 5 to the inch.
- . Stitch length controlled by feed regulating dial on front of arm.
- . Machine dimensions; Bed length 15-23/32 inches, width 7 inches. Space at right of needle, 8-9/16 inches.
- . Fitted with clamp type needle bar.
- . Spool pin fitted on rear of arm, permits easy threading.
- . Machine rested on felt pad or rubber pad provided in 4 corners of the well.
- . Hand wheel #546827 provided for foot power machine and hand wheel #546826 for electric drive machine.
- . Bobbin winder built in machine and easy to operate.
- . Knee lifter #505405 regularly furnished.
- . Maximum speed recommended is 2,250 stitches per minutes, depending on the material sewn and type of work being done.

Refer to operator's guidebook, Form U3094 for instructions on oiling, setting the needle, threading, winding the bobbin, regulating the thread tensions, regulating the presser foot pressure, regulating the stitch length, etc.

NEEDLE BAR

There are two timing marks provided on the needle bar. The upper mark A is for setting the needle bar height and the lower mark B is for timing the needle in relation to the sewing hook.

TO SET NEEDLE BAR AT CORRECT HEIGHT:

Remove face plate, slide plate and throat plate. Make sure a suitable needle in good condition is correctly set in needle bar.

Turn hand wheel over toward you until needle bar is at its lowest point. Timing mark A should be level with lower end of lower needle bar bushing C, Fig. 2.

To reset, loosen screw E, Fig. 2. Raise or lower needle bar as required and firmly tighten screw E.

CHECK:

Needle bar is at correct height when hook point passes center of needle approximately .07 inch above top of needle eye, as shown in Fig. 3.

TO SET LOWER NEEDLE BAR BUSHING:

If location of lower needle bar bushing C is disturbed, it will become impossible to use the timing marks.

CHECK:

The Fig. 3 condition must be met first before resetting the bushing.

To set the lower needle bar bushing in the correct position, turn hand wheel until the needle bar is at its lowest position, loosen lower needle bar bushing set screw D, Fig. 2 and raise or lower bushing C as required to bring its lower end exactly level with timing mark A, on needle bar. Securely tighten screw D.

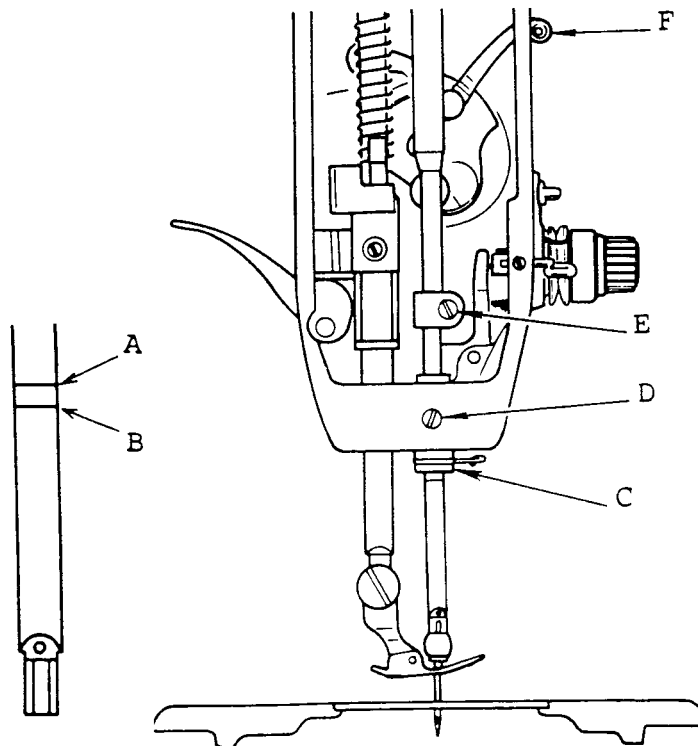

Fig. 2

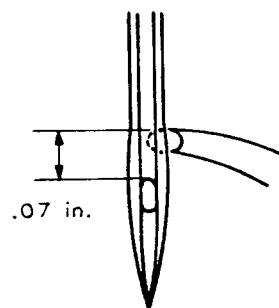

Fig. 3

TO SET THE CHECK SPRING

INSPECTION OF CHECK SPRING HEIGHT:

Inspect check spring height as instructed below.

1. Thread the machine and sew a few rows on two plies of lightweight material.
2. Turn hand wheel over toward you slowly and stop machine when take-up lever F, Fig. 2 ascends to its highest position. At this point the stitch is set and the check spring G should be drawn all the way down, as shown in Fig. 4.
3. As the take-up lever descends and the needle penetrates the material to form the next stitch (Fig. 5-a), the check spring should almost return to its rest position (Fig. 5-b).
4. Just as the needle thread is cast off the sewing hook (Fig. 6), the check spring should make a slight dip.

NOTE: The above conditions may differ slightly depending upon the size of thread used and stitch length.

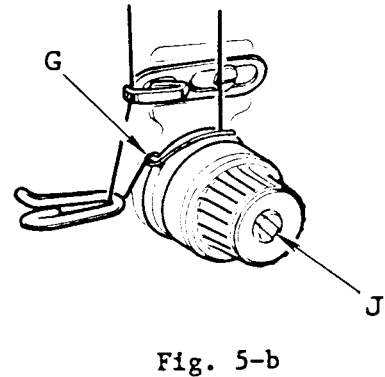
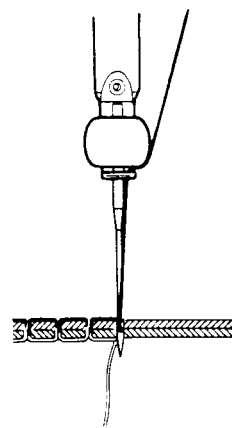
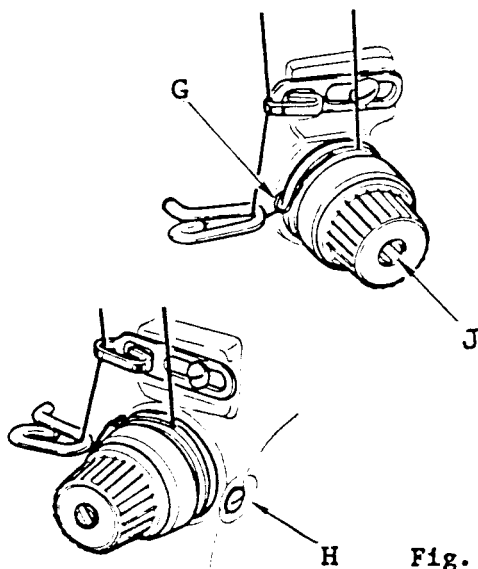

SETTING:

If adjustment of check spring height is found necessary after checking, loosen screw H, Fig. 4 and turn stud J clockwise or counter-clockwise, as required, to correctly set the stop portion of the check spring regulator in position.

When desired movement of the check spring is obtained, firmly tighten screw H and inspect check spring tension.

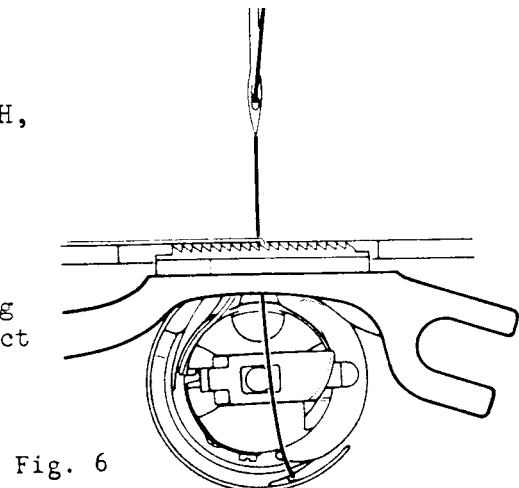

INSPECTION OF CHECK SPRING TENSION:

Tension on check spring G should be sufficient to ensure action at top speed but still light enough to permit itself to be drawn all the way down before any thread is drawn through the tension discs L, Fig. 7 (as take-up lever F, Fig. 2 approaches height of stroke).

NOTE: The tension on the check spring may require different settings depending upon the size of thread and material used. Heavier thread and material require more tension to ensure correct thread control.

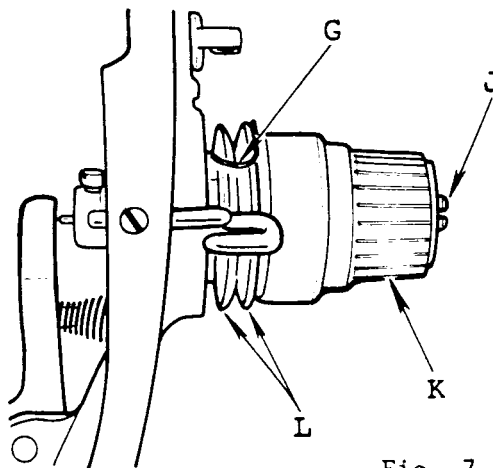

Fig. 7

SETTING:

1. To obtain the correct check spring tension, make certain thumb nut K, Fig. 7 is on stud J.
2. Using a large screwdriver in slot of stud J, turn stud together with check spring G, either to the left to decrease check spring tension or to the right to increase check spring tension.
3. Try sewing two plies of material, balancing the tension between bobbin thread tension and needle thread as instructed on page 12 of the operator's guidebook, Form U3094.
4. The machine should be set to sew with lightest tension possible without loss of thread control.
5. Check for sharp edges on all thread handling parts, such as thread guards and eyelets of thread take-up lever and thread-contact surfaces on tension discs.

TO SET PRESSER BAR AT CORRECT HEIGHT

PREPARATION:

Remove face plate and slide plate.

CHECK:

1. When presser foot rests firmly upon throat plate (with feed dog below throat plate) there should still be some clearance P between guide bracket R and lifting bracket Q, as shown in Fig. 8.
2. When presser foot is at its highest point and needle bar at its lowest, top of presser foot should clear the lower end of needle bar, as shown at T, Fig. 9.

SETTING:

Lower the presser foot. Loosen clamping screw S, Fig. 8. Raise or lower guide bracket R as required. Make certain presser bar is positioned correctly so that needle will locate centrally between the two toes of the presser foot. Securely tighten screw S.

HINTS FOR BETTER FEEDING:

Test presser bar for smooth, uniform motion. If presser bar tends to stick at any point in its stroke, feeding will be adversely affected.

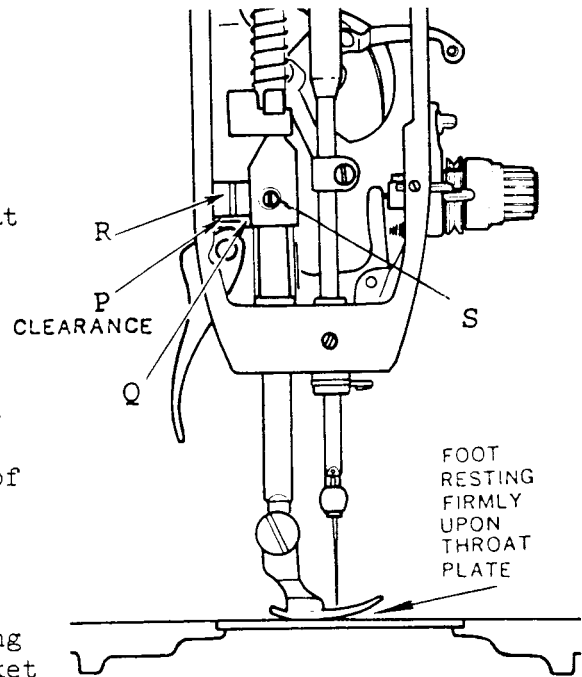

Fig. 8

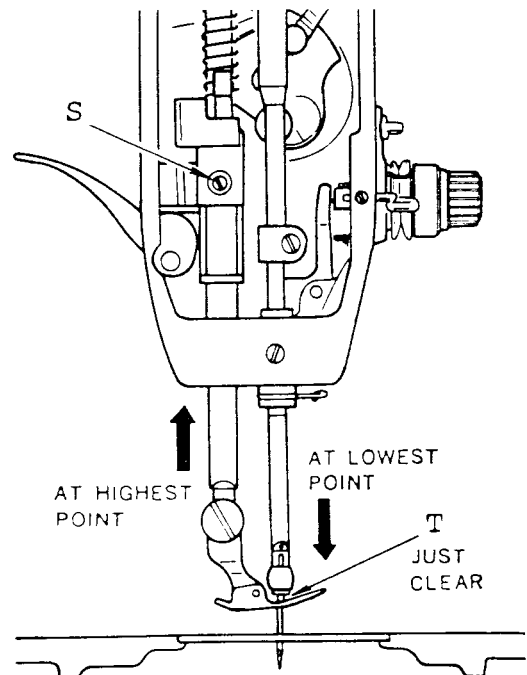

Fig. 9

TO TIME SEWING HOOK AND TO SET
THE SEWING HOOK SIDEWISE IN RELATION TO THE NEEDLE

PREPARATION:

Set needle bar at correct height as instructed on page 2. Remove presser foot, slide plate, throat plate and feed dog.

CHECK:

When timing mark B, Fig. 10 on needle bar is level with lower end of lower needle bar bushing C, the point of sewing hook should be at the center of the needle as shown at V, Fig. 10.

Clearance between point of hook and needle when point of hook passes needle should be 0 to .002 inch.

NOTE: Make sure not only the hook point but the flat provided on the hook point also clears the scarf on the needle blade when the point of hook passes the needle.

Normally a clearance of .010 inches is provided between the end of hub of the hook and hook shaft bushing (front) X Fig. 11.

TIMING:

Loosen the 2 sewing hook set screws W, Fig. 11 Retighten 1 of the 2 screws until resistance is felt.

Turn hook in relation to hook shaft so that point of hook is at center of needle as shown in Fig. 10. Simultaneously adjust clearance between point of hook and needle.

Tighten the 2 set screws lightly and check to see that timing and clearance of hook point to needle etc., is properly set by turning hand wheel slowly.

Securely tighten the 2 set screws.

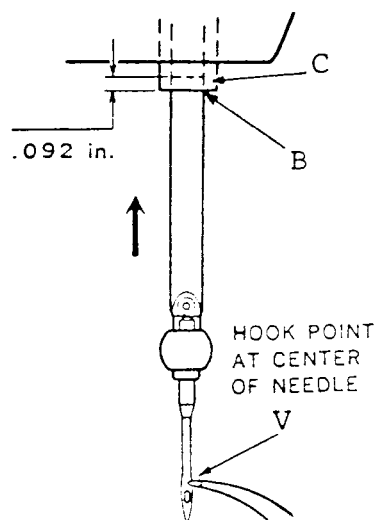

Fig. 10

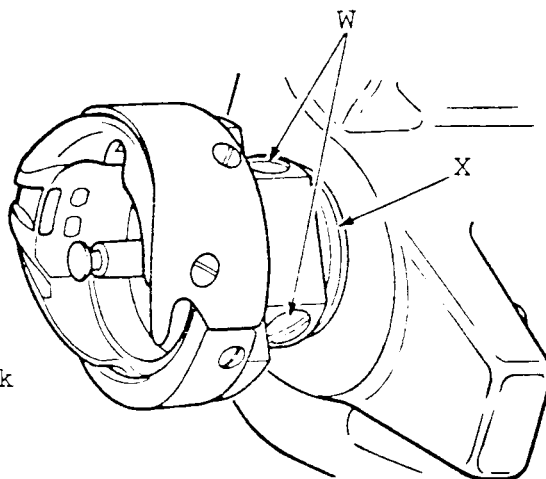

Fig. 11

TO TIME THE FEED

Loosen three screws and remove arm side cover. Turn hand wheel over toward you until needle bar is at its highest position. Screw F1, facing outward as shown in Fig. 12, is the timing screw.

TO CHECK THE TIMING:

Before the machine leaves the factory, the feed and feed lifting eccentric G1, Fig. 12 is correctly set for average sewing conditions by having the timing screw F1 securely tightened over the timing line E1, Fig. 12 on the arm shaft (horizontal).

When correctly timed

1. The feed dog should stop moving toward the rear just as the take-up lever reaches the top of its stroke.
2. The feed dog should have dropped below surface of throat plate just as needle is about to enter needle hole in throat plate.

If for any reason, it may be necessary to alter the timing of the feed

1. Loosen screws D1 and F1, Fig. 12, in feed and feed lifting eccentric.
2. Turn feed and feed lifting eccentric G1 on arm shaft, as required.
3. Securely tighten screws D1 and F1.

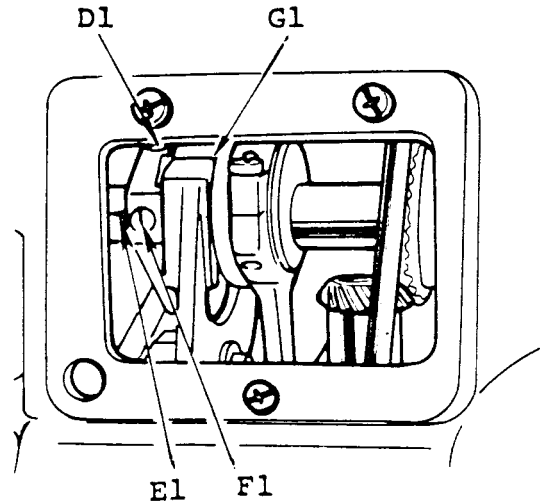

Fig. 12

TO SET FEED DOG AT CORRECT HEIGHT

When the feed dog H1, Fig. 13, is at its highest position, the rear teeth of the feed dog should project above the top surface of the throat plate, as shown in Fig. 13, at a height of .040 to .043 inch.

The feed dog height may sometimes require to be changed depending upon the thickness of material sewn.

Before checking height of feed dog, set stitch length regulator for longest stitch.

To adjust the height of the feed dog, loosen screw J1, Fig. 13 and raise or lower feed bar M1 with feed dog H1, as required.

Securely tighten screw J1.

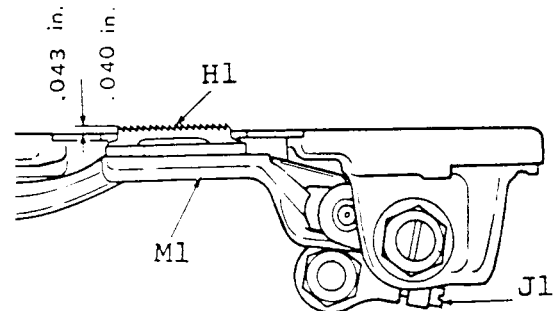

Fig. 13

TO CENTRALIZE FEED DOG IN THROAT PLATE SLOTS

CHECK:

Feed dog should not contact edges of throat plate slots.

SIDewise SETTING:

1. Feed dog can be moved toward left or right, as required, after loosening two nuts L1 on screw centers K1, Fig. 14.
2. To move feed dog toward left, loosen screw center K1 at left end of feed rock shaft N1, Fig. 14, as required, and tighten the other screw center an equal amount.
3. To move feed dog toward right, loosen screw center K1 at right end of feed rock shaft N1, as required, and tighten the other screw center an equal amount.

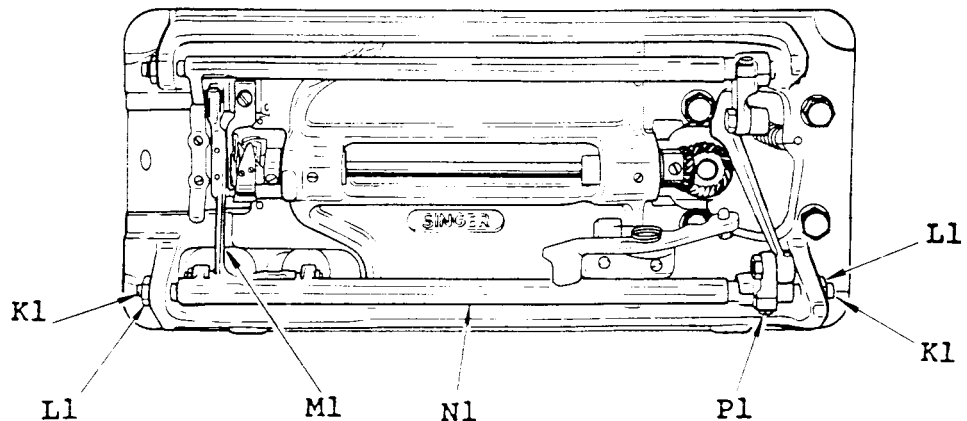

Fig. 14

4. Feed dog should travel midway between sides of throat plate slots.
5. Screw centers must hold feed rock shaft N1 snugly in place without binding.
6. Securely tighten both nuts L1.

LENGTHWISE SETTING:

1. Set machine for longest stitch as instructed earlier.
2. Feed dog should be set so that its movement is equidistant from front and rear edges of throat plate slots.
3. Loosen clamping screw P1, Fig. 14 and move feed bar M1 and feed rock shaft N1, as required.
4. Securely tighten screw P1.

TO SET THREAD CLEARANCE BETWEEN
POSITION FINGER AND BOBBIN CASE HOLDER

Make certain position finger S1 of bracket R1 enters notch T1 at top of bobbin case holder, as shown in Fig. 15.

Thread clearance between bobbin case holder and position finger S1, Fig. 15 must be set at approximately .018 to .022 inch and clearance between bobbin case holder and side edges of bobbin case position finger should be .025 to .029 inch, so that there is free passage for the needle and bobbin threads while the loop of the needle thread is being passed around the bobbin case. There also must be sufficient "checking" of bobbin thread at completion of stitch.

To set clearance between notch T1 and position finger S1, loosen screw Q1, Fig. 15 and move bracket R1, as required. It may be necessary to bend position bracket carefully to suit the required conditions. When position finger S1 is correctly set, make certain fastening screw Q1 is securely tightened.

NOTE: When position of sewing hook has been changed, these clearance must be rechecked.

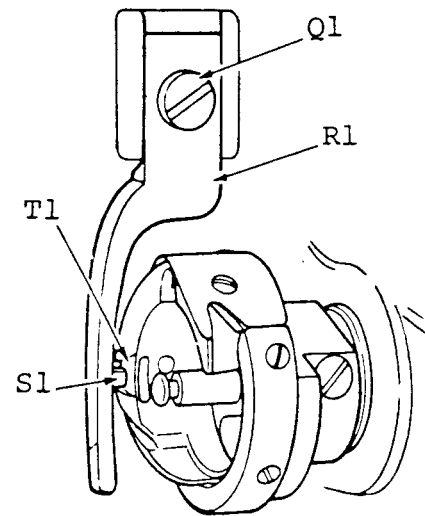

Fig. 15