

SINCERE'S
SEWING MACHINE
Service **BOOK**

\$ 9.95

SINCERE'S
SEWING MACHINE
Service **BOOK**

by
WILLIAM EWERS

with
H.W. Baylor
and
H.H. Kenaga

PUBLISHED BY
SINCERE PRESS
POST OFFICE BOX 10422
PHOENIX, ARIZONA 85018

Introduction		Page 3
Chapter One	The Long Shuttle, Singer 127-128	Page 8
Chapter Two	The Class 15 Oscillator Singer Class 15-30 Singer Class 15-88 to 15-91 Japanese HA-1 Japanese Streamlined, covers most machines, Sears, Wards, White etc. Riccar RW-8	Page 29
Chapter Three	The Class 66 Oscillator Singer 66-1 to 66-18 Japanese machines with 66 type Top-loading bobbin.	Page 54
Chapter Four	The White Rotary, American Made	Page 63
Chapter Five	Manual Zig Zag, Riccar Manual Zig Zag, other Japanese	Page 81 Page 91
R 681.76462 EWE 307098 17. 8. 71 CANTERBURY PUBLIC LIBRARY	Chapter Six The Automatic Zig Zag The Pfaff, Models 260-360 The Pfaff, Model 130 The Viking(Husqvarna) Riccar Model RZ304B Riccar Model 777 The Adler The Elna	Page 96 Page 96 Page 117 Page 121 Page 139 Page 152 Page 164 Page 173
Chapter Seven	Miscellaneous Sewing Machines	Page 178
Chapter Eight	Electrical Equipment	Page 182
Chapter Nine	Attachments	Page 191
Chapter Ten	Singer Model 201, Model 221. White, Japanese Made Troubleshooting guide	Page 196 Page 198 Page 203

First Edition

First Printing: November 1968

Second Printing: April 1969

Second Edition

First Printing: March 1970

Printed in the United States of America

All Rights Reserved

Copyrights, 1968, 1970, by Sincere Press

Introduction

We trust this sewing machine repair book will fulfill our intended goal, and give the average housewife a deeper insight into the most abused and misunderstood appliance in her home, and secondly, to encourage more young men to adopt sewing machine repair as a trade.

Home sewing is experiencing a dramatic upsurge. Despite the so-called generation gap, more teen-age girls are making their own clothes than ever before. Most schools report their sewing classes are full, with more girls clamoring to get in. Although many schools buy the latest sewing machines, service is another matter. With the possible exception of Singer, service to schools is sporadic. This service book can enable the sewing teacher to service her own machines, and more important, teach her students to do the same.

New methods of marketing have changed the industry. Almost without exception the trend is sell, sell, sell. In bygone days, when sewing machine men started with White, Singer, Free-New Home, or National, they learned the business from the back room forward.

Today, very few men venture into the back room, and many don't know what a screwdriver looks like.

Singer is the only company still manufacturing sewing machines in the United States, and they're so diversified that sewing machines are almost a by-product.

The industry is in dire need of renewed interest in good honest service and pride of workmanship. Most companies furnish service manuals for their machines, but the manuals are generally denied the free-lance repairman.

Our book represents ten years of writing and constant up-dating, in an attempt to bring good repair methods to most sewing machine owners, or men interested in learning a profitable trade.

Since 1850, thousands of different sewing machines have been made. Sincere's book covers a cross section of the more popular makes, concentrating on imports and automatic zig zags, because of need in that area. The book is a condensation of a home study course, currently under consideration by the Job Corps for inclusion in their curriculum.

What is our authority for writing this book? A total of 80 years with every major sewing machine company in the United States, plus successful independent dealerships, should suffice.

H. W. Baylor started with the Singer Company in 1933, as a sales trainee, became assistant manager in 1935, then moved to San Francisco, where he was manager of the Mission store, and eventually, all Peninsula stores.

World War II curtailed all sewing machine making, so Baylor returned to independent status until 1947, when he returned to Phoenix, Arizona, as manager for the White Sewing Machine Company.

Herb Kenaga joined him, and they set up a complete rebuilding shop. It was here they trained young repairmen, under the GI training program.

Baylor remained with White, in Arizona, until 1950, when he was promoted to District Manager of the Southern California district. Baylor moved to Los Angeles. Imported machines were cracking the domestic market, but White didn't seem to care, so he left the company and returned to Arizona.

He opened the Sincere Sewing Machine Company, became the dealer for Bel-Air and Adler machines. Later he obtained the Viking franchise and remained a top dealer in the southwest for years.

Herb Kenaga began his illustrious career with the White Company as a oiler and set-up man. He joined Singer in 1935. Later he managed Singer stores in Prescott, Arizona, and Klamath Falls, Oregon.

He left Singer during World War II, and set up a repair and rebuilding shop. Wartime shortages made it necessary for Herb to build many of his parts. His knowledge of the industry ranks him near the top of sewing machine repairmen in the United States.

After his tenure with Baylor in Phoenix, he returned to Oregon and opened one of the first Pfaff dealerships in this country. Later, he set up new dealers for Pfaff, in Western Canada. He eventually started his own chain of stores in the Territory of Alaska. Herb probably has the distinction of selling the first sewing machine above the Arctic Circle. Many of his calls were made with bush pilots to the wild, remote villages of that ruggedly, beautiful state.



The combined experience of H. W. Baylor, and H. H. Kenaga, together with my ten years in the trade, make up the technical knowledge, with help from Riccar America, Pfaff distributors, White Consolidated Industries, and many other independent dealers around the Country.

We wish to thank all the sewing machine men who helped this venture.

William Ewers

How To Identify Your Sewing Machine

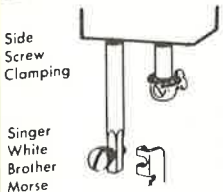
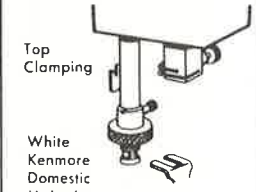
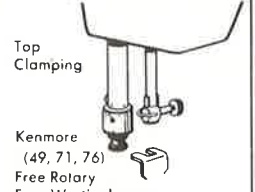
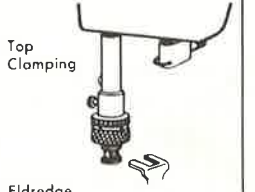
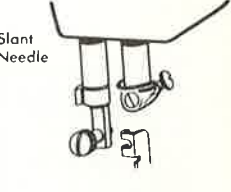
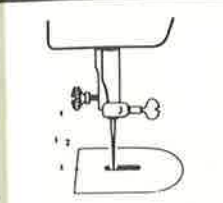
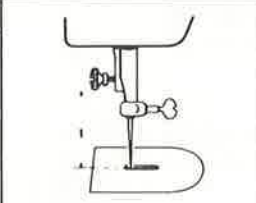
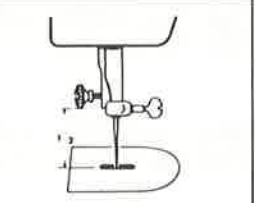
The illustration below shows how to identify your machine by method of presser foot attachment.

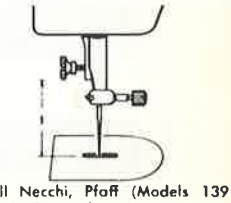
#1	#2	#3	#4	#5
 <p>Side Screw Clamping</p> <p>Singer White Brother Morse Atlas Kenmore Domestic Free Westinghouse and most all imported straight stitch sewing machines</p>	 <p>Top Clamping</p> <p>White Kenmore Domestic Majestic Franklin Worlds Dressmaster and all Rotary machines made by White & Domestic Sewing Machine Corp.</p>	 <p>Top Clamping</p> <p>Kenmore (49, 71, 76) Free Rotary Free Westinghouse New Home (Rotary) Stratford Most all machines made by Free & New Home Sewing Machine Company</p>	 <p>Top Clamping</p> <p>Eldredge National Montgomery Ward All machines made by National Sewing Machine Company</p>	 <p>Slant Needle</p> <p>Singer only.</p>
<p>ILLUSTRATIONS #6 to #10 — If you have a ZIG-ZAG or AUTOMATIC SEWING MACHINE . . . set your machine for straight stitching with needle down in needle plate. Lower presser foot. Measure distance from needle plate to bottom of screw that holds presser foot (as shown). It will measure either 1/2" or 1" (see illustrations). This will determine whether your machine is a low bar (1/2") or a high bar (1"). Now check position needle enters plate (see illustrations).</p>				
#6	#7	#8	#9	#10
 <p>Low Bar — Left Needle Position Zig Zag and Automatic Machines</p>	 <p>High Bar — Left Needle Position Zig Zag and Automatic Machines</p>	 <p>All Pfaff Sewing Machines except models 139 and 239</p>	 <p>All Necchi Straight Stitch and all Low Center Needle Position Zig Zag and Automatic Machines.</p>	 <p>All Necchi, Pfaff (Models 139 and 239) and High Bar Center Needle Position Zig Zag and Automatic Machines.</p>







General Guide for proper needle usage.

Size of Needles	C l o t h	Size of Thread
No. 9	Thin calico, silk, serge, and muslin.	No. 100-150 cotton thread or fine silk thread
No. 11	Thin calico, cotton cloth, crepe de chine, hosiery, and silk.	No. 80-100 cotton thread or ordinary silk thread
No. 14	Ordinary cotton cloth, thick silk thin woolen goods, towels & shirting.	No. 60-80 cotton thread or ordinary silk thread
No. 16	Thick cotton cloth, serge and thin woolen goods.	No. 40-60 cotton thread or ordinary silk thread
No. 18	Ordinary woolen goods, teousers, overcoats, thick calico, and children's clothes.	No. 30-40 cotton thread or ordinary silk thread
Twin Needle No. 14	Calico, silk, serge, cotton cloth and thin woolen goods.	No. 40-80 cotton thread or ordinary silk thread

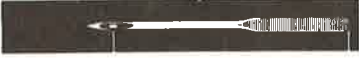
Interchangeable Needle List

MACHINE	TYPE	MACHINE	TYPE
ABC LIFETIME	AA	Domestic Rotary	AA
ADMIRATION	AA	DOTGLAS	AA
American	BB	DRESSMAKER	AA
American No. 7	FF	DRESSMASTER	AA
AMERICAN NATIONAL	AA	Economy	AA
AMBASSADOR	AA	Edgemere	BB
ALLEN'S	AA	EDISON	AA
AMERICAN HOME	AA	ELITE	AA
ANGELA	AA	ELNA	AA
ANKER	16x87	EMERSON	AA
ARMAND	AA	EMPORIUM	AA
ATLAS	AA	El dredge Vibrator	BB
Arlington	AA	El dredge Rotary	DD
Arrow	AA	ELGIN	AA
Aviator	AA	FERGUSON	AA
Banner	BB	Favorite	AA
Bartlett	BB	FLEETWOOD	AA
Bartlett Rotary	DD	Florence	BB
Belvidere	BB	Florence Rotary	AA
BELVADERE ADLER	AA	Foley & Williams	BB
BREWER	AA	FOWLER	AA
Brewer Rotary	CC	Franklin Rotary	CC
BROTHER	AA	Free	AA
Bruce Rotary	AA	Free Rotary	CC
Brunswick Rotary	DD	FREE-Westinghouse Jap.	AA
CENTRAL	AA	FREE-Westinghouse Rotary AM.	CC
CENTURY	AA	GEM	AA
CLARK'S	AA	General Electric	CC
Champion	BB	GOOD HOUSEKEEPER	AA
Cleveland	AA	Graybar	BB
Climax	BB	Graybar Rotary	DD
Columbian	AA	Greyhound	AA
CORONET	AA	Greyhound	CC
Cottage	BB	GRISMORE'S	AA
CUSTOMATIC	AA	GOLDEN RULE	AA
Damascus	BB	HEER'S	AA
Damascus Rotary	DD	Helpmate	GG
Davis Long	FF	HEYDE	AA
Davis Short & Rotary	AA	HESS	AA
DELTA	AA	Improved New Royal	AA
Diamond	BB	IMPERIAL	AA
Domestic N.S. & O.S.	CC	Improved New Cottage	BB

SAMPLE TYPES OF NEEDLES

15 x 1 AA		20 x 1 BB	
W.W. EE		Davis Long FF	
N.Dom. GG		Eld. Pat. DD	
HH			

MACHINE	TYPE	MACHINE	TYPE
Kantauk	BB	POWERS	AA
KENMORE ROTARY	AA	PRECISION	AA
Kenwood	BB	PREMIER	AA
Kenwood Rotary	DD	PRICILLA	BB
KERLICK	AA	QUALITY	AA
KINGSTON	AA	RELIABLE	AA
LIBERTY	AA	REVERE	AA
Majestic	AA	RAINS	AA
Manson Rotary	AA	REMINGTON	AA
MITCHELL	AA	RICCAR	AA
Minnesota	FF BB, AA	ROSHK'S	AA
MODERN	AA	Ruby	AA
MODERNAGE	AA	SEARS ROEBUCK	AA
MODERN HOME	AA	SENIOR	AA
McKEE'S	AA	Singer	AA
MODERNAIRE	AA	SPARTAN - Gr. Britain	AA
Montgomery Ward O.S.	BB	STRADIVARO	AA
MONTGOMERY WARD	AA	S.B.F. DELUXE	AA
National	BB	SOVEREIGN	AA
National Rotary O.S.	DD	TRANS WESTERN	AA
NECCHI	AA	UNIVERSAL	AA
New Century	AA	UNITED	AA
New Century Rotary	CC	ULTRAMATIC	AA
New Companion	BB	Velox	BB
New Cottage	BB	Vindex	BB
New Damascus	BB	VICTOR	AA
New Domestic	GG	VALIANT	AA
New Florence	BB	VOGTE STTCH	AA
New Florence Rotary	AA	WESTERN	AA
New Home O.S. Vih.	BB	Western Electric	BB
New Home Rotary AM.	CC	Western Electric Rotary	DD
NEW HOME Jap.	AA	Westinghouse Rotary	CC
New Model	BB	Wheeler Rotary	CC
New National	AA	Wheeler & Wilson	EE
New Royal	AA	Whippet	AA
New Willard	AA	Whippet Rotary	CC
NORTON	AA	WHITE	AA
ODEN'S	AA	WESTERN	AA
Pahfinder	FF	Windsor	BB
Pearless	AA	WIZARD	AA
PFAFF	130R	World Rotary	AA
		YOUNKER'S	AA

Chapter One

The Long Shuttle Sewing Machine

Every lockstitch sewing machine operates in the same general manner. Individual manufacturers may have a different slant on certain methods of operation, but basically, all sewing machines sew alike.

The upper thread unwinds from its spool on the spool pin on the upper arm of the machine, passes through a series of guides, into a pair of discs which are controlled by a positive control nut, or dial, called the tension through a thread controlling check spring, into the take-up lever, and downward into the needle.

The lower thread is wound on the bobbin(lower thread holder), inserted into the shuttle, and the shuttle placed in the shuttle carrier. When the machine runs, the threads are joined in the cloth, forming a lockstitch. With coordinating motion, the feed section moves the cloth in harmony, making each stitch the same length. The feed system also keeps the cloth moving in a straight line.

There are three basic type sewing mechanisms in the lockstitch category. First and simplest is the vibrator class(long shuttle). Vibrator machines are relatively simple to operate, but have many limitations.

The second type is the Oscillating hook. There are several varieties of this type, with the class 15, and class 66, the most popular. Most are round bobbin machines. They are the most dominant system in the market today. Japanese manufacturers seem to prefer the Class 15 system.

Last, but not least, is the Rotary shuttle. Many rotaries have been manufactured, but White made the name popular by incorporating it into their trademark. Together with the Wheeler Wilson, White was a leader with their rotary system, until the era of high speed Singer, and imported machines. The rotary mechanism is generally smoother and quieter, than the other types.

Sewing machines come in all sizes, shapes, colors and names, but each fits into one of the three types.

Fig. 1. Shuttle assembly: Long Shuttle, Oscillator, and Rotary types.

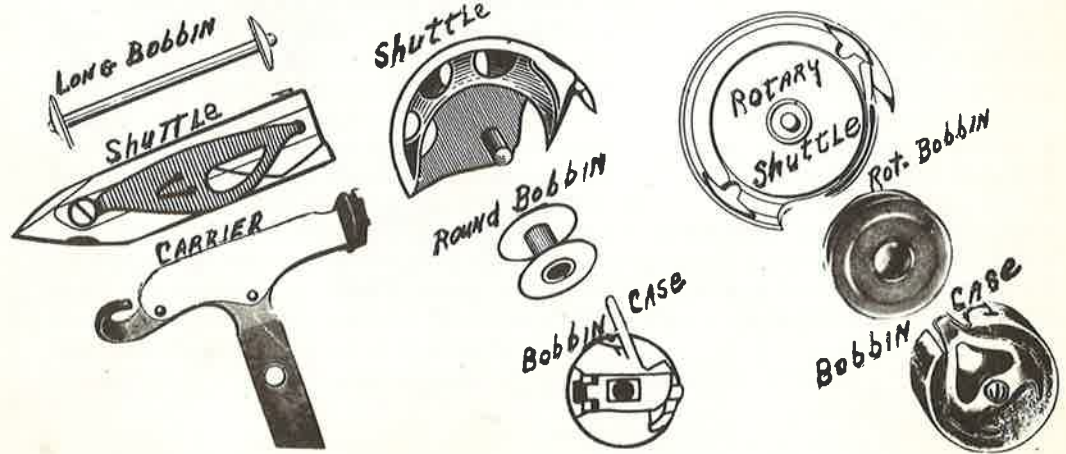

Interchangeable Needle List

Figure 2

©

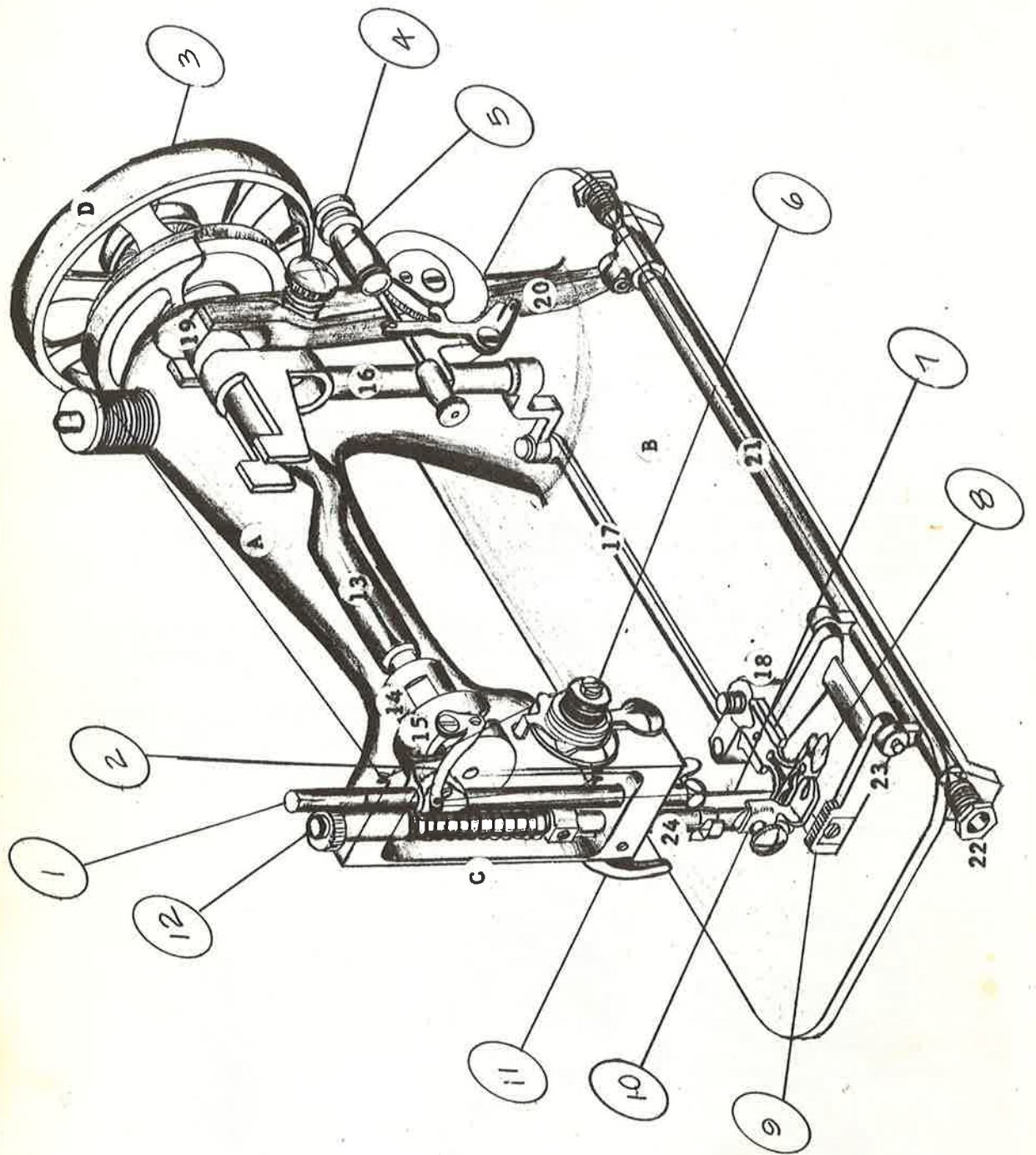

Component list for the Long Shuttle

A. Arm

B. Bed

C. Face section

D. Hand or Balance Wheel

1. Needle bar. Moves the needle up and down.
2. Take-up arm. Controls thread during stitch construction.
3. Clutch. Disengages machine for winding the bobbin.
4. Bobbin winder. Winds thread on lower thread holder.
5. Stitch regulator. Adjusts length of stitch. Later models feature a reverse mechanism.
6. Tension assembly. Controls and regulates upper thread tension.
7. Needle. Carries upper thread down through the cloth so the shuttle can pick it up and complete the stitch.
8. Shuttle. Holds bobbin and lower thread, cycles with needle to sew.
9. Feed dog. Moves cloth from underside.
10. Presser foot. Presses against cloth from upper side, helps guide material in a straight line.
11. Presser bar lifter. Lever for raising or lowering presser bar.
12. Cap adjusting screw. Controls degree of pressure on presser foot.
13. Main shaft. The entire sewing mechanism is activated by the main shaft. It is held in place by main bearing (14) at the left end of the arm and in the cast itself at the extreme right.
The take-up arm (2) works in a groove cut in main cam (15), moving up and down controlling the thread as the main cam spins on shaft. The cam also activates the needle bar (1), moving it up and down, roller cam and bracket in harmony with the take-up arm.
Lower sewing mechanisms are activated when the rocker shaft (16) turns on the main shaft and moves the shuttle driving bar (17) in conjunction with the bell crank (18). The bell crank is the pivotal point for the entire lower sewing mechanism. It moves the shuttle carrier and shuttle, and at the same time, by means of a roller cam and race way, controls the feed timing in relation to stitch forming. The feed drops when needle enters the cloth, then rises to move the cloth when the needle returns to it's starting point.
Caution: Never pull material when needle is down.



19. Feed eccentric cam. Attached to the main shaft next to the rocker arm it activates the feed fork(20), is controlled by the stitch regulator (5) as it moves the lower feed bar(21) to activate the entire lower feed system.
23. Feed raising bar. It is held in place by two tapered adjustable screws one at each end of the bar. One side is attached to the feed bar and the other contains the roller and stud assembly that travels in the eccentric groove of the bell crank. The feed dog is also attached to the feed raising bar.

Incorrect timing of feed and sewing operations can be traced to this area.

Proper timing occurs when lowered needle and shuttle point combine to intertwine both threads and lock them firmly in the material. During this period, the feed dog is inert with teeth just below needle plate surface. After lockstitch is formed and both needle bar and take-up arm are up, the bell crank activates the cam and feed raising bar assembly and moves the feed dog up, from front to back and moves the material. At this time the shuttle is inert, resting at the rear of the race until the bell crank recycles. The feed drops and the shuttle is reactivated, starting forward to meet the needle and form the next stitch.

24. Presser bar. The presser bar contains vehicles for controlling top pressure on cloth and holding presser foot or various attachments for different sewing applications.

What makes a sewing machine sew? Figures three through ten traces the various steps each thread must take en route to forming a perfect stitch.

Figure 3. The upper thread unwinds from it's spool, is threaded through guide A, into tension B, check spring C, into take-up lever D, into guide E, needle clamp and into needle eye G.

Always raise the presser bar with lifter before threading the sewing machine. This step releases the pressure on the tension discs and allows thread to be pulled through without breaking. See figure 4.

Check needle for proper placement. The flat side always goes to inside on this type sewing machine. Easiest way to check out proper placement is on the needle itself. Thread always threads into needle eye from grooved side.

Scarf always faces shuttle point.

The scarf is the slight indentation on needle above the eye.

Figure 3

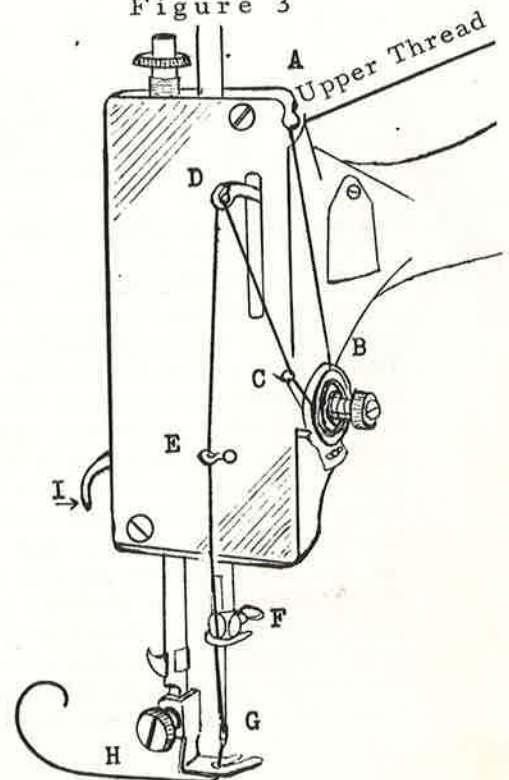

Figure 4

Figure 4. To pick up the lower thread, the operator turns the balance wheel toward her with the right hand and holds the upper thread loosely in the left.

As she turns the wheel, the needle enters the needle hole, drops to a point below shuttle point, hesitates and starts back with a loop extending for shuttle to catch. The upper thread slides along the shuttle, picking up the lower thread as the shuttle cycles.

When operator completes one turn of balance wheel, both threads should return through the needle hole, as she flips the upper thread.

A thread cutter is attached to the presser bar. The operator then slips both threads over the cutter to slice off excess thread.

Check machine before test sewing. If thread guides or the needle clamp guides are broken, replace them.

If the needle clamp screw is broken or missing, it must be replaced since it acts as the upper stop for needle. Machine will generally skip stitches when stop screw is missing.

The proper needle for Class 27, 127 and 128 Singer is the 15 x 1.

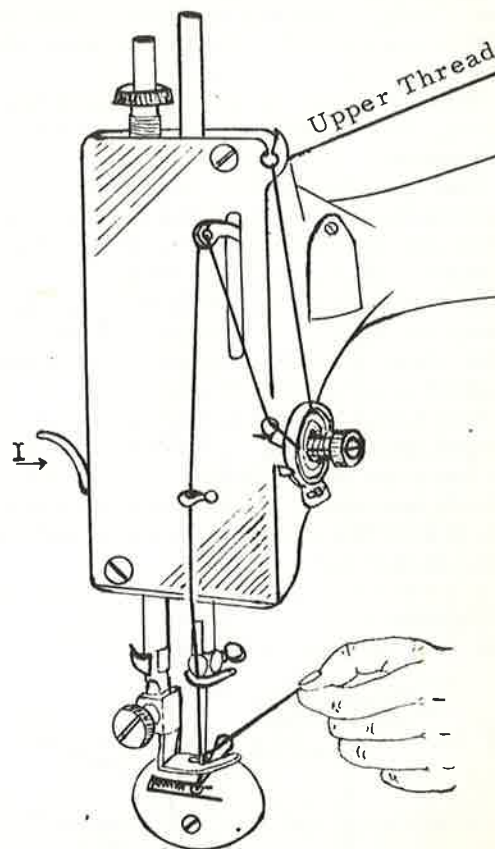

Figure 5

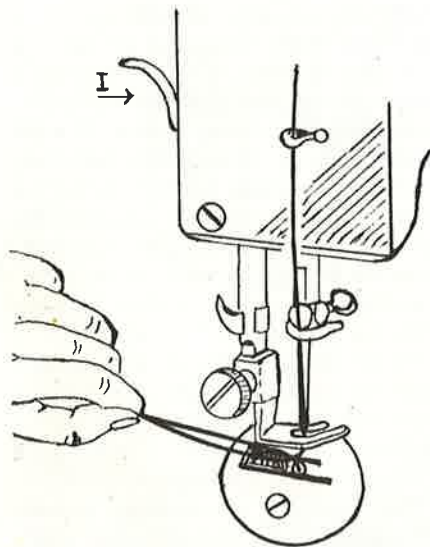

Figure 5. After the threads have been pulled free and cut to proper length, the operator pulls them back thru the presser foot, under and toward the rear of the machine.

When the threads are in this position and the presser foot is lowered onto the material, the foot acts as a lock until the first three or four stitches are formed.

To avoid unthreading the machine, the take-up arm should be at its highest point. See figure 4.

Be sure presser bar is properly adjusted for material being sewn. Turn adjusting screw down for more pressure, up for less. Check presser foot for proper alignment.

Figure 6. The first step in making a stitch shows the needle descending into the cloth. When properly adjusted, the check spring releases the thread when the needle enters the cloth.

The take-up arm drops to its lowest point, hesitates and causes a loop to be thrown in the upper thread.

The shuttle starts forward, its point passes over the eye of the needle, into the loop and continues onward as the upper thread slides along the shuttle body.

If the upper thread has a tendency to jump or act in an erratic manner during this stage of stitch forming, remove the shuttle and inspect it closely.

Since the thread does travel its entire length on each stitch, there may be a mar or burr on the shuttle. It's essential to check near rear of shuttle where the constant rubbing against the race will wear a hole in the part.

Caution: Any broken or marred part, should be replaced immediately. See text on troubleshooting.

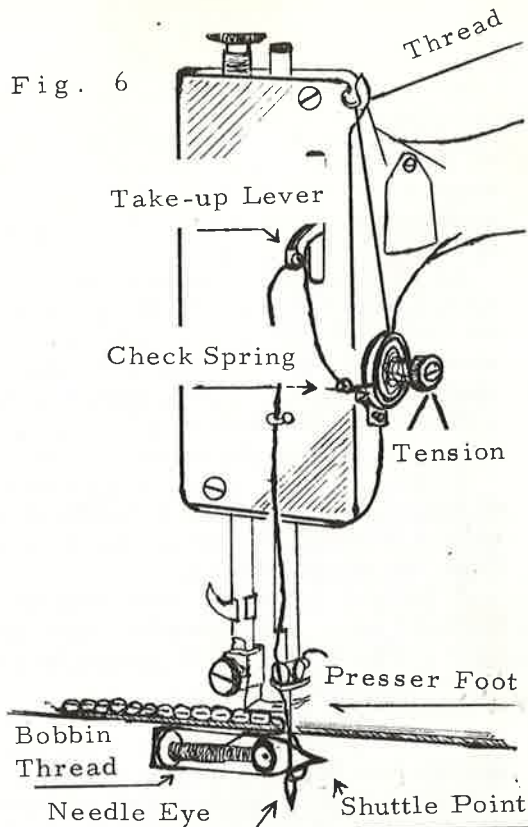

Fig. 6

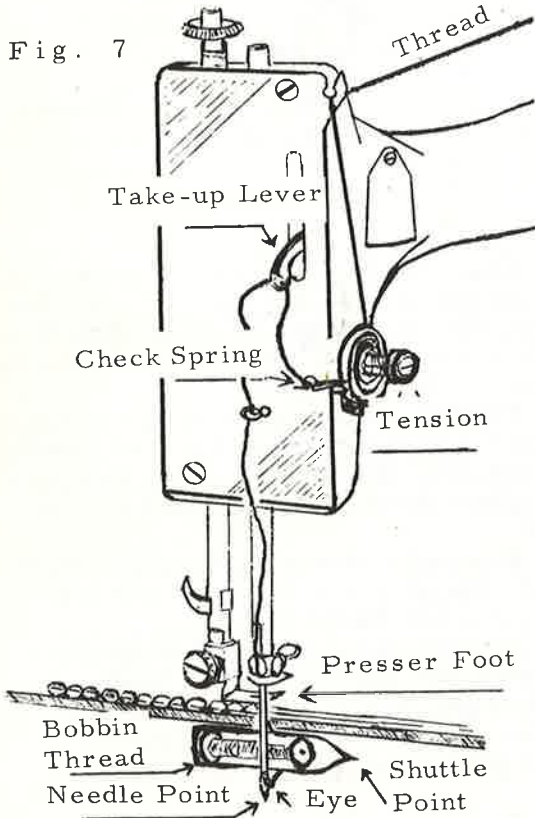

Fig. 7

Figure 7. As the cycle continues, the needle starts upward, pulling the upper thread and bringing the lower thread with it.

The bobbin spins in the shuttle, dispensing the required amount of thread to form a perfect stitch.

To maintain proper stitching, it's essential that the bobbin be properly wound. If the bobbin winder doesn't function properly, the thread will pile up and distort stitching since it will not unwind evenly from the bobbin.

The bobbin should turn freely in shuttle, just as the shuttle should be free as it rests in the shuttle carrier.

Tolerances aren't too close on long shuttle machines and a little harmless rattle is no cause for alarm.

Motorized long shuttle machines are prone to rattle since they generally sew faster than the manufacturer originally intended. This applies to converted machines.

If the machine is too noisy, there are adjustments on the shuttle carrier to compensate for it.

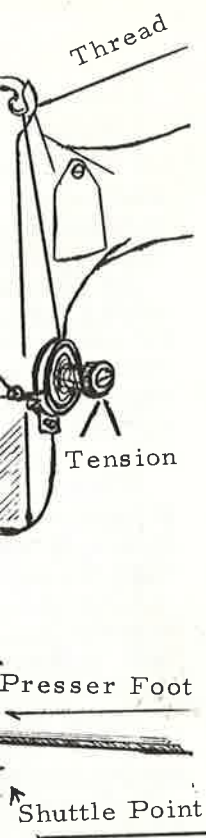

cycle contin-
ward, pulling
ng the low-

the shuttle,
ed amount of
t stitch.
stitching, it's
n be properly
inder doesn't
read will pile
g since it will
n the bobbin.
urn freely in
ttle should be
uttle carrier.
o close on long
a little harm-
for alarm.
ttle machines
nce they gen-
the manufact-
ed. This app-
ines.
o noisy, there
e shuttle car-
r it.

Figure 8. The needle returns through the cloth as the shuttle arrives at the end of its forward cycle. The take-up arm moves upward in rhythm with the needle bar, tying the threads together as the sewing cycle moves toward a climax.

The feed bar begins to move as the roller and cam assembly are activated by the bell crank.

As the feed bar moves, the feed dog starts to rise in the front end of needle plate slots, in preparation for moving the cloth.

The take-up lever continues upward.

The check spring starts its holding action on the top thread as the stitch nears completion.

The needle continues upward and draws the two threads taut.

Although the drawings shown are for the Singer type long shuttle, all long shuttle machines with similar tension, check spring and take-up arm arrangements operate in much the same manner.

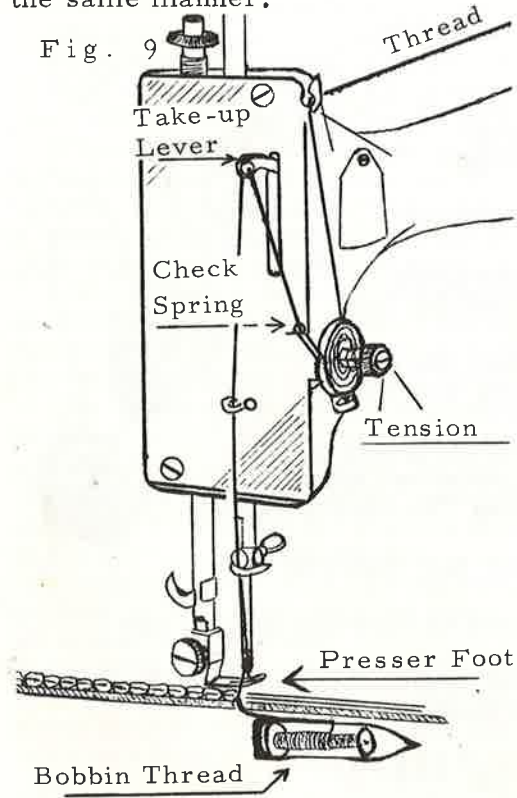

Fig. 9

Fig. 8

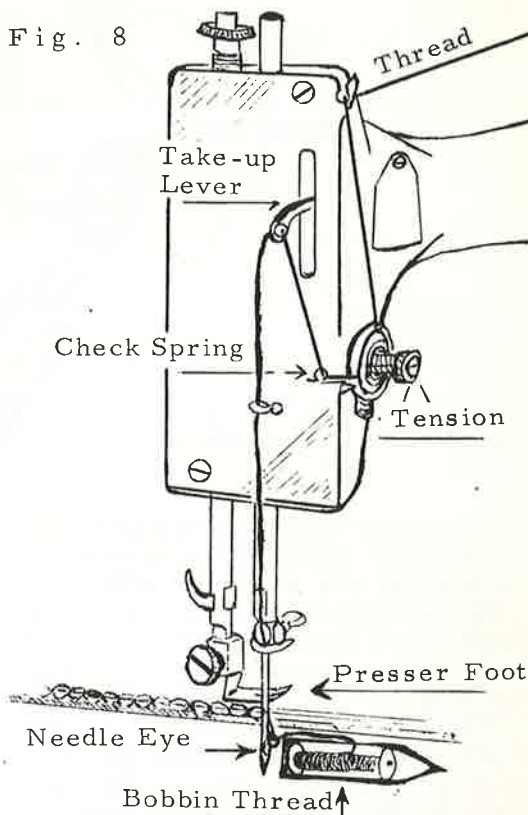

Figure 9. When the take-up lever reaches the highest point, the needle bar will be at its uppermost point and ready for the next descent.

The check spring holds the thread as shuttle returns to the rear of the race in preparation for the next stitch.

The stitch is pulled tight and knotted as the take-up arm, needle bar and check spring complete their work.

The feed dog has risen to its maximum throw, grips the cloth and pulls it ahead exactly the same distance each time in preparation for the needles descent and the beginning of the next stitch.

As the steps in stitch formation indicate, perfect seams occur only when each part functions in perfect coordination with the next part. Any malfunction will tend to affect the entire operation.

Therefore, when adjusting the sewing machine, always check entire system.

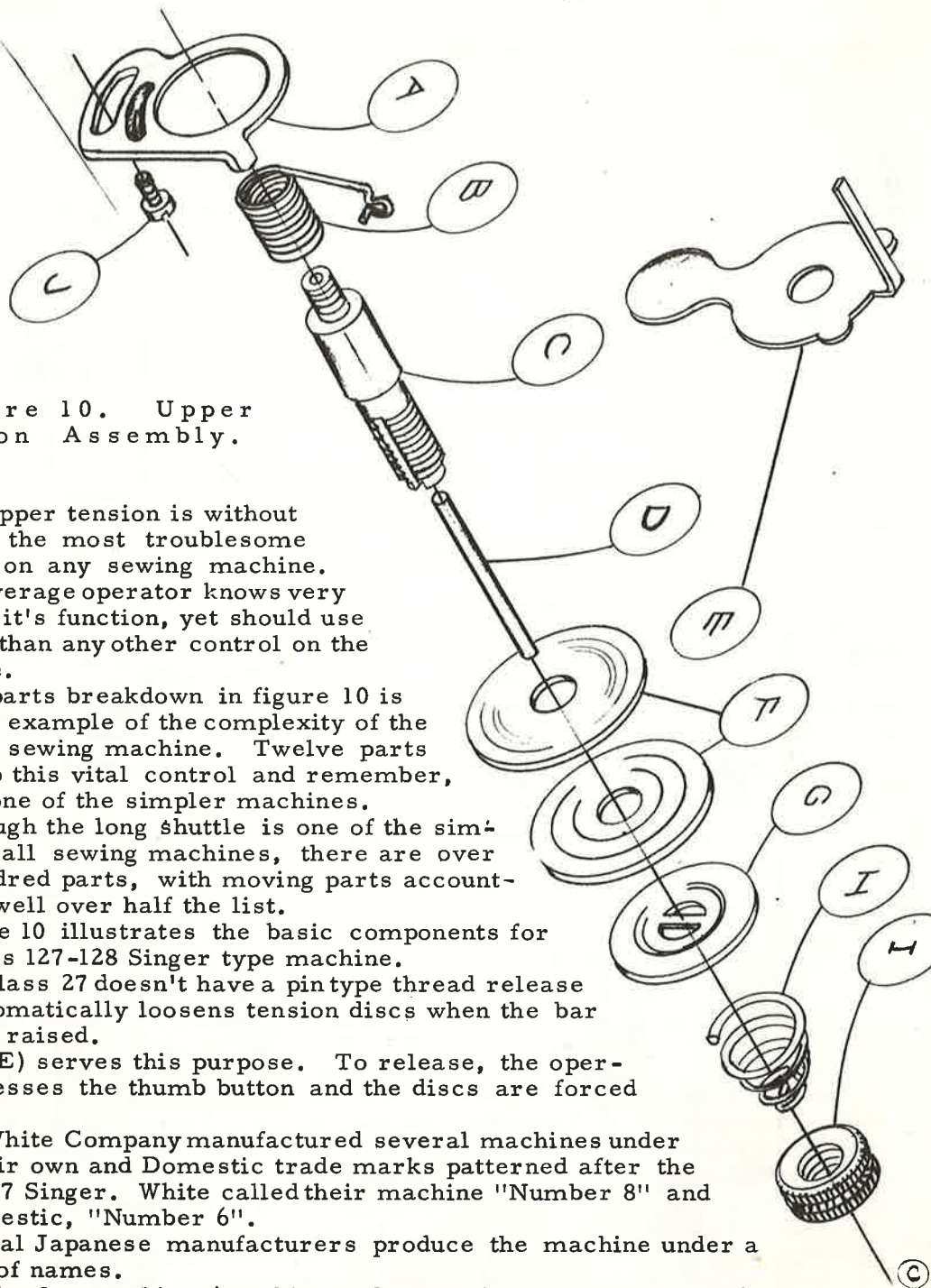

Figure 10. Upper Tension Assembly.

The upper tension is without a doubt the most troublesome control on any sewing machine.

The average operator knows very little of it's function, yet should use it more than any other control on the machine.

The parts breakdown in figure 10 is a prime example of the complexity of the average sewing machine. Twelve parts make up this vital control and remember, this is one of the simpler machines.

Although the long shuttle is one of the simplest of all sewing machines, there are over two hundred parts, with moving parts accounting for well over half the list.

Figure 10 illustrates the basic components for the Class 127-128 Singer type machine.

The Class 27 doesn't have a pintype thread release that automatically loosens tension discs when the bar lifter is raised.

Part(E) serves this purpose. To release, the operator presses the thumb button and the discs are forced apart.

The White Company manufactured several machines under both their own and Domestic trade marks patterned after the Class 127 Singer. White called their machine "Number 8" and the Domestic, "Number 6".

Several Japanese manufacturers produce the machine under a variety of names.

Most leader machines(machines advertised at very low prices) are long shuttle machines.

Basically, it is probably one of the most troublefree mechanisms on the American market and still enjoys wide usage.

Tension components are listed on page 15

Upper Tension Components (figure 10)

- A. Check spring adjustment bracket.
- B. Check Spring.
- C. Tension stud.
- D. Tension release pin.
- E. Thumb release (Class 27 only).
- F. Tension discs (2).
- G. Tension release washer.
- H. Tension spring.
- I. Adjusting nut (calibrated dial on newer models).
- J. Position screw for check spring bracket.

The Class 127 tension is a prime example of a typical upper tension regardless of make or manufacturer. The check spring bracket screws in place over the circular cutout in the machine head.

The tension stud screws in place with check spring fitting over the main body where it fits into the head. When the stud is tightened, the check spring is held firmly in place. On newer models, a set screw is located under the arm and when stud is screwed into place, the set screw will lock it securely.

Release pin (D) is inserted in the hollow stud (Class 127-128 only), followed by the tension discs with smooth side facing each other, the release washer, tension spring and adjusting nut (or numbered dial on later models).

When the upper thread has proper tension, it should flow through the tension discs with a constant drag, in direct relation to lower thread tension.

After the operator reaches the end of a seam, she lessens the upper thread tension so the thread doesn't break when she removes the material. The late models have a tension release built-in. Older model Class 27 machines use the thumb release described on page 14.

The presser bar lifter activates a release lever which pushes against the release pin (D) and moves release washer (G) away from the tension discs, allowing the thread to flow through.

When the presser bar is lowered with presser foot against the cloth, the pin is released and the tension discs assume the exact tension they had before, without any adjustment.

If tension adjustment is required, the adjustments should be in small gradations of a quarter turn on older nut type, one number at a time on numbered dial style tensions.

Refer to figures 15, 16 and 17 for proper steps in tension adjustment.

We are dealing in basics and the steps illustrated in this first chapter can form simple repair techniques for use on any sewing machine.

Remember, all lockstitch machines operate alike.



a
s) are
nisms on

After years of hard use and most long shuttle machines are of vintage variety, the threads on the tension stud will compress and the adjusting nut won't hold a setting.

To service, remove the tension assembly(see figure 11 below). After the components have been removed, place stud on a hardwood block or work-bench and spread stud(S) with a screwdriver(c).

Make the adjustment in easy stages. If too much pressure is applied, the stud will break.

Replace stud and components. Turn adjusting nut(13) to proper setting and test sew. If machine vibration continues to loosen setting, repeat procedure until corrected.

Figure 11

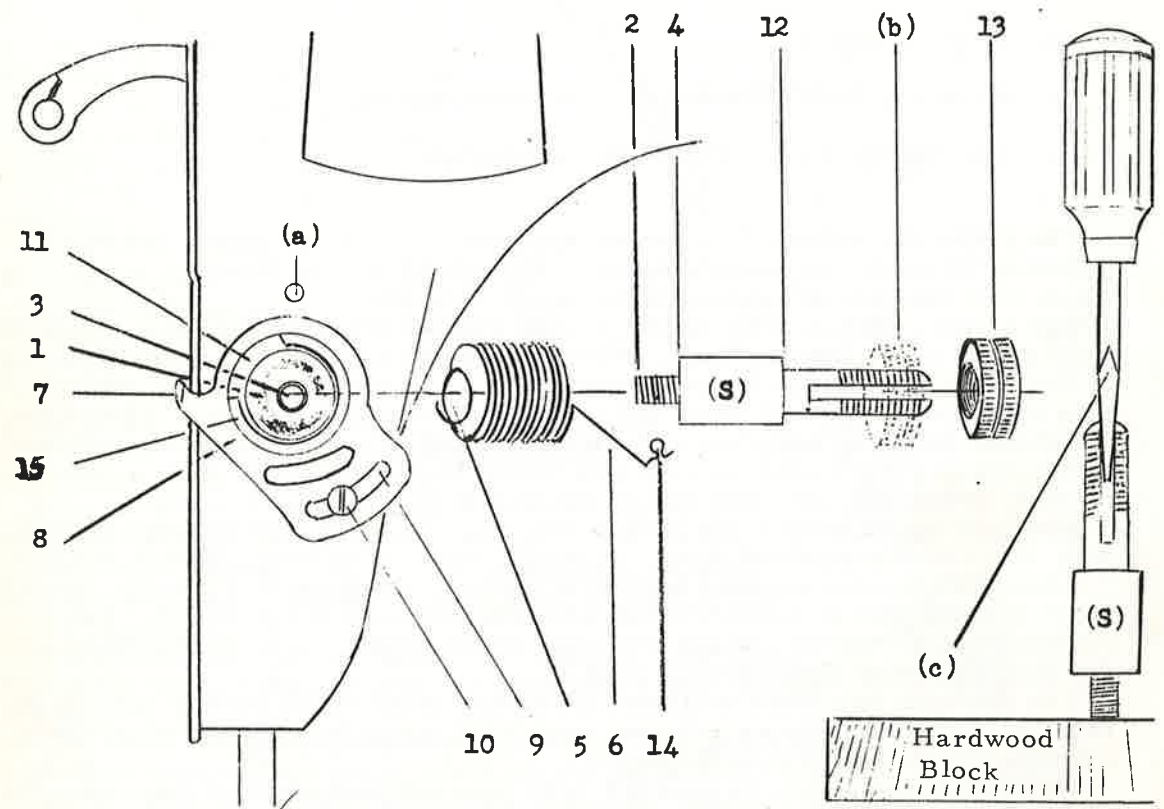

Check spring adjustment.

The check spring(5) is directly related to tension operation and adjustment. It helps the take-up arm control the thread, then releases the thread when the needle enters the cloth.

Ideal adjustment is present when spring drops to bracket stop(7) with some authority. To adjust, loosen screw(10) and move bracket(8) up. If opposite is true, reverse the adjustment.

Lower sewing and tension components

- A. Bobbin.
- B. Screw for attaching shuttle carrier to lower drive assembly.
- C. Shuttle carrier.
- D. Shuttle body.
- E. Shuttle tension spring.
- F. Adjusting screw.

Figure 12

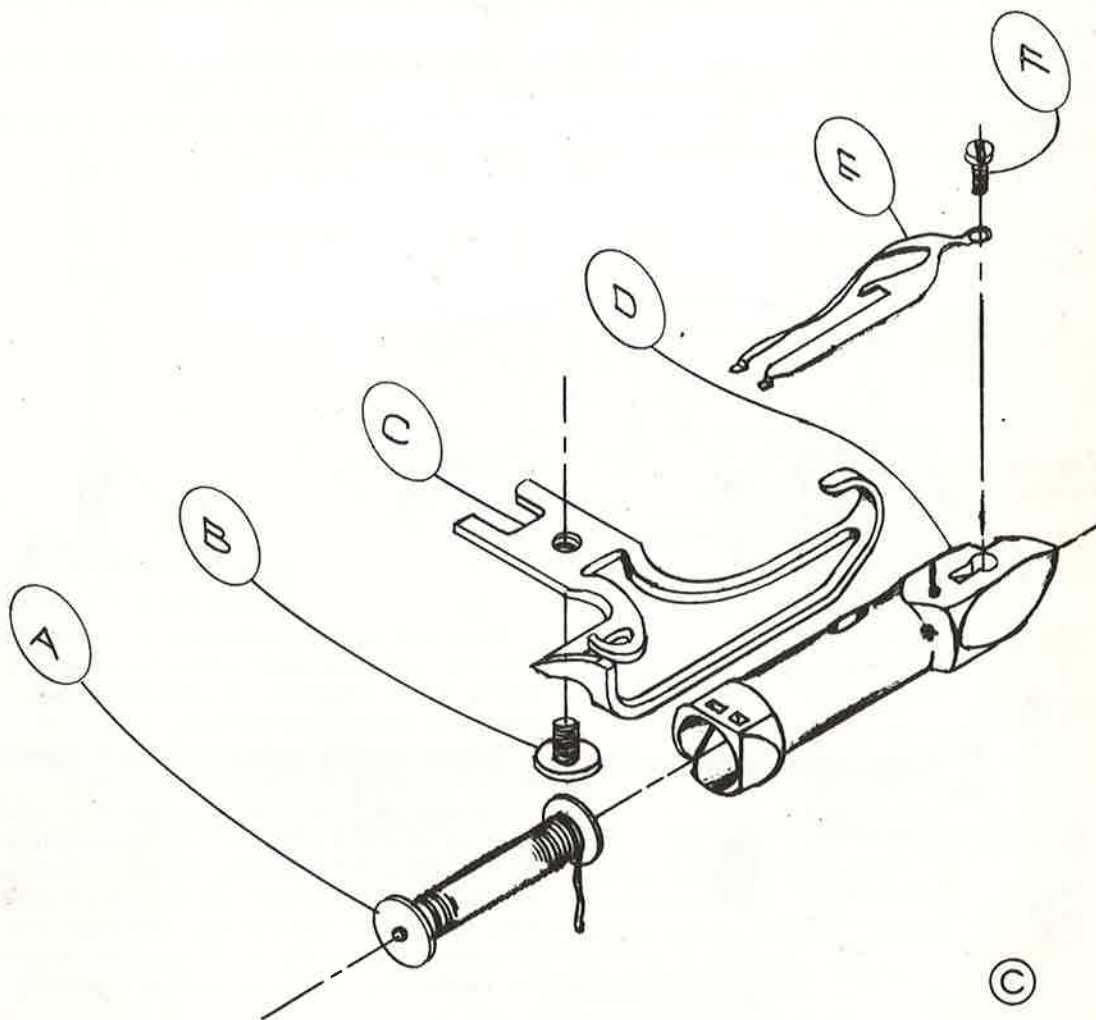

ntage var-
g nut won't

After the
k or work-

plied, the

setting and
t procedure

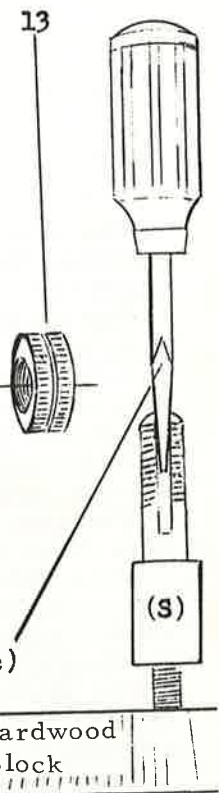

ardwood
lock

nd adjustment.
read when the

(7) with some
p. If opposite

Lower tension assembly

The properly wound bobbin is placed in the shuttle with the thread spinning off clockwise. The thread is pulled under the tension spring, leaving about 4 inches of thread hanging loose.

Before starting to sew, the operator pulls both threads to the top. See figure 4, page 11.

The lower tension is adjusted with screw(3), figure 13 below. For more lower tension turn screw clockwise, for less reverse the procedure. Complete tension adjustment is covered on the next three pages.

After years of use and wear, the adjusting screw will contract and not hold an adjustment.

To service, remove the screw and spread threads. Use a tension screwdriver for this adjustment. Exercise extreme caution while spreading the prongs to proper position. Replace and adjust as needed. Test sew and re-adjust tension if required.

The tension spring(6) should be checked periodically since years of use will thread cut a series of minute grooves in the metal. It's impossible to maintain constant tension with the part in this condition, therefore the part should be replaced.

Lint and dust build-up will produce the same effect. Always clean the area before attempting a lower tension setting.

In rare instances the shuttle may be thread cut. If this occurs, replace the shuttle. If shuttle contains any breakage, replace it.

Figure 13
Right

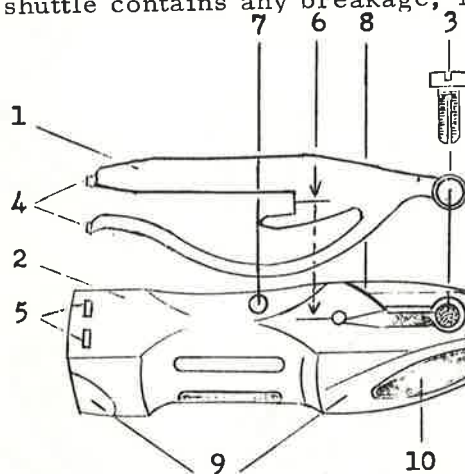
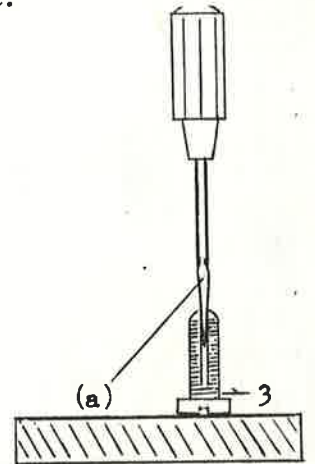
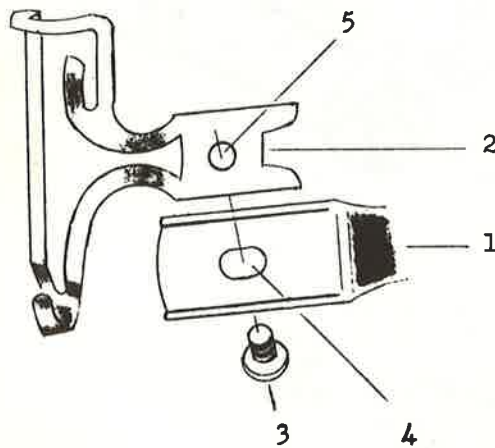

Figure 14
Below



Years of maladjustment between the shuttle and carrier often produces a badly worn shuttle. If shuttle is worn where it contacts raceway, replace it.

The carrier isn't so prone to wear and may outlast many shuttles.

Figure 14 illustrates method of adjusting shuttle carrier to compensate for wear in the shuttle. Loosen screw (3) and move carrier(2) toward raceway if shuttle too loose, the opposite direction if too tight. If carrier must be replaced, remove screw entirely.

Figure 15 illustrates irregular stitching with upper thread on the top of the material being sewn, as the lower thread is pulled completely through material.

Probable causes:

1. Upper tension too tight.
2. Lower tension too loose.
3. Check spring improperly set.

Correction:

1. Turn adjusting nut counterclockwise by quarter turns until threads are locked in center of material.
2. Tighten lower tension screw until corrected.
3. If above adjustments fail, adjust the check spring. Proper adjustment would place adjusting screw(10), figure 11, near center of slot(9) with adjustment bracket rest(7) near center of tension stud. If the spring is too weak, loosen set screw and turn entire stud assembly counterclockwise. If spring is too tight, reverse the procedure.
 - a. Check by lifting spring with thread and let it drop. The spring should drop sharply to the bracket rest.

Figure 15

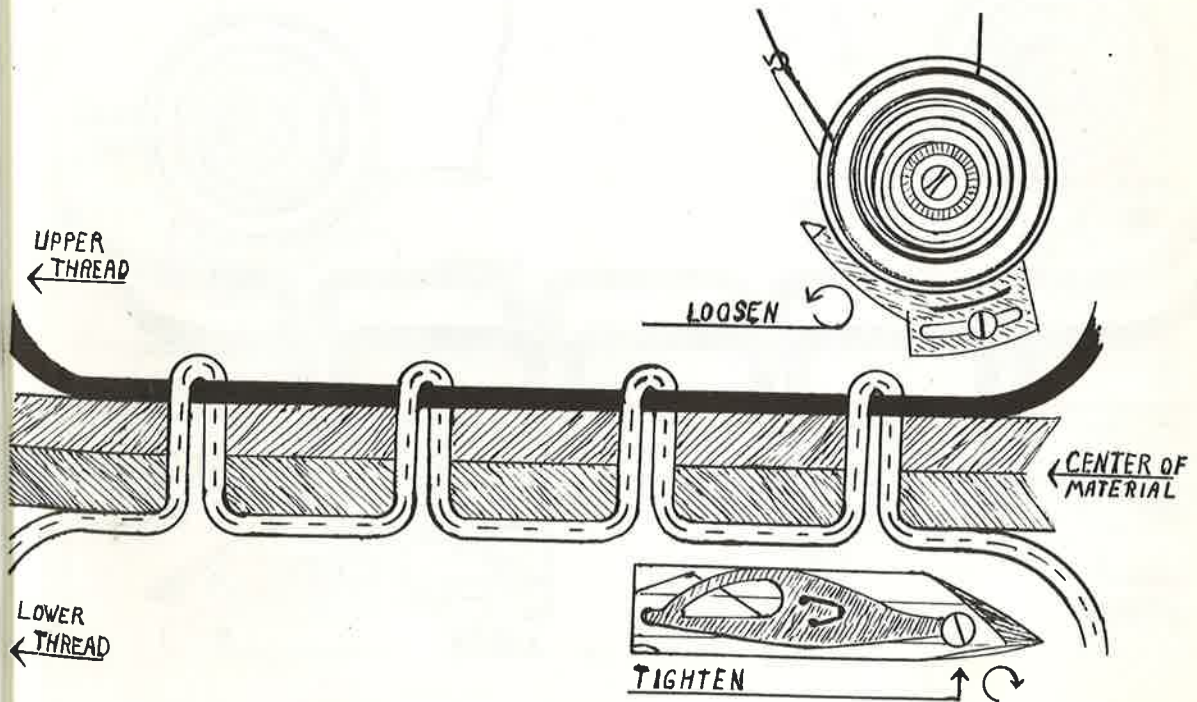

ad spinning
aving about

the top. See

For more
ure. Com-

and not hold

ision screw-
reading the
sew and re-

ears of use
ossible to
ore the part

ean the area

rs, replace

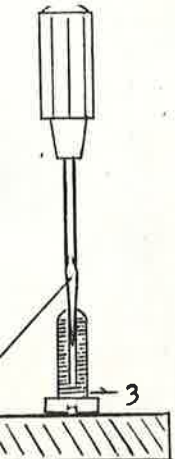

between the
produces a
ttle is worn
, replace it.
one to wear
ttles.

ethod of ad-
compensate
loosen screw
oward race-
the opposite
carrier must
ew entirely.

Figure 16 illustrates irregular stitching with upper thread being pulled thru with lower thread running along the bottom of the material.

Probable causes:

1. Upper tension too loose.
2. Lower tension too tight.

Correction:

1. Turn adjusting nut clockwise until threads lock in center of cloth.
2. Loosen lower tension adjustment until corrected.
3. Inspect shuttle for marris or cracks.
4. Check shuttle carrier and position of shuttle in carrier.
 - a. Remove both slide plates. Turn balance wheel slowly toward you and trace path of upper thread. When point of hang-up is found, replace the part, or if not damaged too badly, smooth with emery cloth.
 - b. If shuttle carrier is too tight, and forces shuttle against the race, loosen screw(3) figure 14 and move carrier until shuttle moves freely in raceway.

Figure 16

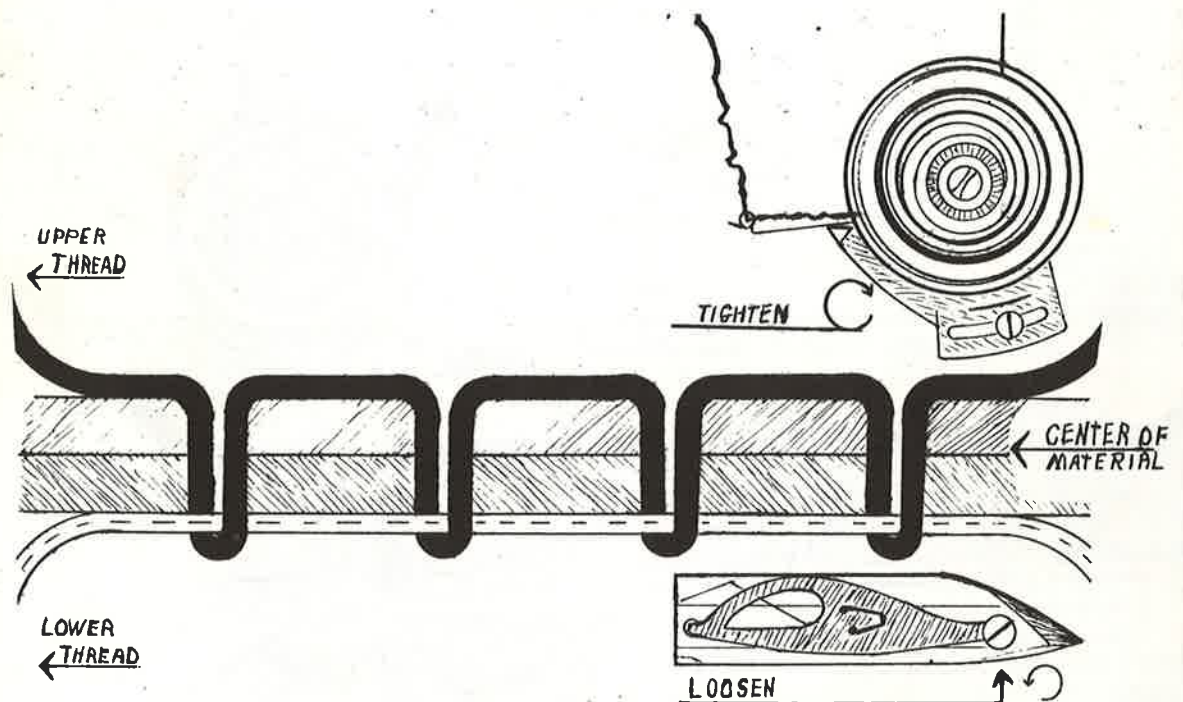

ng pulled thru

Figure 17 illustrates the formation of a perfect stitch. Both tensions are in adjustment and the machine is sewing at peak efficiency.

You will note the correlation not only between the two threads but the two pieces of material as well.

The threads are locking where the two pieces of material are joined.

In figures 15 and 16 the seam would unravel before the garment could be worn. The illustrations are extreme but varying degrees of either case would shorten the life of a garment.

Example: Check a few garments in your closet, in every case you'll find more expensive clothes have better looking seams.

To get a perfect stitch, the same weight thread should be used on the bobbin as on the spool. When repairing or adjusting a sewing machine, always insist on white thread and always sew on new, white fabric.

Colored thread on white material or vice versa will always create a wavy effect.

Always use proper needle for weight of thread used.

A complete needle and thread usage chart will be found at the beginning of the book.

Repair tip: Carry a spool of white 50 thread with you.

of cloth.

ly toward you
g-up is found,
th with emery

ainst the race,
shuttle moves

Figure 17

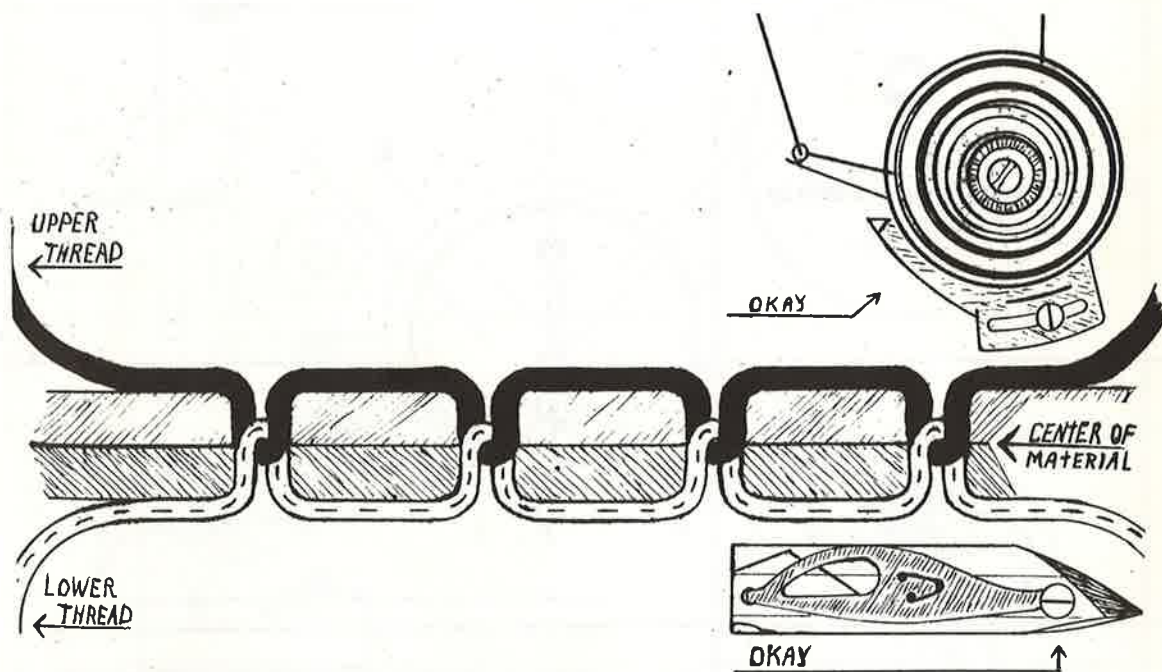

Figure 18. Covered Shuttle-Race Assembly.

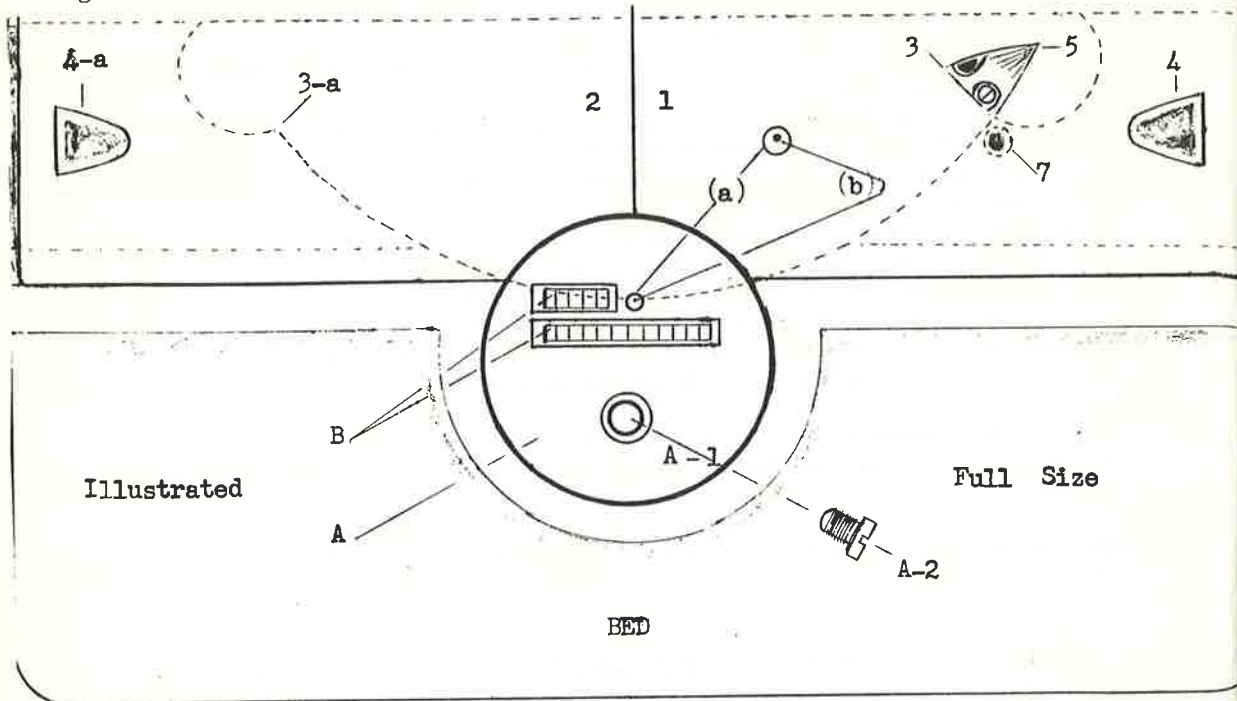

Figure 19. Shuttle-Race Assembly, exposed.

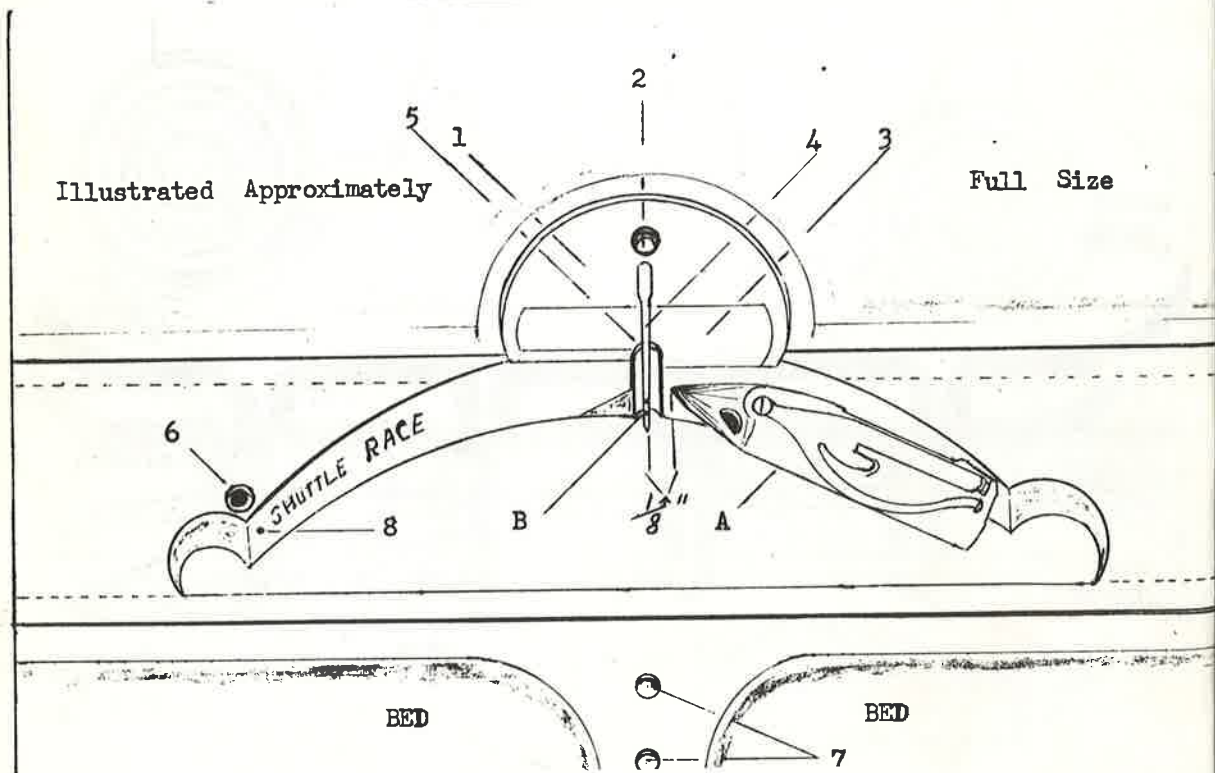
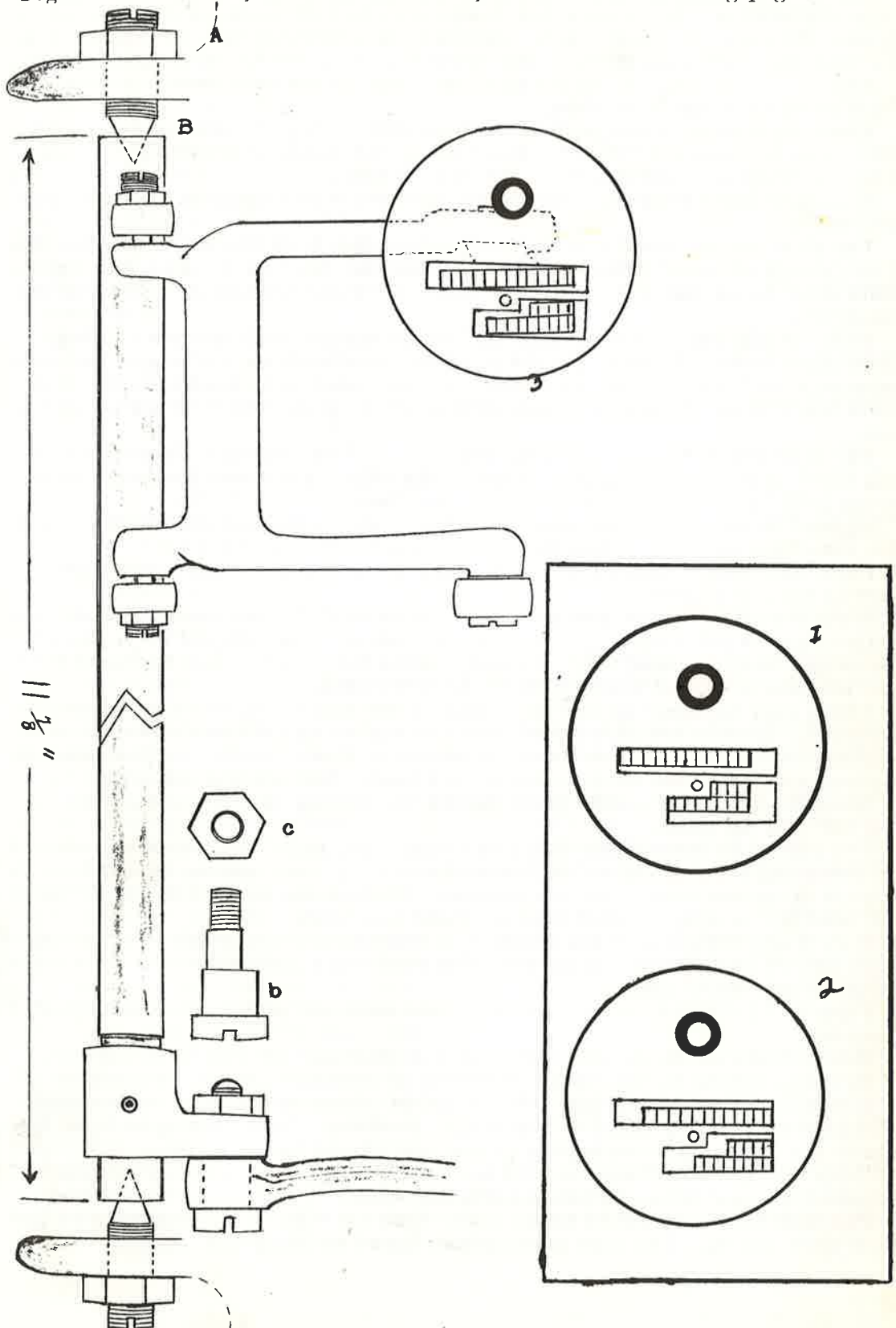

Figure 20 shows layout of lower feed system. Text following page.



The needle plate(A) figure 18 page 22, partially covers the feed dog and race assemblies. It serves a dual purpose in the sewing process. The needle passes through the needle hole enroute to it's meeting with the shuttle and, the feed dog teeth rise through the needle plate slots to feed the material.

After years of wear or excessive use, the needle hole becomes damaged from numerous needle strikes.

When the hole isn't too jagged, smooth with a length of emery cord. The plate may be removed from the machine by loosening screw(A-2). Use extreme caution to avoid enlarging the needle hole.

In case of severe damage the needle plate must be replaced. Follow same procedure.

The slots in the needle plate accomodate the feed dog(see B, figure 18). If the strips of metal between the slots become bent or broken, the needle plate must be replaced since it will cause irregular feeding or tearing of the material.

Worn or maladjusted feed dogs will cause erratic or improper feeding, to determine their condition tilt the machine head back on it's hinges and turn balance wheel toward you. Observe feed dog relation to needle plate. If the teeth don't show above upper level of the needle plate, the feed dog is set too low.

The feed dog is held in place by one screw. Turn balance wheel until feed dog rises to the highest point. Loosen the screw and move the part up until about $3/32$ " of the teeth appear above the plate.

Tighten the set screw and test sew. If repeated adjustments fail to remedy the situation, the part is too badly worn and must be replaced.

Feed dog adjustment is a rarity since most machines feed well until the part is beyond repair.

If the feed dog is replaced and the machine still doesn't feed properly, the roller cam or bell crank groove may be worn. They should be replaced if excessive wear is apparent. To test, move feed raising bar back and forth and observe action of roller cam in the bell crank.

There may be some up and down play in the bell crank itself. This can be adjusted. Loosen set screw and turn lock collar up until bell crank is snug. Tighten set screw and test sew. If machine binds, you've overadjusted it. Loosen set screw and back collar off $1/6$ turn. Tighten and test sew.

When feed dog hits needle plate during the sewing operation, the feed lifting bar may be loose.

The side play in the feed lifting bar(figure 20, page 23) can be eliminated by loosening lock nut(A) on each end of the bar, then turning tapered screw toward direction needed for correction. Tighten the tapered screw(B) until the feed bar is snug. Reset lock nuts and test sew.

Caution; Check feed dog position in relation to needle plate slots to make sure you've positioned it properly. The feed dog should rise and fall without striking the needle plate.

Figures 1, 2 and 3 on page 20 illustrate different positions of maladjusted feed dog.

Overadjustment to the left will result in situation present in position 1.

Overadjustment to the right will result in situation present in position 2.

Excessive wear or old age will result in situation present in position 3. When feed assembly reaches this stage, feed dog, feed raising bar and bell crank are probably worn beyond repair and should be replaced.

Very rarely must the main feed bar be replaced. Tapered screws may be adjusted several times to compensate for wear.

The feed fork is attached to the lower feed bar with an eccentric screw and lock nut(a and b). The feed assembly is timed at this point.

To time the feed assembly, set stitch control knob on extreme outer setting. Tilt machine head back and loosen lock nut(a). Turn balance wheel toward you and observe feed dog position in needle plate. Turn eccentric screw until feed dog rise and fall in exactly the same place. Hold eccentric screw firmly and tighten lock nut.

The feed fork is activated by a cam on the main shaft in the upper arm of the machine. (Refer to ghost drawing on page 8).

The stitch control is located near the center of the arm. On older models it's a knurled screw. The screw is grooved on the inner end. It moves in a cam and block arrangement which is riveted to the feed fork. As the screw is turned it moves the feed fork and changes the length of throw on the feed and changes the length of stitch.

When the control is tight against the head, the feed fork has more throw and long stitches are sewn. As the control is turned outward, the stitches become shorter.

Most late models are equipped with a back tack or reverse stitch control. The control generally works in a calibrated dial or slot with number of stitches per inch etched in the plate.

The reverse control is very advantageous to the operator since she may lock her seam without hand tying the threads.

The control is in the form of a lever and when it's moved up or down it changes the length of stitch. Midway on the calibrated slot is a median bar and when the control is moved over it, the machine sews in reverse.

The calibration runs from 6 to 32. The larger number indicates 32 stitches per inch and the smaller number 6 stitches per inch.

The new version is also a great asset to the operator since she can tell at a glance where the previous setting was and return to it.

The knurled screw is strictly guesswork and many hours have been wasted trying to return to an original setting.

The reverse lever is also used for darning and mending. The operator can move the lever back and forth in smooth, even cycles and produce a professional mend.

The lower sewing mechanism is activated by the rocker bar which moves back and forth on the main shaft. The rocker bar rides in the offset groove on the shaft. (See ghost, page 8).

As the machine turns the rocker arm moves one half turn, then back again. On the lower end of the machine, it's attached to the shuttle driving bar with a screw and lock nut. This in turn drives the bell crank assembly. The movement of this assembly moves the shuttle forward when the needle descends. Back when the needle ascends.

The needle is attached to the needle bar by the needle clamp. On this class machine, the needle always goes on with the flat shank in, toward the arm.

To service needle bar and balance of face plate assembly, the face plate must be removed. Loosen both screws and remove. (See figure 21, page 26).

The needle bar is held in place by a clamp-cam combination which rides a roller cam attached to the main shaft.

When the shaft turns, the needle bar moves downward in conjunction with the rocker arm which activates the shuttle driver.

The feed assembly remains in limbo until the sewing process has been completed. As the main shaft completes it's cycle, the feed cam comes into play and moves the material ahead for the next stitch.

Perfect timing is essential. The needle bar on Singer Class 127-128 is pinned and should never jump time unless the pin snaps.

To replace, merely line the hole of clamp with needle bar and insert pin screw. Tighten and test sew.

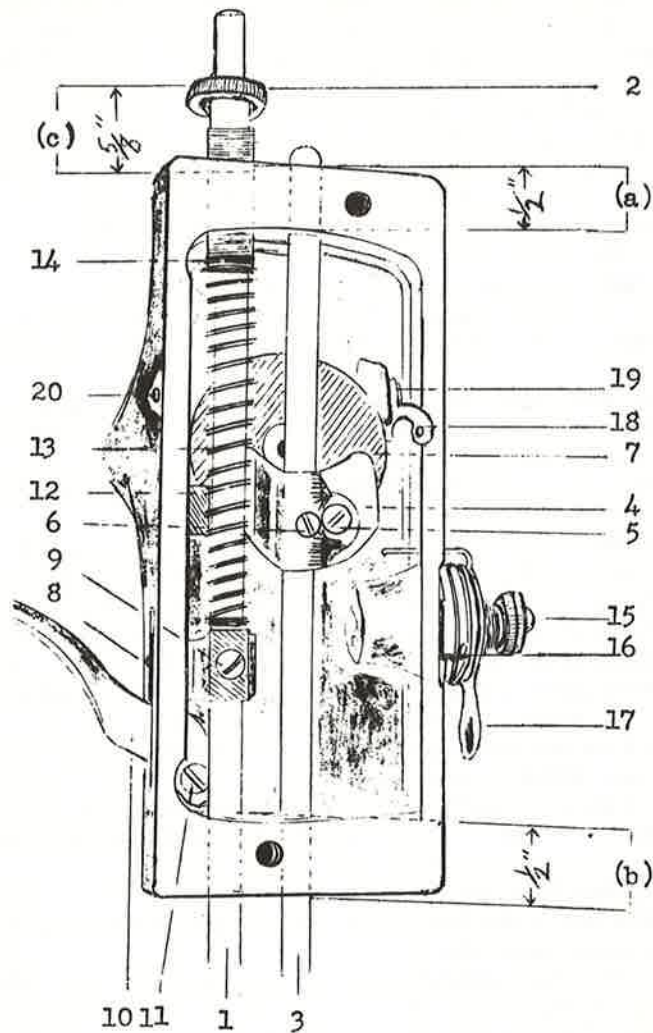

Figure 21

The presser bar assembly facilitates pressure and proper movement of the material from above.

The presser foot is attached to the lower end of the presser bar(1) with a thumb screw. Special sewing attachments such as the buttonholer, zipper foot and hemmers are also attached at this point.

Pressure is exerted by the spring(13) pressing against the lifter block(9). Adjustment for more or less pressure is controlled by knurled screw(2).

Regulation is generally required when machine is old and spring loses it's strength. For more pressure, turn screw down. For less, turn it up. The operator can change pressure for different weight cloth. Down for heavy material and up for light weight or synthetic cloth.

The presser bar lifter(10) is raised for removing or replacing material, lowered for full pressure when in operation.

The hand, or balance wheel, is located at the extreme right of the machine. It's primary function is locomotion, whether on a treadle, electric or hand crank machine.

Since it's located on the extreme end of the main shaft, it also serves as a balance in machine operation.

On treadle machines the leather drive belt fits in a slot on the inner part of the balance wheel.

Electrics feature either a belt drive, in the same groove, or a friction drive utilizing a rubber drive pulley.

Hand crank machines feature an elaborate gear set-up. The ratio is generally 2 to 1.

The clutch assembly is attached at extreme right of machine adjacent to the balance wheel.

At the point where the main shaft extends from machine arm, a slotted collar is attached. The balance wheel rides on the collar and the clutch is mounted next to the wheel.

This is the point where the machine is disengaged for bobbin winding.

The collar is notched and a clutch washer with three prongs fits over it. The washer fits against the balance wheel and the knurled clutch knob presses against it.

The control knob is pinned and screws into the end of main shaft collar. When the clutch is released, pressure from knob against clutch washer is released, allowing the balance wheel to turn freely. The pin strikes one of the washer prongs and stops knob from completely unscrewing.

When knob is tightened, the clutch presses against the balance wheel and the machine is re-engaged.

The bobbin winder (figure 22) is attached to the upper arm on older models and lower arm on later machines.

On the Class 27 machines the bobbin winder is activated by moving grooved wheel either against or under the treadle belt.

The later model Class 127-128 feature a rubber drive which is activated by pushing the winder directly against the balance wheel.

For good stitching the bobbin winder must be in proper adjustment. Earlier text explains what can happen with a badly wound bobbin.

The bobbin fits in place between the guide and spindle (See figure 22, page 28). Thread is inserted in guide (22) and wound manually around bobbin, two or three times.

Press rubber ring against balance wheel and observe the results.

If the bobbin does not wind evenly, turn balance wheel by hand and observe travel of winder guide. The guide should maintain contact with the heart cam at all times. When it doesn't, the spring is probably broken and should be replaced.

Remove screw (20), remove guide arm (8). Replace spring (19), guide arm and set screw. Test sew and observe.

If the guide arm jerks as bobbin is wound, check the worm or main gear. When the gears don't mesh, loosen screw on main and adjust.

Broken or bent gears should be replaced. Tighten all screws securely.

Worn bobbin winder rubber will cause erratic winding. Replace one each time you make a service call.

If user is servicing her own machine, the bobbin winder rubber should be replaced once a year if used frequently. Once every two years when machine is used occasionally.

The bobbin winder should be oiled frequently. Remember, a poorly wound bobbin makes a poor stitch.

Oiling a sewing machine properly is a must. Do it often.

The Bobbin Winder

1. Hood
2. Screw attaches hood to machine
3. Main bobbin winder body.
- 4, 5 and 6. Screw and nut attaches winder to hood.
- 7, 8, 9. Spindle, pulley and worm gear.
10. Bobbin winder rubber
- 11, 12 and 13. Spring and holder, holds bobbin in place.
14. Main gear.
15. Heart cam.
- 18, 19, 20, 21 and 22. Guide arm, spring and lock screw.

Figure 22

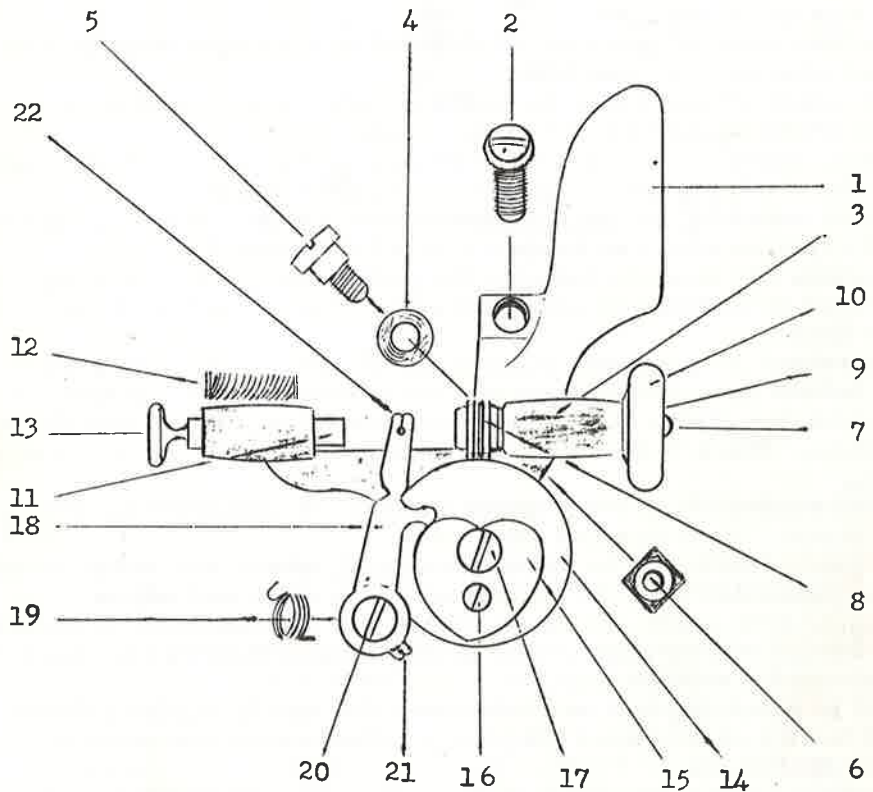

Chapter Two

Oscillating Hook Sewing Machine, Class 15

This chapter will light a flicker of recognition in thousands of sewing machine users. The Class 15 mechanism is no doubt the most popular type sewing machine ever manufactured. From the Singer 15-30, to Singer 15-91 series, or the HA-1 and contemporary models, both conventional, and streamlined, from various Japanese manufacturers.

New Home made a version, long before the merger with Free Sewing Machine Company, back in 1928. Many European makers have used the mechanism for straight stitch machines, as well as zig zag. Necchi, Anker Viking, Pfaff, Vigorelli, Minerva and Calanda all utilize a Class 15 type mechanism in various models.

Many early power machines were a beefed-up version of the 15-30. The 31-15 was an old workhorse for Singer, and many are still going strong.

A few machines manufactured in Japan and marketed in the United States, which utilize the Class 15 mechanism include, Atlas (defunct), Brother, Brewer, Classic, Morse, Nelco, Kenmore, New Home, Domestic (new series), Penncraft, Aldens, Spiegel, Fleetwood, Imperial, Modern Home, Premier, Remington, Riccar, Sewmor, Sincere, Signature (Wards, new series), Wizard, and White (since about 1953).

Obviously it would be impossible to cover all Class 15 machines in detail, but repair data in this chapter will apply to any machine, with Class 15, sewing mechanism.

Minor differences are easily discernable; slight changes in adjustment, shouldn't present a problem.

If you're the owner of a Japanese-made sewing machine, Class 15 variety, make yourself at home. This chapter is for you.

To identify your machine, tilt the head back and look at the lower sewing mechanism. If the shuttle-race assembly resembles figure 23, it's a Class 15, oscillator sewing machine.

Figure 23

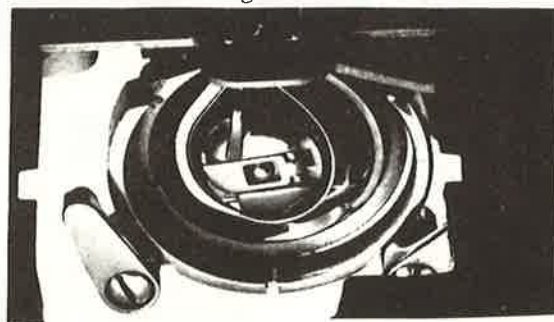

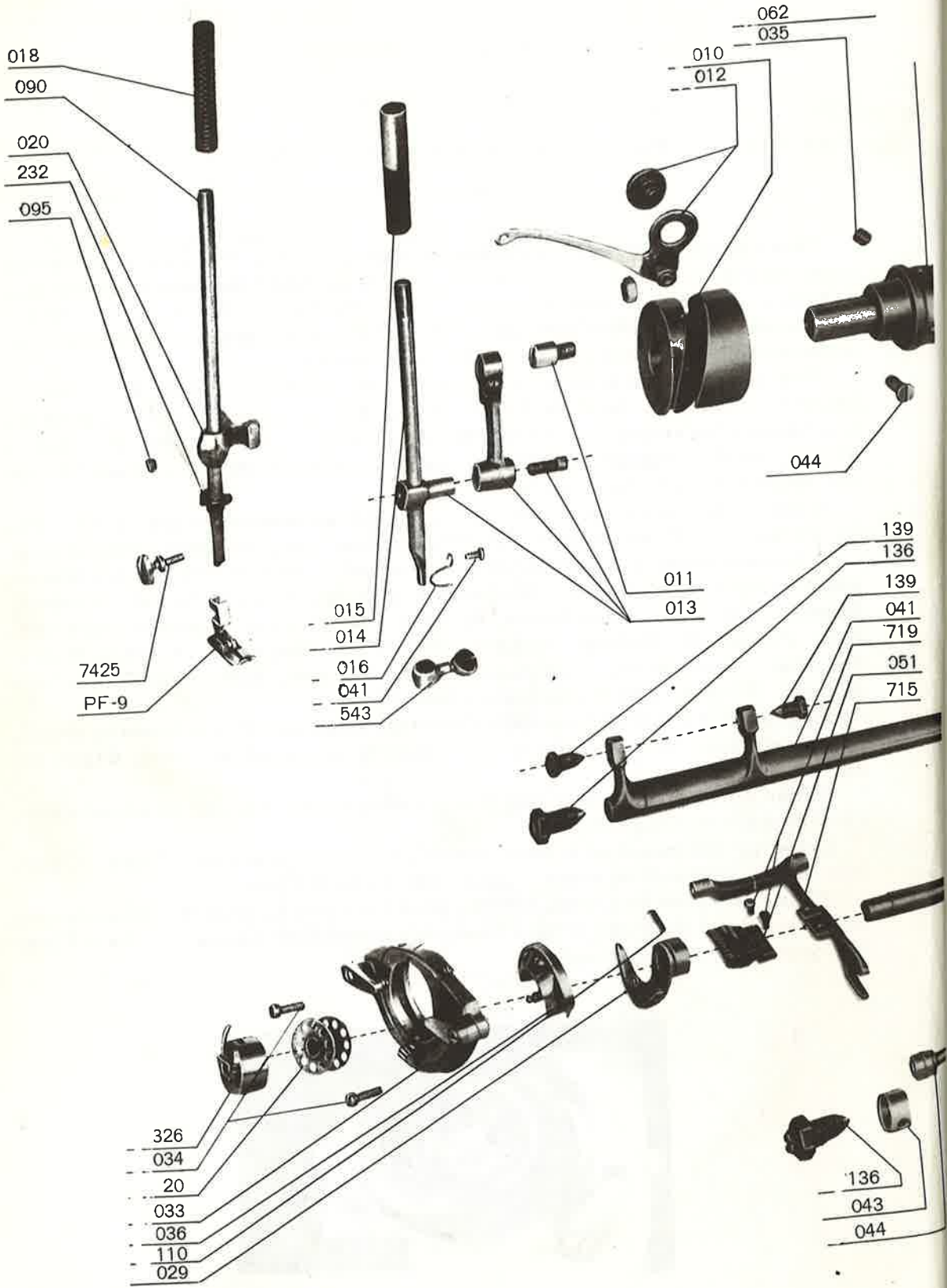

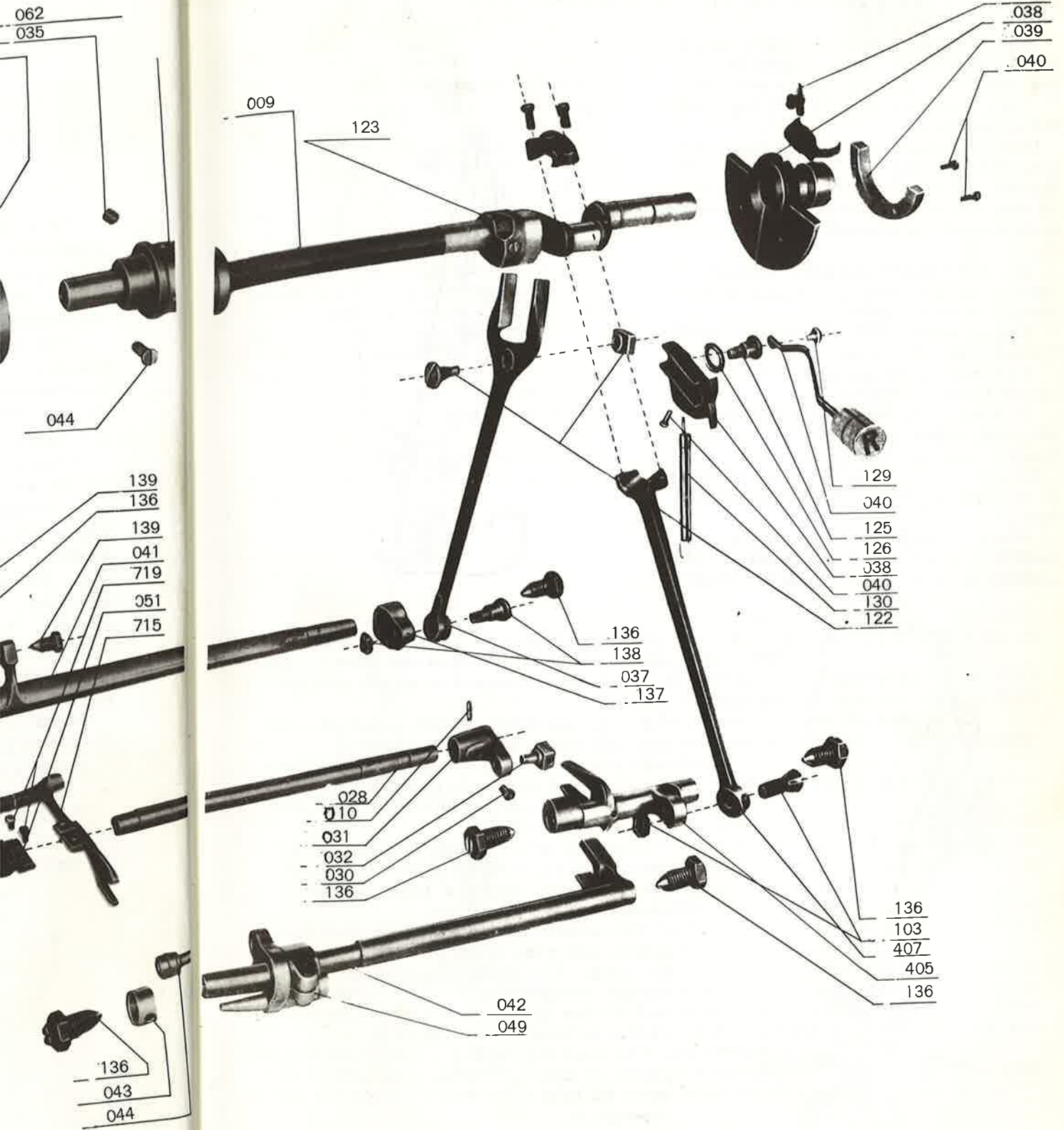

Operational pattern in stitch construction

Figure 25 illustrates proper way to thread the conventional Class 15 sewing machine with face plate tension.

This includes Singer and Japanese HA-1 machines.

Unwind thread from spool into guide (a), through the tension discs, over thread guard, into the check spring, up into the take-up arm, down through both thread guards and into the needle eye.

On older model Singer, thread the needle as illustrated. Imports also thread in this manner.

Singer models 15-88 through 15-91 thread from the opposite direction.

The needle is placed with the flat shank facing outward.

If user complains that machine is skipping stitches and she owns a 15-91 Singer, always check the needle first.

Singer 15-30 and all Japanese Class 15 machines thread the conventional way.

When in doubt, tilt machine head back and check hook position. Hook always passes needle on scarf side.

Figure 26



Fig. 25

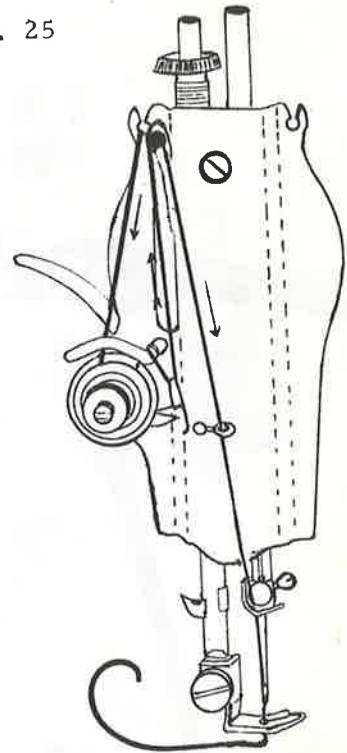

Pick up lower thread by holding top thread in the left hand and turning the balance wheel toward you until machine cycles.

Bring both threads back under presser foot and lower the presser bar.

As the machine turns the needle enters the cloth and descends toward the shuttle

The check spring releases the upper thread at the cloth.

Take-up arm lowers with needle and when both reach their lowest point, the slack thread forms a loop at right of needle eye.

The needle hesitates, then rises slightly, allowing point of shuttle to catch the loop. The shuttle carries the upper thread completely around bobbin case and circles lower thread which is wound on the bobbin, in bobbin case.

The feed dog remains inert during the phase of stitch making, since material must be held firm while needle travels through it.

The needle continues its upward motion.

Take-up arm remains down, giving the upper thread enough slack for it to encircle the hook and bobbin case.

At this point the thread is held in point of hook about half way around the circle. The oscillating hook moves in a half circle, then back again. (The machine class is named for this oscillating motion). When the point of hook arrives at its maximum position on bottom, it releases the upper thread, which in turn encircles the lower thread.

The hook starts back for the next stitch.

The feed dog remains inert.

The check is at rest on the thread guard.

Note respective positions of take-up arm, needle bar, check spring and hook.

Figure 28

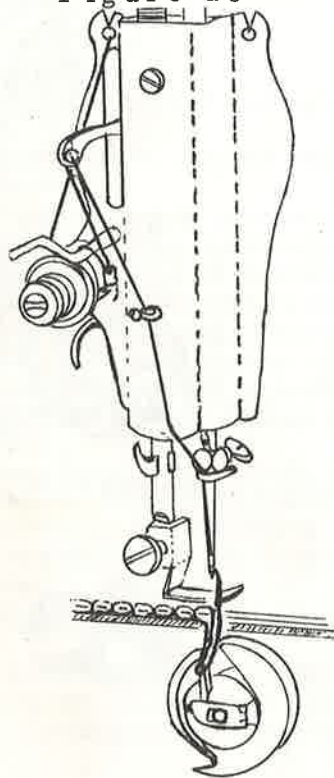
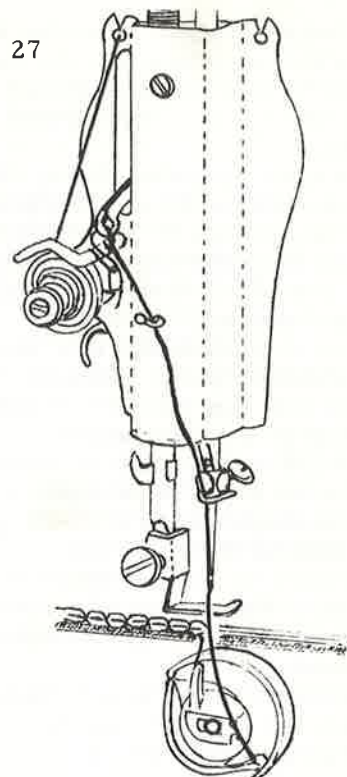

Fig. 27



The upper thread encircles bobbin thread and continues upward toward material.

The take-up arm starts to rise, pulling the slack thread and the loop out of the upper thread.

Needle is at its highest point as upper thread slides past the bobbin case and contacts lower thread.

The hook continues back to starting position.

Check spring remains at rest on the thread guard.

The feed dog has moved to a front position below the needle plate surface in preparation for rising and moving the material ahead.

The steps covered in this operation are basic and would apply to any oscillator type sewing machine.

Read it carefully, then follow each step on your sewing machine. Turn balance wheel by hand and watch each phase of the sewing operation as it unfolds before you.

Servicing your sewing machine will be much easier after you study it.

307098
 CANTERBURY
 PUBLIC LIBRARY

The take-up arm is at the highest point as it draws the upper thread taut.

Upper thread brings lower thread up and the lock is completed in the material.

When take-up arm rises, the taut thread activates the check spring and allows the thread to be pulled in straight line from the tension. The check spring assists in controlling slack in the upper thread.

The hook continues it's backward swing until the point comes to rest as it waits for the needles descent and beginning of the next stitch.

The feed dog starts to rise, then contacts the cloth from underside and moves it exact length according to the stitch control knob setting.

Pressure from the presser foot on top of material keeps it moving in a straight line, insuring the operator a good seam.

Thus the sewing cycle is completed and machine is ready for the next one or one thousand stitches.

Tension assembly

The Class 15 tension on the old type Singer 15-30 is similiar to the blowup of the Class 127.

The check spring and check spring regulator differ somewhat in design.

New style Class 15 machines have calibrated dial tensions. (figure 30).

Streamline versions with the link take-up and front tension, feature a unitized, barrel assembly. (figure 31)

Tension assembly (figure 32), is a numbered dial (not calibrated) and it must be reset for different stitches.

Figure 32



Figure 29

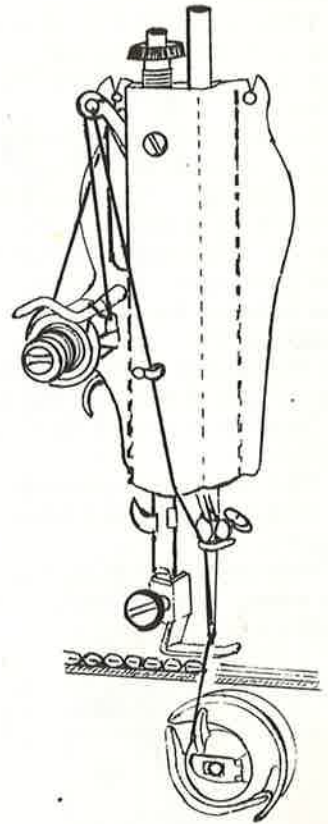

Figure 30



Figure 31



Upper Tension

To remove tension assembly on conventional Class 15, loosen set screw in rear of holding block and pull the assembly toward you.

Note: There are two screws at this location. The screw in curved slot is for adjusting check spring.

Remove knurled adjustment knob and other components from tension stud. Place all components in the order they are removed from tension stud.

Inspect both tension discs for thread cuts. Thread cut tension discs must be replaced. Positive tension control can't be attained with thread cut discs.

If user complains that tension doesn't release when presser foot is raised check the release pin. When the pin is bent or worn, replace it.

Recheck before removing assembly, making sure the pin is tight against holding block so the presser bar lifter can contact it.

On models with calibrated dial and positive tension control, inspect the tension spring retaining washer. If washer finger is broken, replace it.

After years of hard use, the tension stud becomes depressed where adjustment knob is located. This is apparent when user complains that the machine will not hold tension adjustment. When the stud prongs are depressed, machine vibration gradually loosens the setting.

Refer to Chapter one, page 16. Use extreme caution in spreading stud. Overadjustment may result in a broken stud. Replace adjusting nut and test sew.

To re-assemble tension, reverse above procedure. Be sure tension is pressed tightly against the holding block.

Lower presser foot before tightening set screw. Raise presser bar and check tension release.

Check Spring

Bent or broken check spring should be replaced when tension assembly is removed.

To adjust throw, loosen set screw in slot on holding block and move adjusting barrel.

The check spring is properly adjusted when it releases the upper thread as the needle enters material on the downstroke.

When check spring is overadjusted, the thread is held too long. Not enough spring, the opposite is true.

Check proper spring "tension", by threading the machine, past tension and spring. Pull spring up with thread and let it drop. If it falls sharply to the rest, adjustment is probably close enough.

If it flutters down, loosen set screw and turn adjusting block downward about $3/32$ ".

If it jams hard, reverse the adjustment about $3/32$ ".

Caution: Since each machine is set differently, the check spring could vary somewhat, but the above figure would be close.

When the check spring drops with some authority, it's probably close to perfection.

High speed machines require a little more accuracy.

To remove tension assembly on Class 15 with the link take-up, open face plate door, or loosen plate screws if plate is attached. Loosen set screw in cast, directly opposite the tension and remove.

29

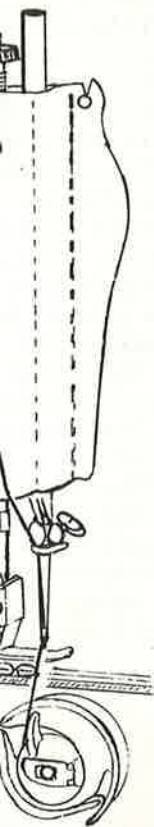

e 30



e 31



Follow the same steps for adjusting this style tension. The basic components are alike.

If the check spring is broken or bent, it must be replaced.

To remove, loosen set screw on tension barrel and remove the tension stud. Remove check spring from stud.

When replacing, place spring over tension stud with small finger of spring in groove on stud. Screw tension stud in barrel (if screw type) or insert in hole and tighten the set screw.

Test check spring for proper tension.

If the check spring has too little tension, loosen screw and turn tension stud counterclockwise until corrected. Tighten screw, replace tension barrel in machine head and test sew.

If check spring has too much tension, reverse the procedure.

Lower Sewing Mechanism

The 15 class shuttle-race assembly differs slightly from machine to machine, but except for the Singer 15-88 to 15-91 series, the components will generally interchange.

Figure 33 illustrates the difference between the Singer 15-88 thru 91 series and the older Singer 15-30 and all the imported machines manufactured, using the 15-30 as a basic pattern. The bobbin case is illustrated below.

Bobbin case (A) is used in the 15-30 and most imported 15 class machines. Bobbin case (B) is from the Singer 15-88 thru 15-91 series.

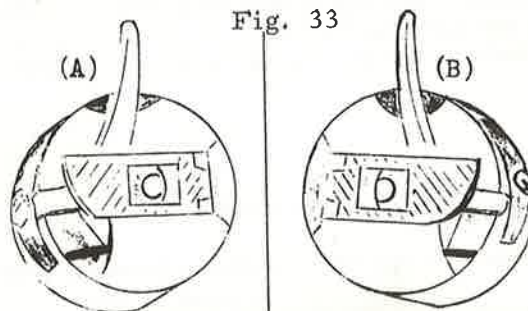

Fig. 33

Figure 34 illustrates the difference in shuttles. Shuttle (A) is from the 15-30 and import series. Shuttle (B) is from the 15-88 thru 15-91 series.

The difference between the two shuttles is that the older style picks up the thread on the outer side of the needle and the newer style just the opposite. This is the reason for placing needle differently. See page 32.

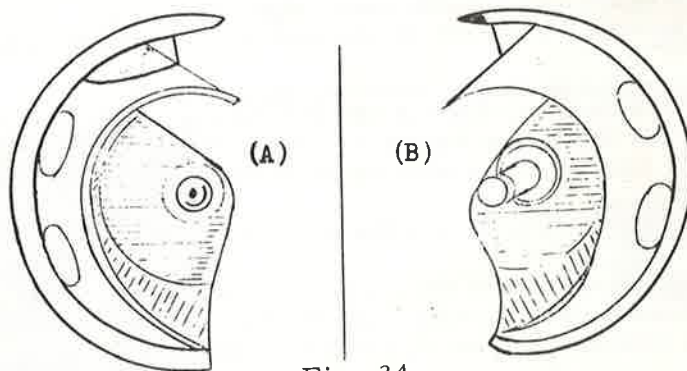

Fig. 34

The Bobbin Case

Proper knowledge of the bobbin case is essential for good sewing machine adjustment.

The lower tension plays a direct role in maintaining a good stitch.

The most important step is threading the bobbin case correctly.

Step A shows bobbin entering the case with thread coming off counterclockwise.

Step B shows slot (1) where thread enters tension spring.

Adjustment screw(3) controls lower thread tension.

Step C shows correct bobbin case threading with thread under spring and extending out the notch.

The finger(3) goes up, where it fits into notch on race cover.

Figure 36 illustrates complete component breakdown of bobbin case.

Main body(1), spring and screw (2 and 3), latch spring and screw(4, 5, 6 and 7). The lower tension is adjusted by turning screw(3) against spring(2).

Clockwise tightens the tension counterclockwise loosens it.

If repeated adjustments fail to effect tension, the spring is probably badly thread cut and should be replaced. (thread cut is series of grooves worn in the tension spring by thread).

The adjustment screw is very minute and adjustment range is small. Don't force the screw or you'll ruin the bobbin case.

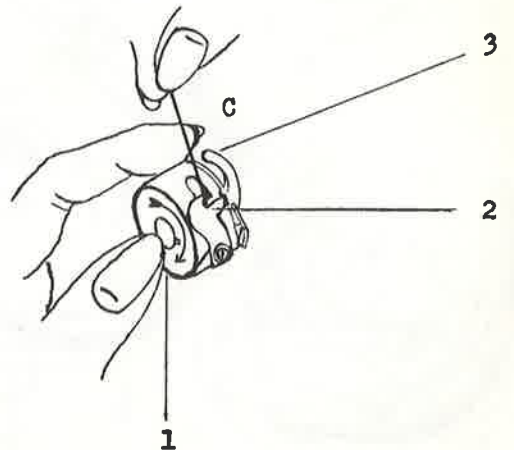
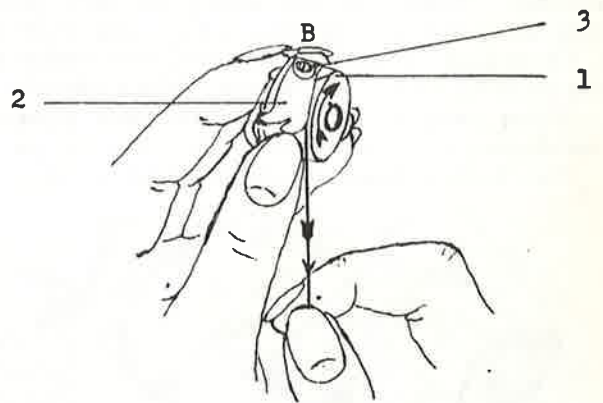
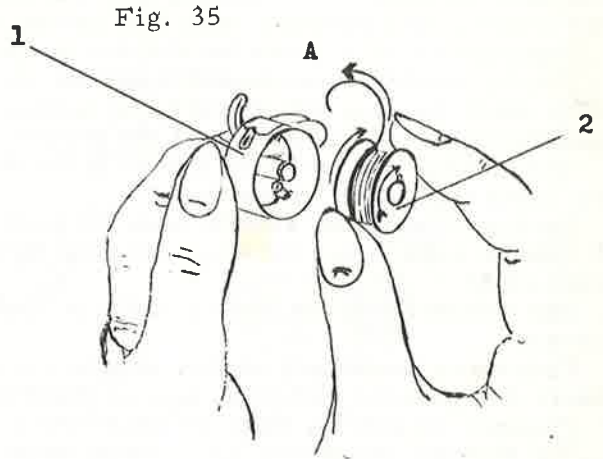
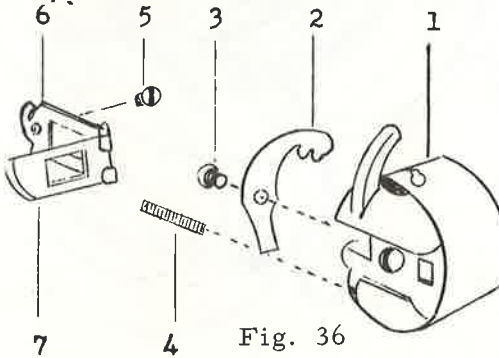

The 15 class hook is shaped like a half-moon. It fits over the shuttle driver into the race. It's held in place by the race cover. Figure 37 illustrates the relationship between each component of the lower sewing mechanism.

Dimensions shown are for the conventional 15 class.

Driver shaft(6) is activated from the upper main shaft by a connecting link with slide bearing which works in conjunction with the slide block (11). The shaft(6) is timed and pinned at the factory, in block(8) with tapered pin (3).

The shuttle driver(2) is pinned to the driver shaft with pin(3a). The race encloses the entire assembly.

Spring (4) aids the shuttle hook (3) as a stabilizer during stitch formation. A typical race cover (1) fits over pins in race(7) and locks in place with two latches(8).

The bobbin case fits over spindle in hook with finger up and in slot of race cover.

There are variations of this assembly, but all machines contain the same basic components and fit in sewing machine the same way.

Figures 38 and 39, page 39 illustrate a few different race assemblies.

To service the assembly, check each component. Shuttle, bobbin case, race cover and shuttle driver.

If user complains of constant thread breakage, check the shuttle driver spring. Years of use will generally result in a broken spring. The thread will snag since it passes the spring on every stitch.

To repair, loosen screws(5) and remove the spring. When you replace it, the curved end of the spring faces shuttle point.

When severe needle strikes are apparent, smooth with emery paper. If the damage is too severe, replace the part.

For bobbin case service, refer to page 37.

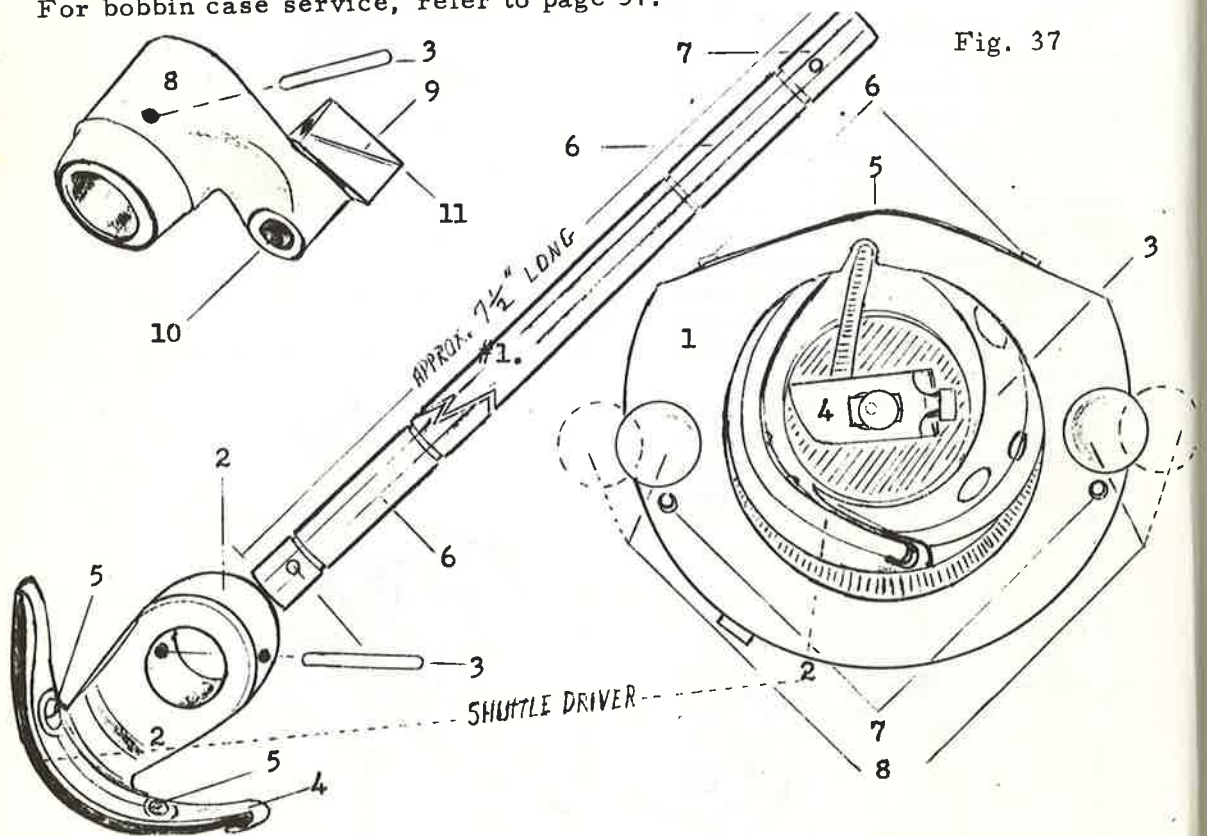
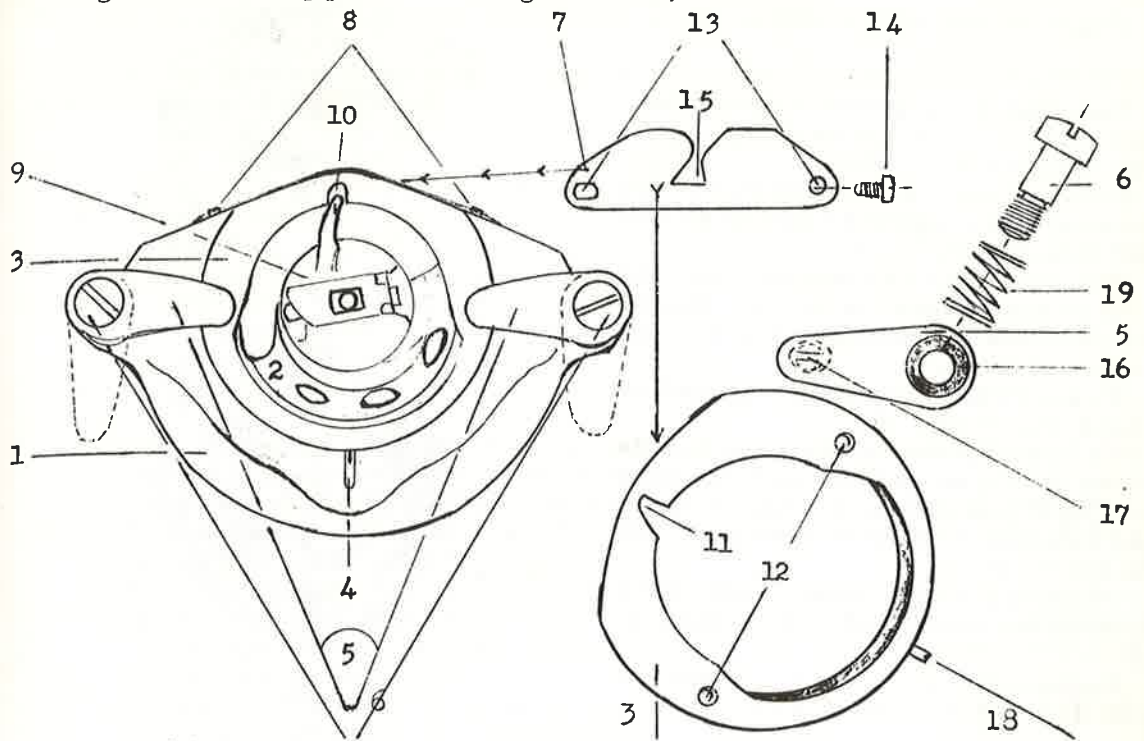

Fig. 37

Figure 38, upper.

Figure 39, lower



ttle dri-
llustrates
anism.
cting link
(11). The
d pin (3).
The race
formation,
with two
ot of race
the same
bilities.
bbin case,
ttle driver
The thread
replace it,
paper. If

Fig. 37

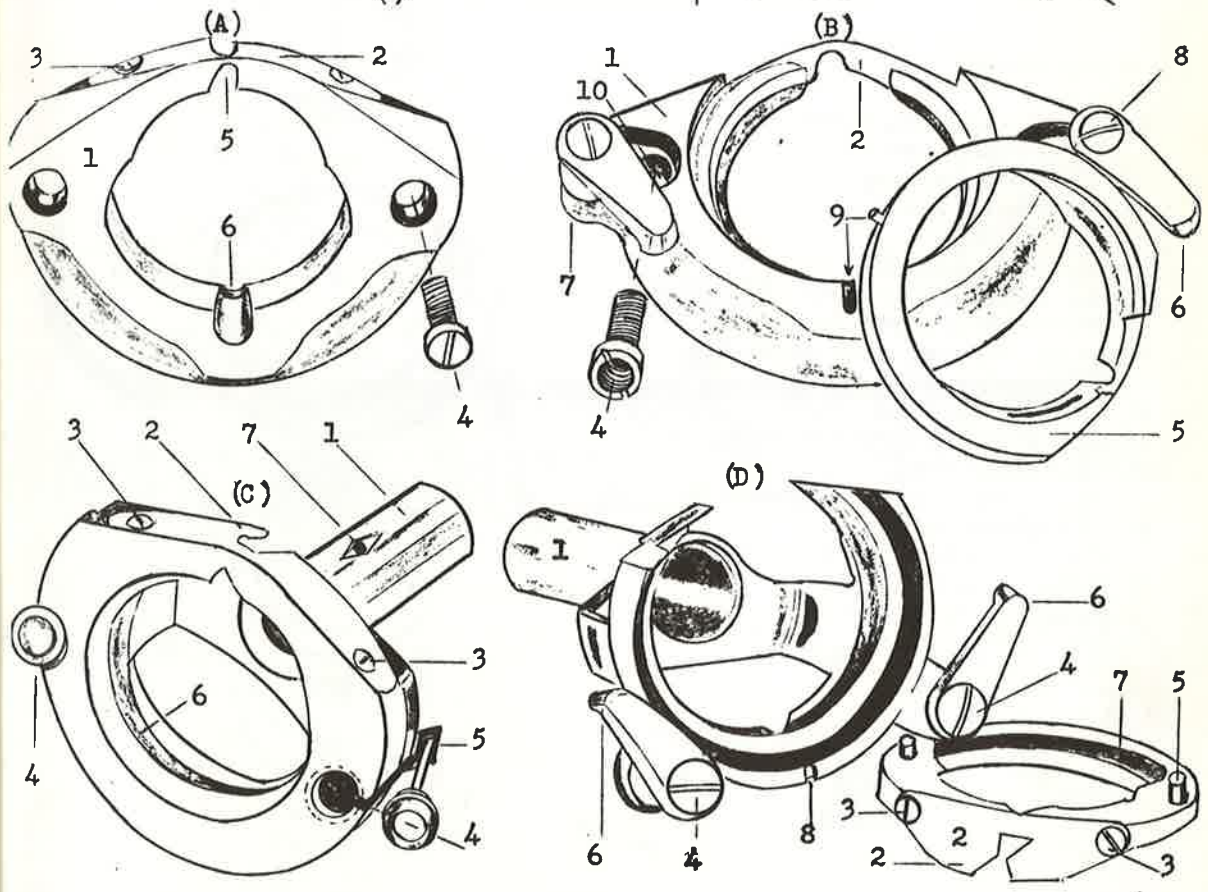
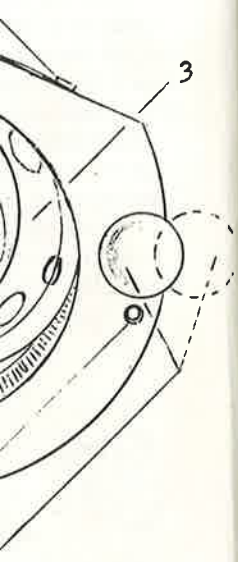

Figure 40 opposite.

To remove, loosen both screws(6), and screw(11), which holds spring F and retainer E in place.

Remove race cover and shuttle by twisting them upward slightly as you pull toward you.

The shuttle(C) is inserted from the rear of race cover, or exactly opposite previous instruction and diagrams in this chapter.

To service, follow steps outlined on pages 36, 37 and 38.

To reassemble, make sure shuttle rides freely in the race and fits over shuttle driver properly before replacing retainer, retainer spring and the thumb screw.

Position the race cover and turn the holding screws(6) and tighten securely.

Replace the bobbin case, thread the machine and test sew.

Components

- A. Race assembly complete.
 - 1. Race cover
 - 2. Cover spring
 - 3. Cover screws
 - 4. Shuttle
 - 5. Bobbin Case.
 - 6. Retainer screws
 - 7. Thumb screw hole.
- B. Rear view of race assembly.
- C. Rear view of shuttle.
- D. Rear view race cover.
- 8. Pins for retainer ring.
- E. Retainer ring.
- 9. Holes for pins number 8.
- F. Retainer spring.
- 10. Hole for thumb screw.
- G. Thumb screw.
- 11. Screw should be snug-tight.

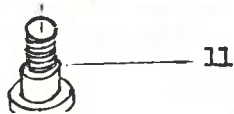
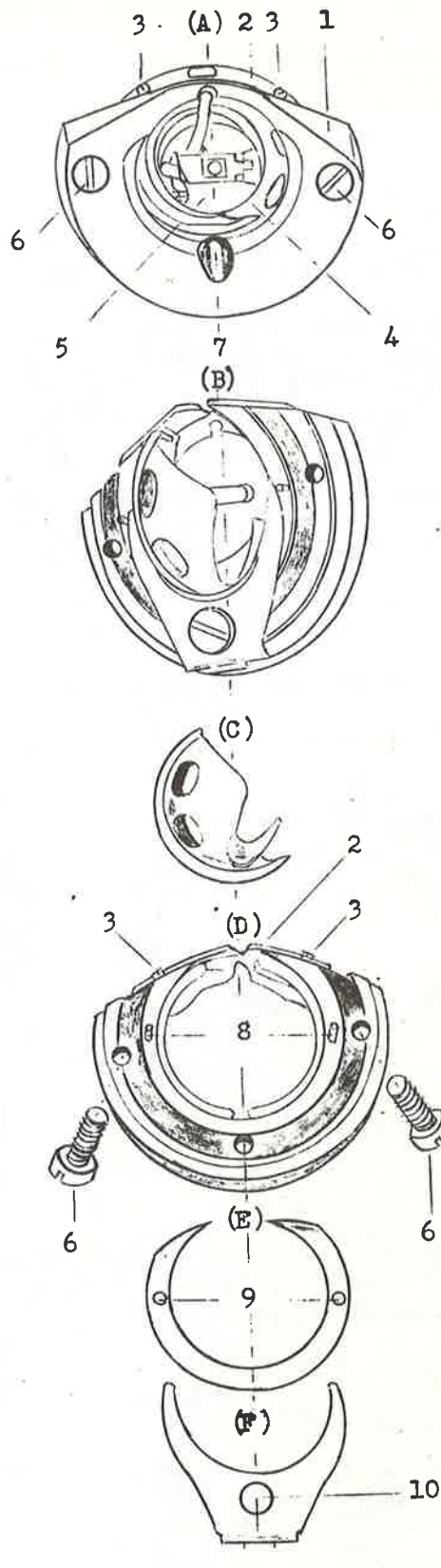

Simple guide to proper tension adjustment.

Figure 41 illustrates improper stitch with top thread running along on top of material as lower thread is pulled through completely.

Probable cause:

1. Upper tension too tight.
2. Lower tension too loose.
3. Check spring incorrectly set.
4. Bobbin case spring is thread cut.
5. Adjustment screw stripped out.

Correction:

1. Turn adjusting nut or numbered dial counterclockwise, either 1/8 of a turn or one number at a time on dial until corrected.
2. Remove bobbin case. Use a tension screwdriver, adjust clockwise.
3. Check spring should release thread as needle enters material. Refer to page 35 for check spring correction.
4. If tension screw adjustment doesn't change tension, replace spring.
5. Inspect the spring as you tighten the tension screw, if it isn't depressed against the bobbin case, the adjustment screw is probably stripped and should be replaced.

Caution:: Due to small size of screw, extreme caution must be exercised in handling and adjusting it.

Figure 41

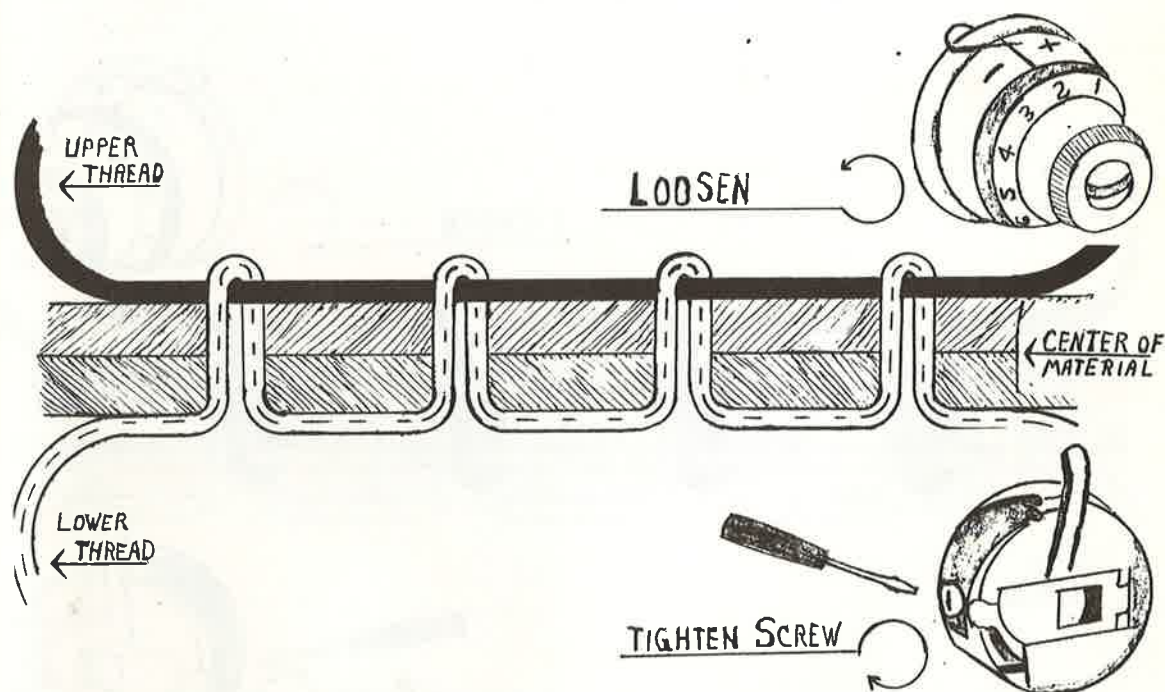

Figure 42 illustrates a sample stitch where the situation is reversed. The upper thread is being pulled through material by stronger lower thread or a maladjustment somewhere in the lower sewing mechanism.

Probable cause:

1. Upper tension too loose.
2. Lower tension too tight.
3. Bobbin case incorrectly inserted.
4. Burr on hook.
5. Driver spring broken or bent.
6. Bits of thread or lint in shuttle race.

Correction:

1. Turn adjusting nut, or numbered dial, clockwise about 1/8 turn or a number at a time until corrected.
2. Remove bobbin case and loosen tension screw until corrected.
3. Hold bobbin case latch between thumb and forefinger. Insert on hook spindle until it clicks, then release the latch. If it doesn't latch, check hook spindle for thread or lint in groove. If latch is broken, it should be replaced.
4. If hook is broken or burred near point, replace it.
5. When replacing the hook, if the shuttle spring presses too tightly against it, replace the spring. If the spring is broken, replace it.
6. The shuttle race assembly should be cleaned and oiled on every service call. If user is doing own service, do it once a month.

Figure 42

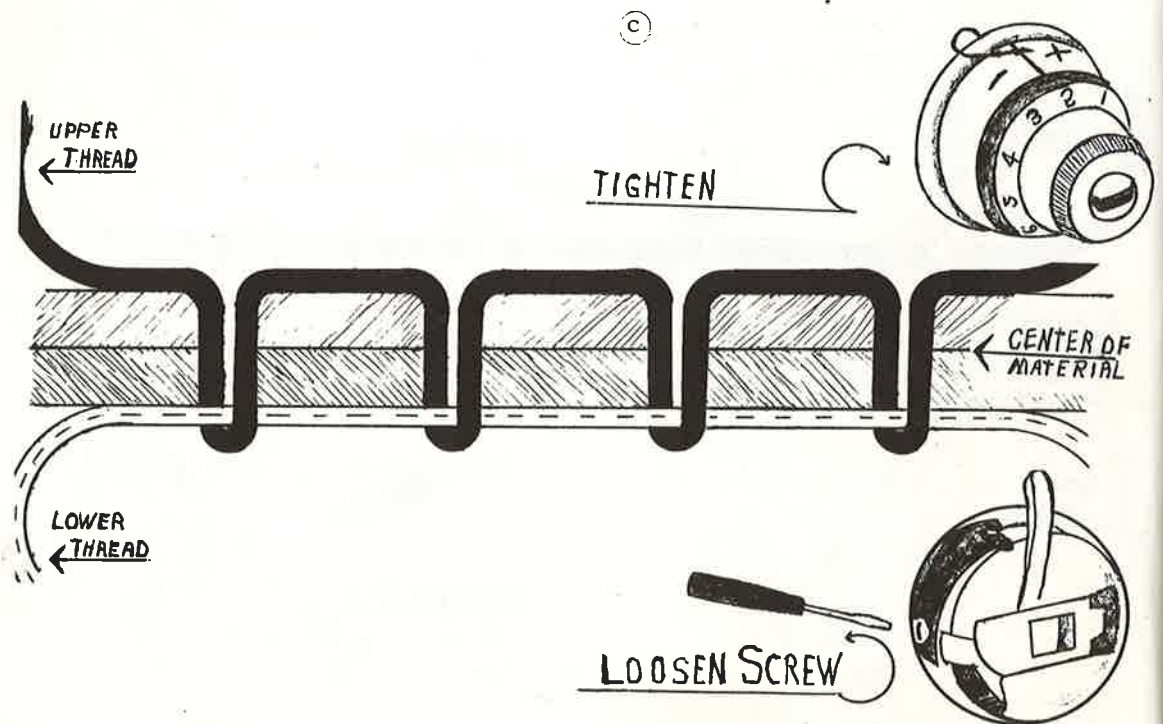

Figure 43 illustrates a perfect stitch. Both threads are locking in the center at junction of both pieces of material being sewn.

The perfect stitch is readily discernable as lock in cloth is equally placed from top or bottom and stitch is equal in length as it stretches across cloth in an even, straight line.

The user often forgets a few basic truths which go into the make-up of a good seam.

1. Always use same size thread on bobbin as on upper thread. Same color too!!!
2. Never use a small needle with heavy thread or vice versa. The old wives thinking that heavy thread makes a stronger seam is simply not true, unless it's used on heavy fabric.
3. Always use standard size thread, generally 50, and proper needle, number 14, for regular sewing.
4. Proper stitch length must be used in direct relation to size and type material being sewn.

If user remembers these simple facts, she'll save herself a lot of grief.

The introduction of this book contains a chart which lists needle sizes and proper thread to use with each.

Figure 43

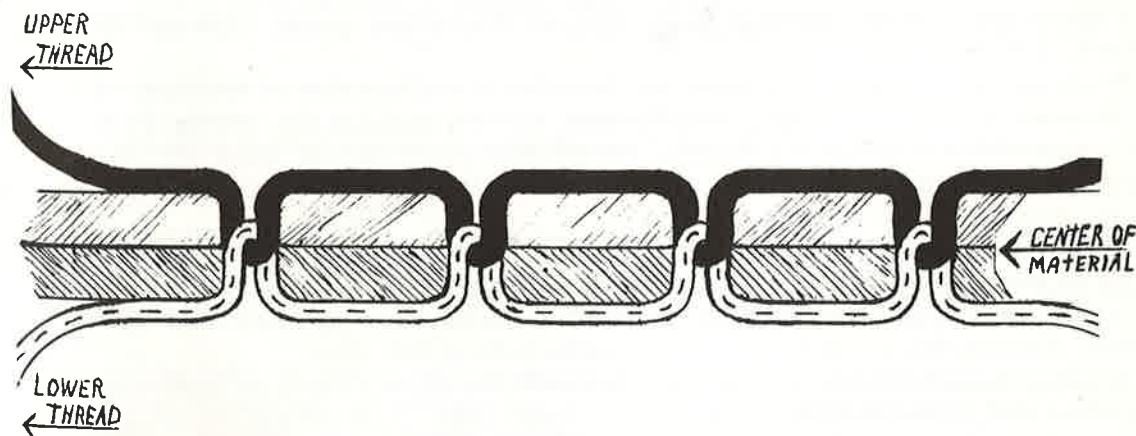

sed. The
read or a

turn or a

ced.
rt on hook
sn't latch,
broken, it

tightly ag-
ace it.
every ser-
n.



The Needle Bar

The needle bar on the conventional Class 15 sewing machine is activated by a connecting link, attached to a stud that is threaded into the main shaft cam. The schematic on pages 30 and 31, illustrates the relation of the cam to the needle bar, and the components which must be removed to dismantle it. Screw(013 assembly) is accessible through a hole cut in casting under the machine arm. When it is loosened, turn counterclockwise, allowing a needle bar to be removed, or timed, whichever is necessary.

The Class 15 head can be timed at the needle bar with a very simple adjustment.

Turn balance wheel until take-up arm is at highest point of travel. Move balance wheel toward you, until set screw(013 assembly) is visible through the access hole.

Loosen and remove both screws, then remove the needle plate.

Loosen set screw(013 assembly, page 30.)

Lower needle bar manually, while turning balance wheel toward you, until shuttle point approaches the needle.

As the shuttle point approaches, set the needle about $3/32$ " above the eye to the point of the shuttle, on the needle bar upstroke. See figure 44.

Figure 44



Tighten set screw(assembly 013), replace the needle plate, tighten both screws, and test sew.

When timing a sewing machine, or checking a malfunction of tension, or in the area concerning sewing mechanism, always replace the needle first. When a machine is properly timed, the shuttle point should ease into the needle scarf, immediately after the needle reaches its lowest point, hesitates, and starts the upward stroke.

Most late model Class 15 machines, including Japanese, have a timing mark on the needle bar. To time a machine with the timing mark, remove the face plate, turn balance wheel toward you until the set screw(013) is visible through the access hole on the underside of the arm.

Loosen the screw and move needle bar until the timing mark is flush with the lower end of the needle bar bushing in head cast. Tighten set screw and replace front face plate.

CAUTION: When adjusting the needle bar, always hold it firmly in line so it won't twist to one side or the other. The slightest turn will cause the machine to skip stitches. Check alignment before tightening the set screw.

Before timing the needle bar, check the needle clamp and stop screw.

Many times the stop screw will break off and when the needle is inserted in the clamp, it will slide up too far causing the machine to skip stitches or not pick up the lower thread at all.

Needle bar - Class 15 with link take-up system.

The short needle bar arrangement is similiar to that covered in chapter 3 on the Class 66. Refer to chapter 3 for adjustment procedure.

Take-up arm.

The take-up arm on the conventional Class 15 is located at the back of the arm.

A roller runs in the main cam and the retaining screw is accessible through a hole in the casting.

Negligence in oiling or maintaining the machine will cause the roller to wear.

Machines with worn take-up arms generally rattle with a rhythmic clack clack sound.

To replace, remove the face plate.

Loosen set screw through hole in casting and remove take-up arm through front.

If you replace the take-up arm, replace screw at the same time.

The take-up arm travels on a shoulder of the screw. They are mated at the factory so if old screw is to be used, adjust the collar to fit new part.

If machine binds after this part has been replaced, remove screw and arm and work arm back and forth until bind disappears.

To test take-up arm for wear, hold balance wheel tightly in right hand.

Move take-up arm with left hand. If excess play is present, it's wise to replace the part.

On rare occasions the roller will freeze, generally from lack of oil.

Loosen set screw and remove the part.

Soak part in can of solvent overnight. Move roller back and forth until it's loose enough to roll freely. Clean thoroughly, oil and replace.

Replace face assembly and test sew.

If machine binds, refer to previous text on shoulder screw and arm.

Link take-up arm.

The link take-up arm is similiar to Class 66, chapter 3. Refer to it for service.

Presser bar.

The presser bar holds the presser foot and guides the material in a straight line, working in direct relation to the feed dog as it moves the cloth ahead.

- It's held in place by an adjusting block which serves two-fold purpose.

First it acts as the vehicle for lifting when the presser bar lifter is activated. Second, it holds the adjusting spring in place.

A set screw holds the lifter block to the bar. At this point the correct height between presser foot and needle plate is determined. The most common measurement is 1/4" clearance when feed dog is lowered.

To adjust, release pressure adjustment screw (or activate patchomatic if machine is so equipped), raise presser bar and loosen set screw.

Adjust presser bar to proper height.

Tighten set screw, reset adjusting screw and test sew.

Before making final adjustment, check the adjusting spring. After years of wear the spring has a tendency to lose strength. Stretch it manually and if it still appears weak, replace it.

When replacing the adjusting screw on a stretched spring, turn down two or three times more than normal.

For sewing heavy material, turn screw down two turns more than normal position.

For lighter or synthetic fabric, reverse the procedure and turn adjusting screw out two turns.

On machines with automatic darning, depress or release adjusting button as needed.

Most older Singer machines will have adjusting screw. Most imports will have automatic darning attachment.

The presser foot is held in place on lower end of presser bar with a thumb screw. Most thumb screws are slotted and may be tightened with a screwdriver. Do so wherever possible.

Later machines come equipped with a walking foot (hinged for walking over pins and heavy seams).

If you're servicing a machine without a hinged foot, suggest it to user for better sewing and performance.

Sewing attachments are attached to presser bar with a thumb screw.

Before using a buttonholer or other heavy attachment, check all set screws on the presser bar assembly. Tighten and make sure presser bar is properly aligned.

Buttonholers exert great pressure on the sewing machine. Machine should be in top condition before using any attachment.

Check presser bar lifter. After years of use, the set screw may loosen or embossed ridge for releasing tension may wear.

If user complains that tension doesn't release when she raises the presser bar, check the lifter.

If part is badly worn, replace it.

Always check the presser foot for wear, especially on older machines. Most users have a habit of sewing off the material. When this occurs, the feed dog grinds into presser foot and wears a groove. In latter stages, this will cause erratic feeding.

Caution: When adjusting the set screw on presser bar, always hold bar so the presser foot lines up with needle hole and feed dog. Hold firmly while tightening all set screws.

The feed system.

The feed system is activated when the feed fork (037) turns on eccentric cam (123) on the main shaft. See pages 30 and 31. It's attached to the lower feed bar (041) with an eccentric screw and nut.

On the middle, upper end of the feed fork, a slide block and adjustment lever is attached. The length of stitch is controlled at this point, although the part may vary slightly from machine to machine.

A knurled screw controls the stitch on older Singers. When the screw is adjusted inward, the block has more throw and the machine sews a longer stitch. When the screw is turned outward, the block has less throw and a shorter stitch is the result.

On later models with a reverse, when the lever is pulled over center, or depressed if reverse button, the block moves over center, changes throw of feed fork in opposite direction and the machine sews in reverse.

The lower feed bar(041) is held in place by two tapered screws with lock nuts.

If the feed bar is loose, loosen both lock nuts. Turn tapered screws inward until the bar is snug.

Caution: Do not over-adjust or machine will bind.

Check feed dog in relation to needle plate. When dog is centered in slots and doesn't strike the plate, tighten lock nuts and test sew.

Use the same adjustment on feed lifter bar(715), with screws(139).

The feed dog screws in place on the feed lifter bar. To adjust, service or replace the feed dog, the needle plate must be removed.

Raise the presser bar, loosen needle plate screws and lift plate upward.

When plate has been removed, feed dog is accessible for repair. See figure 45 below.

Caution: When tightening feed dog screws, snug tighten, then replace needle plate.

Set machine on long stitch, turn balance wheel toward you two or three times. Feed dog must not strike plate at any point. When you've determined feed dog is properly adjusted, remove needle plate, tighten set screws, replace needle plate and test sew.

Figure 45

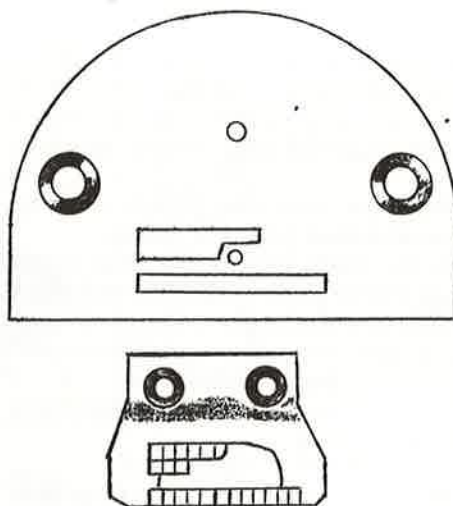

The feed raising bar works off the driver slide block(405) in synchronization with the stitch forming mechanism.

The bar is held in place with tapered screws and lock nut fasteners(136). End play adjustment is made by loosening the nuts and turning tapered screws inward until properly positioned.

One end of the feed raising bar is forked and fits over a roller cam(044) on adjusting block(049).

To adjust feed dog height, loosen the screw on adjusting block and move either up or down to adjust.

If feed dog is too low, push adjusting block upward slightly. If feed dog is too high, reverse the procedure. Tighten set screw and test sew.

Proper feed dog height setting is 1/32" above needle plate surface at it's highest point.

The drop feed mechanism is located on the adjusting block. Singer 15-88 thru 15-91 feature a slotted thumb screw. To activate, raise machine head and loosen screw until block drops free.

On imports with top bed control a button is utilized. When the button is turned, a arm pulls a tapered pin and the block drops. When button is returned to feed, the tapered pin slips back in hole and the block raises.

If user complains machine isn't feeding and machine has a drop feed, look at the adjusting block assembly first.

Needle plate.

Check the needle plate on each service call. If the needle hole is damaged from numerous needle strikes, replace it. If narrow strips of metal between feed dog slots are bent or cracked, replace the plate.

On slightly damaged needle holes, smooth with emery cord but don't enlarge the needle hole.

Always clean dirt and lint from under needle plate.

Balance wheel, clutch assembly and bobbin winder.

Except for Singer gear driven 15-91, most 15 class machines have grooved balance wheel for belt drive, either belt or electric.

The wheel rides on collar(038), which fits over end of main shaft and is pinned in place with a tapered pin. Some models feature a counterbalance at this point.

The clutch washer fits over the collar next to the balance wheel; where it is held in place by a knurled control knob.

A threaded pin in the knob acts as a stop when the clutch is engaged.

The clutch knob is loosened, counterclockwise, allowing the balance wheel to turn while the machine remains inert. When the knob is tightened, clutch washer is pushed against the wheel and the machine is re-activated. Clutch is used primarily for winding the bobbin.

If the machine runs sporadically, or the knob won't stay tight, the clutch washer is probably on wrong.

Loosen set pin and remove clutch knob.

Remove clutch washer and turn 180 degrees. Replace on collar with inverted fingers pointing inward.

Replace knob, insert stop screw. Test sew.

The bobbin winder is automatic except on older 15-30 machines. When the bobbin is full, the winder is pushed away from the balance wheel.

Treadle machines have a winder that rides on the treadle belt. Electric machines have a rubber ring that rides against the balance wheel.

If winder shuts off too soon, bend guide finger slightly away from spindle. If bobbin fills too full, reverse adjustment and bend finger outward.

Replace rubber ring on every service call.

On machines with thread guide on bed, loosen set screw and move guide away from side thread piles up. Make small adjustments until corrected.

One end of the feed raising bar is forked and fits over a roller cam(044) on adjusting block(049).

To adjust feed dog height, loosen the screw on adjusting block and move either up or down to adjust.

If feed dog is too low, push adjusting block upward slightly. If feed dog is too high, reverse the procedure. Tighten set screw and test sew.

Proper feed dog height setting is $1/32''$ above needle plate surface at it's highest point.

The drop feed mechanism is located on the adjusting block. Singer 15-88 thru 15-91 feature a slotted thumb screw. To activate, raise machine head and loosen screw until block drops free.

On imports with top bed control a button is utilized. When the button is turned, a arm pulls a tapered pin and the block drops. When button is returned to feed, the tapered pin slips back in hole and the block raises.

If user complains machine isn't feeding and machine has a drop feed, look at the adjusting block assembly first.

Needle plate.

Check the needle plate on each service call. If the needle hole is damaged from numerous needle strikes, replace it. If narrow strips of metal between feed dog slots are bent or cracked, replace the plate.

On slightly damaged needle holes, smooth with emery cord but don't enlarge the needle hole.

Always clean dirt and lint from under needle plate.

Balance wheel, clutch assembly and bobbin winder.

Except for Singer gear driven 15-91, most 15 class machines have grooved balance wheel for belt drive, either belt or electric.

The wheel rides on collar(038), which fits over end of main shaft and is pinned in place with a tapered pin. Some models feature a counterbalance at this point.

The clutch washer fits over the collar next to the balance wheel, where it is held in place by a knurled control knob.

A threaded pin in the knob acts as a stop when the clutch is engaged.

The clutch knob is loosened, counterclockwise, allowing the balance wheel to turn while the machine remains inert. When the knob is tightened, clutch washer is pushed against the wheel and the machine is re-activated. Clutch is used primarily for winding the bobbin.

If the machine runs sporadically, or the knob won't stay tight, the clutch washer is probably on wrong.

Loosen set pin and remove clutch knob.

Remove clutch washer and turn 180 degrees. Replace on collar with inverted fingers pointing inward.

Replace knob, insert stop screw. Test sew.

The bobbin winder is automatic except on older 15-30 machines. When the bobbin is full, the winder is pushed away from the balance wheel.

Treadle machines have a winder that rides on the treadle belt. Electric machines have a rubber ring that rides against the balance wheel.

If winder shuts off too soon, bend guide finger slightly away from spindle. If bobbin fills too full, reverse adjustment and bend finger outward.

Replace rubber ring on every service call.

On machines with thread guide on bed, loosen set screw and move guide away from side thread piles up. Make small adjustments until corrected.

Parts breakdown - Japanese HA - 1

Figure 46

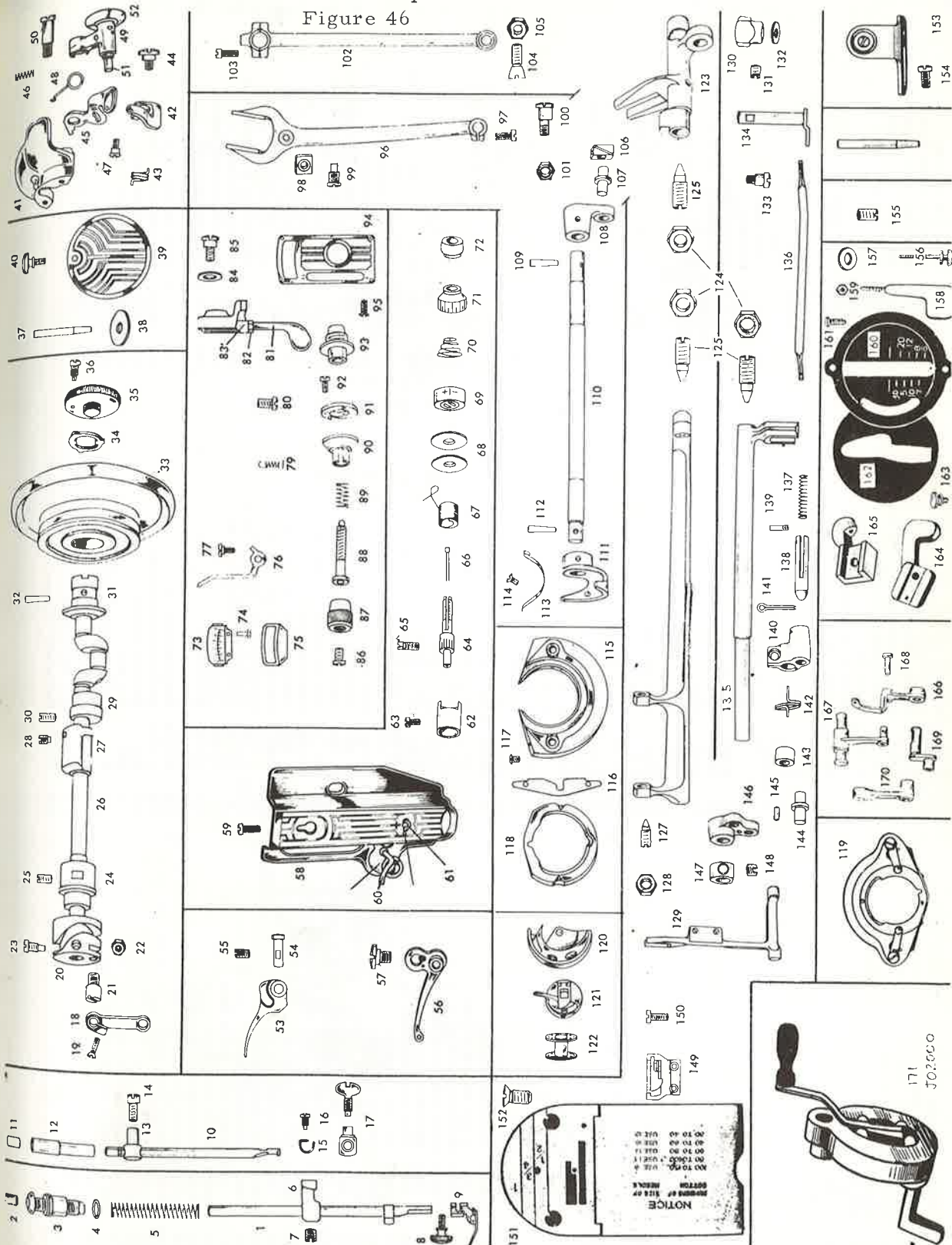

Parts list for Japanese HA-1, figure 46

1	JO1140	Presser Bar	59	J 1189	Face Plate Screw	121	JO1313	Bobbin Case Complete
2	B27	Felt for Darnet	60	JO1107	Tension Thread Guard		JO1314	Bobbin Case Tension Spring
3	J3711	Automatic Darnet	61	JO1103	Face Plate Thread Guide		J 1585	Bobbin Case Tension Spring Screw
4	JO1142	Presser Bar Spring Washer	62	JO1106	Tension Stud Bushing		JO1318	Bobbin Case Latch Complete
5	JO1141	Presser Bar Spring	64A	J 2748	Tension Stud		JO1321	Bobbin Case Latch Spring
6	JO1143	Presser Bar Guide Bracket	65	JO1110	Takeup Spring Regulator Screw	122	J 1586	Bobbin Case Latch Screw
7	J 1448	Presser Bar Guide Bracket Screw	66	JO1115	Tension Release Pin	123	JO1322	Bobbin
8	J 3675	Presser Foot Thumb Screw	67	JO1113	Takeup Spring	124	JO1331	Oscillating Rock Shaft
9	JO1155	Presser Foot	68	JO1111	Tension Discs	125	J 16	Center Screw Nut
10	JO1122	Needle Bar	69	JO1109	Tension Seat	126	JO1430	Feed Rock Shaft
11	B27	Felt for Needle Bar Bearing	70	JO1114	Tension Spring	127	J 1305	Center Screw
12	JO1123	Needle Bar Bushing	71	S 024	Tension Dial	128	J 16	Center Screw Nut
13	JO1124	Needle Bar Connecting Stud	72	J 56	Tension Nut	129	JO1415	Feed Bar
14	J 1154	Needle Bar Set Screw	73	B2624	Stitch Dial	130	B216	Drop Feed Knob
15	JO1128	Needle Bar Thread Guide	74	B9	Rivet for Stitch Dial	131	B218	Drop Feed Knob Set Screw
16	J 1249	Needle Bar Thread Guide Screw	75	B2625	Window for Stitch Dial	132	B2669	Drop Feed Indicator
17A	JO1127	Needle Clamp Complete	76	B2619	Stitch Indicator	133	B211	Hinge Stud For Drop Feed Rod
18	JO1125	Needle Bar Connecting Link	77	B2620	Stitch Indicator Screw	134	B967	Drop Feed Knob Rod
19	J 3444	Needle Bar Connecting Link Adjusting Screw	79	B2621	Stitch Indicator Spring	135	JO1410	Feed Lifting Rock Shaft
20	JO1209	Thread Takeup Cam	80	B185	Screw for Stitch Regulating Knob	136	B210	Drop Feed Connecting Link
21	J 1564	Needle Bar Connecting Link Hinge Screw	81	B2016	Feed Regulating Lever	137	B208	Spring For Split Shaft
22	J 18	Needle Bar Connecting Link Hinge Screw Nut	82	B176	Nut for Feed Regulating Lever	138	B207	Split Shaft For Drop Feed
23	J 2277	Thread Takeup Cam Position Screw	83	B172	Feed Regulator	139	B212	Screw for Drop Feed Connecting Link
24	JO1202	Upper Shaft Bushing	84	B173	Feed Regulating Washer	140	B205	Drop Feed Elbow Link
25	J 1430	Upper Shaft Bushing Set Screw	85	B69	Screw For Feed Regulator	141	B209	Center Pin
26	JO1201	Upper Shaft	86	B185	Stitch Regulating Knob Screw	142	B206	Spring for Drop Feed
27	JO1208	Balance Weight	87	B183	Stitch Regulating Knob	143	B84	Vertical Feed Arm Roller
28	J 3505	Balance Weight Set Screw	88	B2618	Stitch Regulating Screw	144	B85	Stud for Vertical Arm Roller & Lower Shaft
29	JO1401	Feed Cam	89	B181	Stitch Regulator Spring	145	B203	Pin for Vertical Feed Arm
30	J 2269	Feed Cam Set Screw	90	B2615	Stitch Regulating Tube	146	B202	Vertical Feed Arm
31	JO1205	Balance Wheel Bushing	91	B2616	Stitch Regulating Cam	147	B204	Collar for Vertical Feed Shaft
32	JO1207	Balance Wheel Bushing Pin	92	B2617	Stitch Regulating Fastening Screw	148	B68	Set Screw for Collar
33	JO1204	Balance or Disc Wheel	93	B2614	Stitch Regulator Body	149	JO1450	Feed Dog
34	JO1206	Clamp Stop Motion Clamp Washer	94	B2624	Stitch Regulator Cover Plate	150	J 1207	Feed Dog Screw
35	J 1254	Clamp Stop Motion Screw	95	B2626	Stitch Regulator Cover Plate Screw	151	S1163	Combination Slide & Needle Plate
36	J 1246	Clamp Stop Motion Screw	96	JO1402	Forked Rod		J11138	Slide Plate Spring
37	JO1008	Spool Pin	97	J 1174	Forked Rod Screw		J13726	Slide Plate Spring Screw
38	JO1009	Spool Pin Felt Washer	98	JO1406	Feed Connecting Slide Block	152	J 1681	Needle Plate Screw
39	JO1012	Arm Side Cover	99	J 2070	Feed Connecting Slide Block Stud	153	B155	Bobbin Winder Tension Complete
40	J 3675	Arm Side Cover Screw	100	J 2364	Feed Fork Connection Hinge Screw	154	B137	Screw for Bobbin Winder Tension
41A	JO1501	Bobbin Winder Assembled	101	B22	Feed Fork Connection Hinge Screw Nut	155	B13	Head Hinge Screw
42	JO1502	Bobbin Winder Body	102	JO1334	Crank Connection Rod	156	J3676	Feed Regulator Thumb Screw
43	JO1511	Stop Latch	103	J 1884	Crank Connection Rod Cap Screw	157	JO1405	Feed Regulator Screw Washer
44	J 3750	Stop Latch Spring	104	J 1370	Crank Connection Rod Hinge Screw	158	S041	Feed Regulating Lever
45	JO1504	Stop Latch Tension Plate	105	J 1118	Crank Connection Rod Hinge Screw Nut	159	S040	Feed Regulating Lever Nut
46	B747	Stop Latch Spring	105, 78	JO1326	Oscillating Shaft Crank and Slide Block	160	S004	Outside Plate of Stitch Regulator
47	J 1157	Bobbin Winder Bracket Screw	109	JO1130	Oscillating Shaft Crank Taper Pin	161	S003	Outside plate Screw
48	JO1505	Bobbin Winder Spring	110	JO1325	Lower Shaft	162	S005	Inside Plate of Stitch Regulator
49	JO1503	Bobbin Winder Spindle Holder	111	JO1310	Shuttle Driver	163	S008	Stitch Regulator Screw
50	J 3766	Bobbin Winder Frame Hinge Screw	112	JO1330	Shuttle Driver Set Pin	164	JO1403	Feed Regulator
51	JO1506	Bobbin Winder Spindle	113	JO1310A	Shuttle Driver Spring	165A	B3957	Link Takeup Lever Complete
52	J 1509	Bobbin Winder Friction Ring	114	J 1653	Shuttle Driver Spring Screw	167	B275	Takeup Lever Link
53	JO1145	Presser Bar Lifter	115	B219	Race Body Complete	168	B275	Takeup Lever Rivet
54	JO1146	Presser Bar Lifter Stud	116	B220	Race Body	169	B1514	Needle Bar Crank
55	019	Presser Bar Lifter Stud Set Screw	117	B105	Shuttle Race Cap (JO1307A)	170	B2432	Needle Bar connecting Link
56	JO1211	Takeup Lever with Stud	118	B221	Shuttle Race Cap (J 1653)	171	JO2000	Hand Crank Complete
58A	JO1101	Face Plate Assembled	119	JO1303	Shuttle Race Cover (JO1304)			
58	JO1102	Face Plate Body	120	JO1308	Shuttle Body			

Riccar Model RW 8 Straight Stitch Sewing Machine.

1. NAME OF PARTS

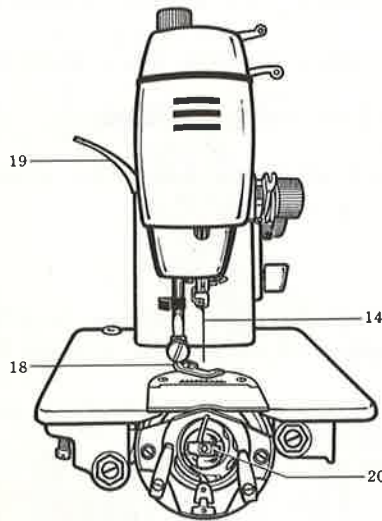
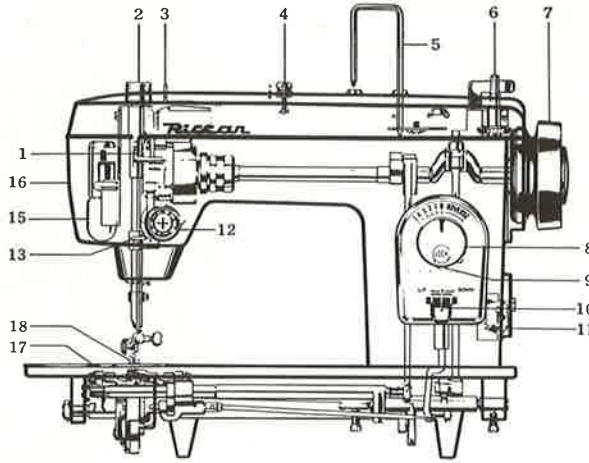

- 1) Thread Take-up Lever
- 2) Pressure Regulator
- 3) Arm Thread Guide
- 4) Bobbin Winding Thread Guide
- 5) U-shape Spool Pin
- 6) Bobbin Winder
- 7) Hand Wheel
- 8) Stitch Length Regulating Knob
- 9) Locking Dial
- 10) Drop Feed Knob
- 11) Built-in Light Switch
- 12) Dial Tension
- 13) Thread Guide
- 14) Needle
- 15) Built-in Light
- 16) Face Cover
- 17) Hinged Needle Plate
- 18) Hinged Presser Foot
- 19) Presser Bar Lifter
- 20) Open Race

Needle Bar Crank
 Needle Bar connecting Link
 Hand Crank Complete
 JO2000
 169 B1514
 170 B2432
 171 JO2000
 Shuttle Race Cap (JO1307A)
 Shuttle Race Cap Screw (J 1653)
 Shuttle Race Cover (JO1304)
 Race Body Complete
 Shuttle Body
 B226
 B105
 B221
 JO1303
 JO1308
 Presser Bar Lifter Stud
 Presser Bar Lifter Stud Set Screw
 Takeup Lever with Stud
 Takeup Lever Set Screw
 Face Plate Assembled
 Face Plate Body
 JO1146
 019
 JO1211
 J 2980
 JO1101
 JO1102
 54
 55
 56
 57
 58A
 58

Upper Tension

The upper tension on the RW-8 Riccar is located on the front of the machine arm, and has the link take-up arm mechanism described on page 45.

To remove the tension assembly, open front face plate door. Use the tension screwdriver from your kit and loosen set screw(a), located directly opposite the tension (figure 48).

Figure 48

Remove tension assembly by pulling outward, toward you.

Loosen both screws holding stud in tension block.

To dismantle, remove adjustment knob, then balance of exterior components.

Lay parts out, in the order of their removal.

Inspect tension discs for thread cuts. If either of the discs are thread cut, replace them.

If operator complains that tension doesn't release when presser bar is lifted, check the release pin (slender pin that fits in tension stud). If it's worn, or bent, replace it.

Inspect the check spring. If broken or bent, replace it. The check spring must be adjusted with proper throw. It must release the thread when eye of needle enters the cloth.

If check spring is too tight, turn tension stud, clockwise, slightly.

Push stud into tension block. Hold in place and tighten set screws.

If the check spring is too loose (doesn't hold thread long enough) reverse the procedure and turn tension stud counterclockwise. Hold stud in place and tighten set screw (or screws if there are two).

Replace tension assembly in machine. Tighten set screw, close face plate door.

Adjust tension by turning dial to proper setting. Follow procedure from pages 40, 41 and 42.

Most Riccar sewing machines have a similar tension assembly. For a complete component breakdown, see page 82.

Adjust dial to a setting of from 3 to 5, which allows a range for either a loose, or tight stitch, from the regular sewing setting.

Lower Sewing Mechanism

The components are basically class 15, as illustrated on page 36. Figure 49a and b, illustrate components, and method of removing shuttle from shuttle. See page 53.

Before removing shuttle assembly, be sure needle is at its highest point. Tilt head back on hinges, and remove bobbin case (1).

Turn levers (3), and swing race cover down. (It's hinged).

Remove shuttle-hook by pulling outward.

Check hook for needle strikes, or broken point. If point is broken, replace it. If needle strikes aren't too severe, smooth with fine grade emery paper. Wipe away all particles.

Check race area for accumulated lint or broken threads. Clean race area thoroughly.

Spread a thin layer of clear household oil over outer rim of shuttle, and replace components in reverse order of removal.

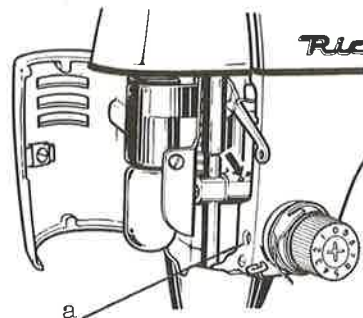
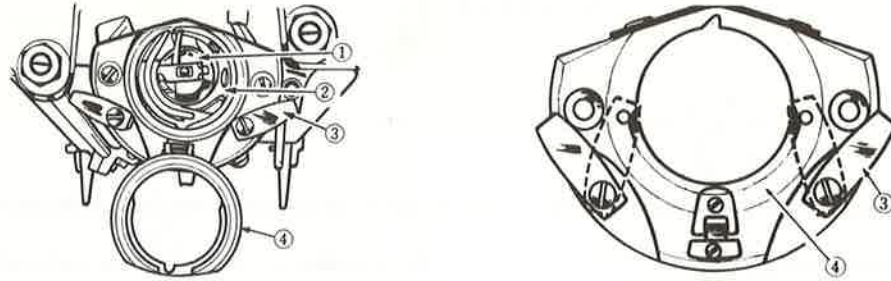

Figure 49



Since the RW-8 mechanism is basically class 15, earlier text from this chapter can be used for adjustment.

The bobbin winder assembly is vastly improved, and as on most streamlined machines is enclosed, except for the spindle and release finger.

To wind the bobbin on the RW-8, loosen clutch (figure 50, #2).

Follow threading instruction (figure 50A). Wind thread around bobbin a few turns, then place bobbin on spindle (#2, figure 50A).

Press winder finger (#3, figure 50A), inward until it clicks. As winder turns, bobbin is filled, and it pushes finger outward. When bobbin is full, the finger is pushed away and the winder stops.

When bobbin is properly wound, it should look like (A, figure 50B). If the wound bobbin looks like any of the other three examples, the winder must be adjusted.

Check winder finger (3, figure 50A). If bent or marred, correct as required.

Check tensioning device (figure 50A). It controls thread as it passes into the bobbin. Loosen screw for less tension, tighten for more. Clean all lint and dust away from the part.

Test bobbin winder and observe. Correct if needed.

Figure 50

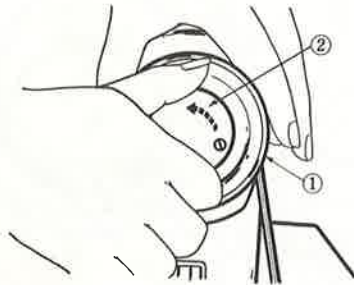

Figure 50A

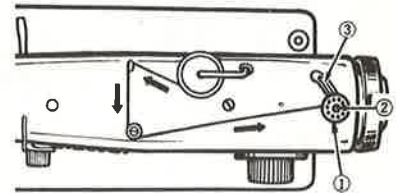
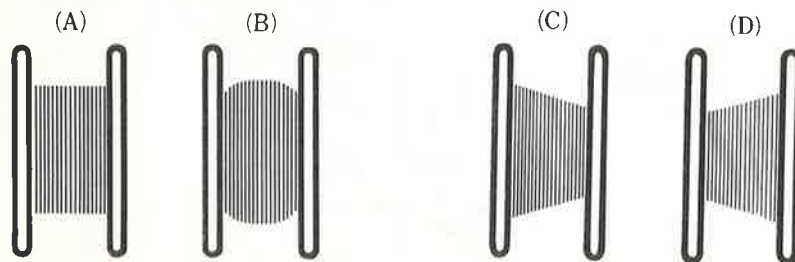

Figure 50B



Oscillating Hook Sewing Machine(Class 66)

The 66 class sewing machine is a top bobbin oscillator with horizontal shuttle.

Singer manufactured the machine as the 66 series and when the patents expired, several Japanese manufacturers produced the machine under a variety of names. Bel-Air 600, Sewmor 303, Morse, Brother and Universal, to name a few.

With the exception of the Singer 66-1, which has a back attached presser foot and slightly different hook-bobbin case arrangement, this chapter will cover all machines of the 66 variety.

Where adjustment covers the 66-1, it will be so noted.

Singer made a three-quarter version of the 66 class, known as the 99-13 or 99K if manufactured in their England plant.

The Japanese also manufactured, marketed and exported this machine under a variety of names.

The Singer 99 was primarily a portable and never sold on a level with the 66 due to its size. It was used mainly for leader advertising and selling.

Basically, the Class 66 is the smoother, easier running of the oscillator type. In fact there are thousands of 66-1 machines in operation and many were manufactured before 1900.

Figure 50

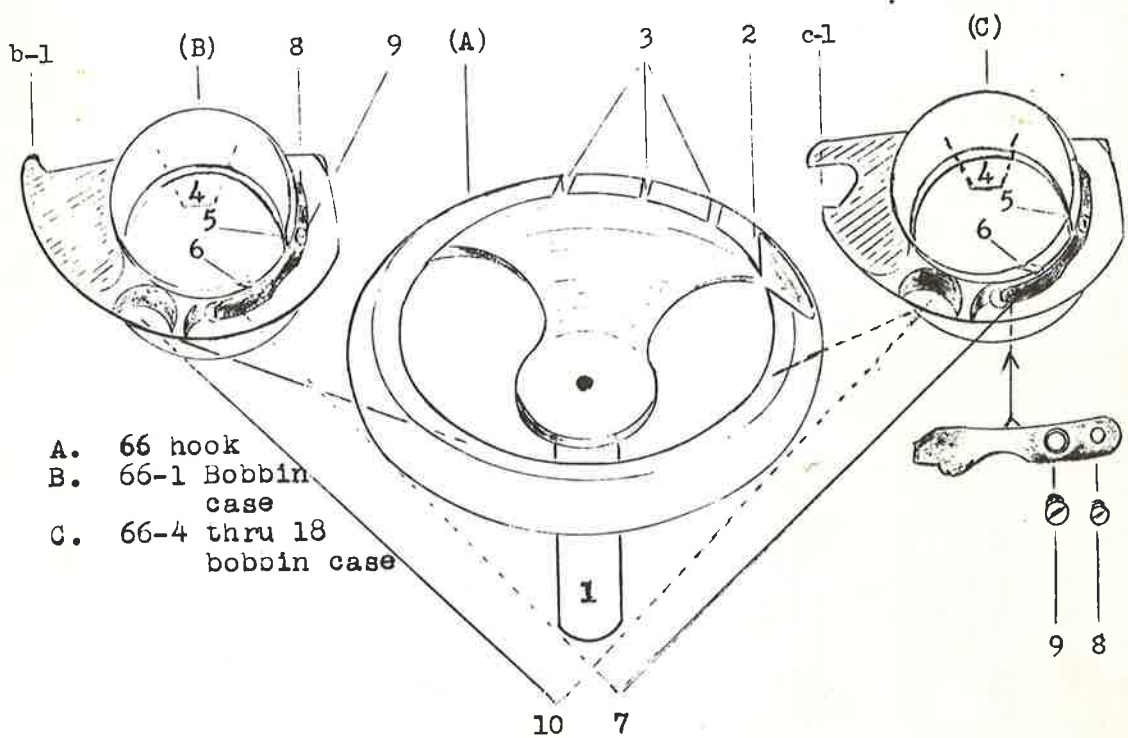
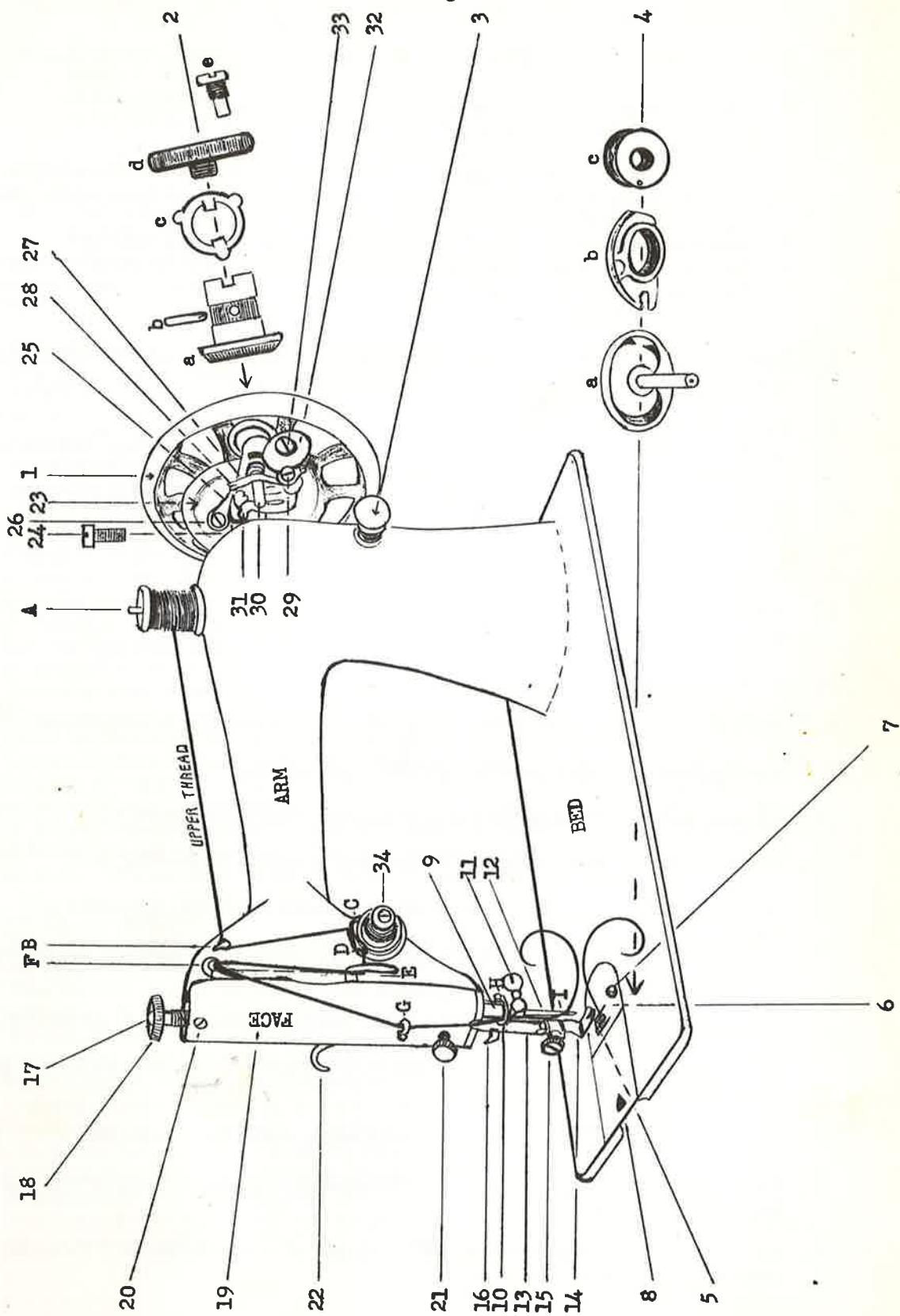

Figure 51 Class 66 sewing machine.



Components - Class 66, 99, 600 and 900.

1. Balance wheel. Serves as drive, either by belt, pulley or crank.
2. Clutch assembly. Disengages machine for winding bobbin.
 - a. Collar. Balance wheel rides on the collar.
 - b. Pin. Holds collar to main shaft. Pin is tapered.
 - c. Clutch washer. Fits against wheel. When clutch is disengaged, washer moves away from wheel, allowing wheel to turn while the machine remains inert.
 - d. Knurled release knob. Loosens clutch for winding bobbin.
 - e. Stop screw. Works between knobs on clutch washer when release knob is loosened or tightened. Prevents release knob from coming off machine.
3. Stitch Control knob. Regulates length of stitch. Found on older 66 machines. All later models feature a reverse lever or back tack.
4. Lower sewing mechanism.
 - a. Hook. Attaches to lower drive and moves in oscillating motion in rhythm with upper drive as point of hook picks up top thread.
 - b. Bobbin case. Fits on hook. Bobbin is inserted from top.
 - c. Bobbin. Round type. Lower thread is wound on it.
5. Feed dog. Moves cloth from lower side.
6. Needle plate. Covers feed dog except where teeth appear through slots to move material. Two screws hold it in place.
7. Screws. Hold needle plate in place.
8. Throat plate. Covers hook assembly. Slide back to insert bobbin.
9. Needle bar. Drives needle in stitch formation.
10. Thread guide. Guides thread for smooth entry into needle.
11. Needle clamp. Holds needle in proper position on needle bar.
12. Needle. Carries upper thread down to hook in stitch formation.
13. Presser bar. Holds presser foot and contains vehicle for adjusting pressure on cloth.
14. Presser foot. Holds cloth firmly so feed dog can move it properly.
15. Thumb screw. Holds presser foot on presser bar. Attachments go on machine with this screw.
16. Thread cutter. For cutting threads when seam is completed.
17. Pressure adjusting screw. Used for changing upper pressure for various types of fabric.
19. Face plate. Covers mechanism in front of machine head. Take-up, needle bar, presser bar, etc.

- 20, 21. Face plate screws.
22. Presser bar lifter. Lifts presser bar and presser foot. It also serves as tension release agent. When lifter is raised, it activates a lever which presses against tension release pin, allowing top thread to move freely through the tension discs.
- 23-33. Bobbin winder assembly. Winds bobbin for lower thread.
34. Upper tension assembly. Consists of Tension base and screw, check spring, stud, release pin, tension discs(2), release disc, tension spring and tension adjusting nut.

Upper tension.

To remove tension stud, loosen set screw under machine arm and pull toward you. The tension is unitized and will come out of machine in a unit.

When any assembly is broken down, always place the components in the order they are removed from the machine.

Remove tension adjusting nut(calibrated dial on later models) from stud. The balance of assembly will slide off the stud easily. First the tension spring, then the release disc, tension discs and release pin.

Check tension release disc. If the release is bent from years of hard use, replace it.

Check tension discs. If they are thread cut, replace them.

Check spring. If the check spring is bent or broken, replace it. Replace adjusting nut, insert screwdriver in stud and remove stud from base. Pull old spring out and replace with a new one.

Spring fits over stud with small finger over groove. Place on stud and adjust proper tension.

Replace stud in tension base before inserting base in machine head. Check spring groove must be flush with machine head. Tighten set screw.

Ideal adjustment places groove slightly above center.

Check spring should release thread as needle enters the cloth. If spring holds the thread too long, loosen set screw and turn base upward. When the opposite is true, reverse the procedure. Tighten set screw and test sew.

- When tension doesn't hold adjustment, remove adjusting nut and spread tension stud as needed. Replace adjusting nut, turn to proper setting and test sew. (Procedure is illustrated in chapter one, page 16).

Lower tension.

The bobbin case is grooved and fits over the hook as it travels back and forth to pick up the top thread and help form the stitch.

The bobbin drops in case from above with the thread coming off counter-clockwise, through the tension spring and out the top.

To adjust, set upper tension then remove bobbin case from machine. Flip lower prong of bobbin case holder toward you, and lift bobbin case out. (66-1 series has a screw which must be removed). See figure 50.

Loosen small adjusting screw with tension screwdriver and tilt upward. If the spring is thread cut, replace it. In most cases, the presence of lint or dirt will be enough to distort tension.

Replace the spring, adjust to proper tension.

Replace the bobbin case and test sew. Adjust as needed.

Put a drop of oil on red felt adjacent to hook. If red felt is missing, replace in small coiled spring at lower right, near needle plate.

Timing.

Unlike the class 15 and long shuttle machines covered in the first two chapters, timing can be a problem on the 66.

After checking hook for broken point and inserting a new needle, if the machine still doesn't pick up the lower thread, the machine may be out of time.

Timing the needle bar.

Figure 52

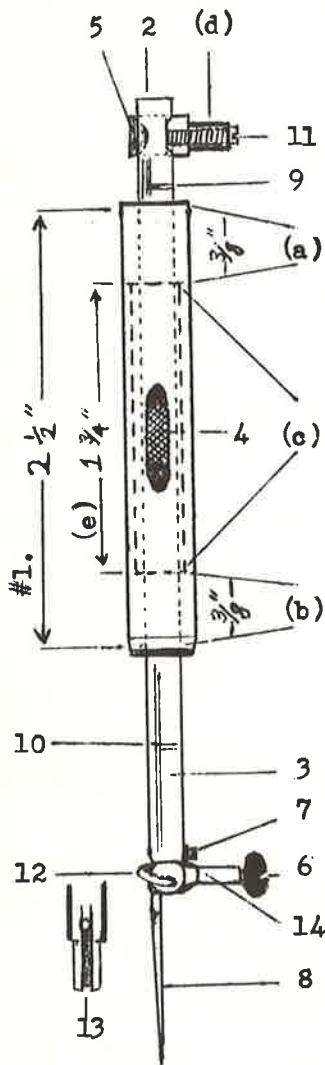

The 66 class features a linktake-up system with a short needle bar. The needle bar (3), moves in a bushing(1) set in face plate cast.

If the needle bar moves too freely in the bushing, it should be replaced.

The older 66 machines have a timing mark on the needle bar.

Turn the balance wheel until needle bar is at lowest point.

Remove the face plate.

Insert screwdriver in hole cut in rear cast. Move balance wheel until screwdriver touches screw(11).

Loosen screw and move needle bar until the timing mark(9) is flush with connecting link, when link is at lowest point.

Tighten screw and replace face plate.

Test sew.

Machines without a timing mark must be timed at the hook.

Remove needle plate, bobbin case and holder.

Turn balance wheel until needle is at lowest point, with take-up arm on downstroke.

The hook should start moving counterclockwise.

When the needle starts on upstroke, the eye should be $\frac{3}{32}$ " below point of hook.

If there is a variation, follow step one and make necessary adjustment.

Be sure hook is not broken when making this adjustment.

Replace all parts and test sew.

Always clean excess lint and dirt away from hook and feed dog. The 66 hook is a notorious dirt catcher.

Oil working parts and the red felt.

Disregard numbers not referenced since they are technical data only.

Timing the hook.

When the machine continues to skip stitches after the needle bar has been timed, check the hook.

Tilt head back and make adjustment from lower end.

The hook fits in a hook crank clamp which oscillates from the bell crank. The hook and clamp each have a timing mark. If the marks don't match, loosen set screw on clamp and turn hook until they do. Snug tighten the set screw. Check hook spindle and crank clamp position.

Lower end of spindle must be flush with clamp.

Tighten screw and test sew.

If the machine continues to skip stitches, the trouble may be in the rocker arm.

- To check, hold the hook in left hand and balance wheel with your right. If the hook moves more than 1/8", without moving the balance wheel, adjustment must be made at the upper main shaft, on the rocker arm.

Set machine head upright and remove rear cover plate.

Directly in front of you will be a fork-like object. This is the rocker arm (5) and it will probably be loose.

Drop a little penetrating oil on the screw facing you and let it soak. To loosen, use a strong screwdriver. When screw is loose, tighten it in small increments. Continue adjustment until play disappears.

Caution: Do not over-adjust. Turn balance wheel, if machine binds, the screw is too tight. Tighten with care, when a machine wears to this degree, the rocker arm may be very brittle and easily broken.

Replace cover plate and tilt head back.

At the lower end of rocker arm(5) is a tapered screw where the arm is attached to the lower drive shaft.

If there is excess play at this point, loosen lock nut and adjust tapered screw until play disappears.

Turn balance wheel, if machine binds, back the screw off until machine turns easily. Tighten lock nut and test sew.

Figure 53 illustrates relation of main shaft to lower end.

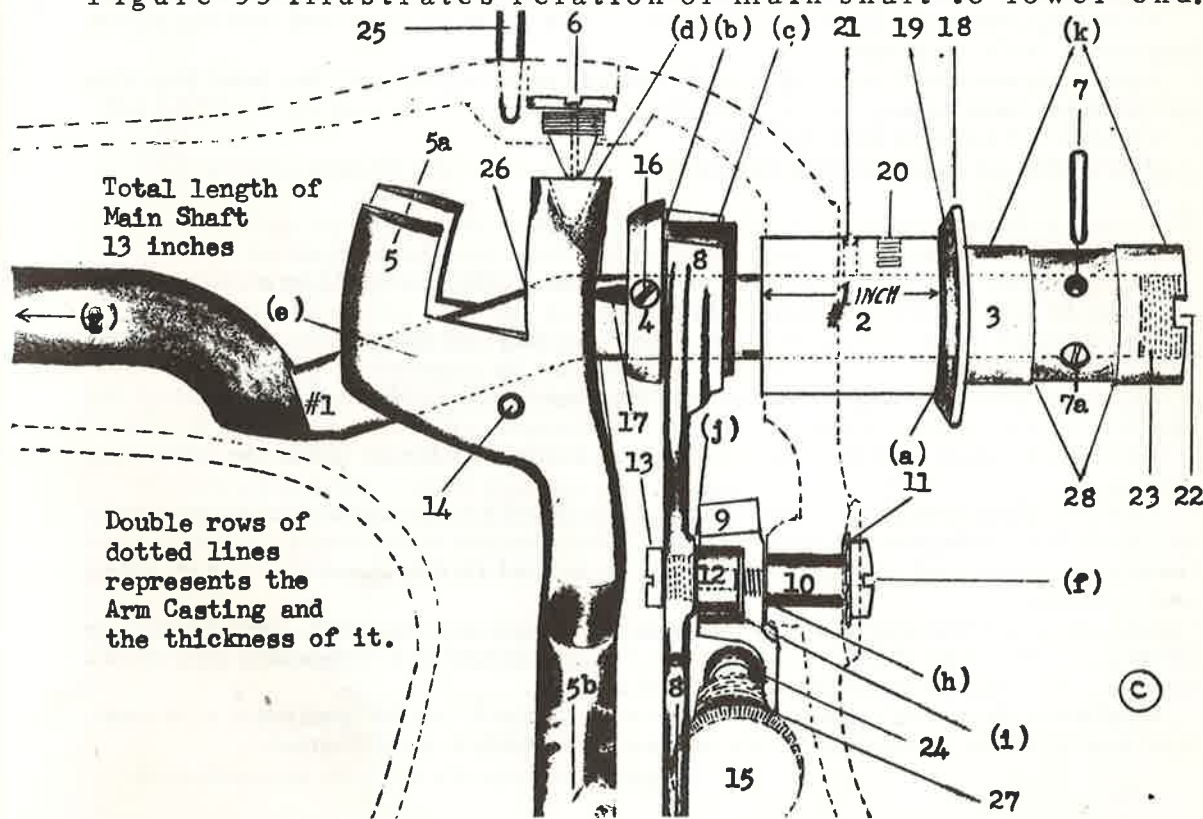

The feed system.

The feed fork(8) is activated by feed cam(4) which is attached to the main shaft(1) by set screw(16). See figure 53.

The main shaft is grooved and when set screw is properly inserted, the cam is automatically timed.

Stitch regulator(15) screws in the head and is attached to slide block(9), which fits over cam(12). The cam is attached to feed fork(8).

When the stitch regulator is changed, the block changes position and the cam follows, changing the throw of the feed fork and length of stitch.

Models with reverse lever have a longer block and when lever is moved past center line, the block changes cam flow and machine sews reverse.

The lower feed bar is held in place by two tapered screws and lock nuts. When the bar has side play, loosen lock nuts at each end of bar. Turn tapered screws inward until bar is snug. Tighten lock nuts. Avoid over-adjustment.

If machine binds, loosen lock nuts and back tapered screws off slightly.

To adjust feed fork and lower feed bar, loosen lock nut and turn eccentric screw as needed.

Turn stitch regulator out, to extreme adjustment.

Turn balance wheel and observe feed dog motion. They should move up and down in same position with no horizontal travel.

If any travel is noted, turn eccentric screw until corrected.

Tighten lock nut. Hold eccentric screw firmly. Test sew.

The 66 class feed dog has an elongated slot to compensate for excessive wear. To adjust, loosen the screw and move feed dog proper direction. Up for more feed, down for less.

Correct height for everyday sewing is 1/32" above needle plate at its highest point. A feed dog set too high will jerk material and create puckering.

When adjusting the feed dog, loosen needle plate screws and set the stitch regulator for a long stitch.

Turn balance wheel manually and observe needle plate. If the feed dog hits or touches plate at any point, re-adjust feed dog.

Tighten all screws and test sew.

If feed dog is badly worn, replace it.

Presser bar.

The presser bar exerts pressure and helps guide material in straight line working in conjunction with the feed dog.

The presser foot is shaped to fit over feed dog and exert equal pressure on material. Amount of pressure is determined by regulating screw.

The presser bar lifter raises and lowers bar in addition to releasing the tension by activating tension release pin.

The lifter block attaches to the bar and serves as lower base for adjusting spring.

Later models feature the automatic darning. The darning button is graduated for different degrees of pressure. When released completely, all pressure leaves presser foot and material may be moved in any direction for darning and mending.

The presser foot and all attachments fit on presser bar with a thumb screw arrangement. The thumb screw is generally slotted for tightening by screwdriver. Use it, especially on the buttonholer.

Machines that don't have an automatic darning can be equipped with one. Remove knurled adjusting screw and replace with a patchomatic.

Slide plate.

Any user of a class 66 sewing machine will at some time have trouble keeping the slide plate on her machine.

A flat spring fits on machine cast and is held in place by a set screw. The slide plate is grooved and slides over the spring ends, into place. Invariably the spring will break and slide plate will not stay in place.

To replace, loosen screw(3) and remove old spring. Place new spring on machine with ends pointing upward. Tighten spring until ends hold plate firmly in place.

Figure 54

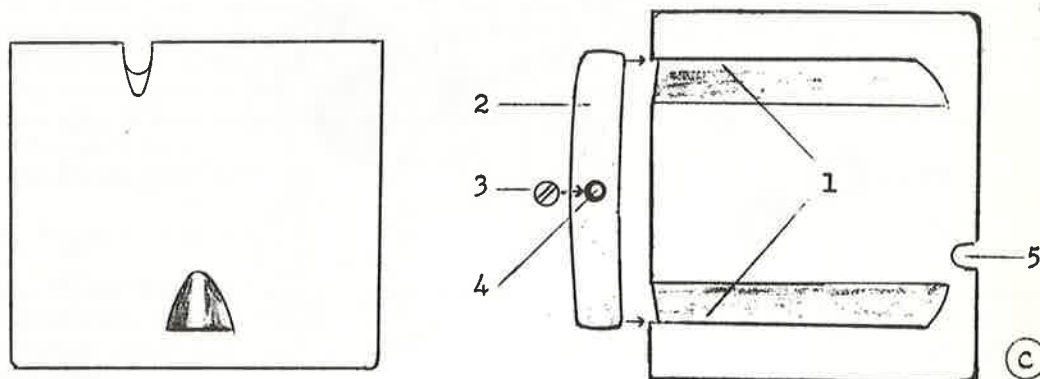

Bobbin Winder.

The bobbin winder fits on a hood which attaches machine over the balance wheel.

Bobbin fits on spindle(8), thread is threaded into guides(19 and 20).

Winder is depressed until rubber touches balance wheel and catch lever(3) slips over stop(30). As the winder turns, lever(22) moves thread back and forth in even motion. As the bobbin fills, finger(26) is pushed back until, when bobbin is full, catch lever is pushed away and rubber leaves balance wheel.

If winder overfills, loosen screw(7) and move winder up slightly. If opposite is true, reverse the procedure.

Replace bobbin winder rubber on each service call.

Clutch assembly works exactly like class 15 series. See page 48.

Illustration of bobbin winder is on page 62, figure 55.

Electrical equipment.

All phases of electrical operation pertaining to all sewing machines in this book will be covered in chapter 8.

Attachments.

Attachments will be covered in chapter 9.

Component breakdown of typical 66 class bobbin winder.

Figure 55

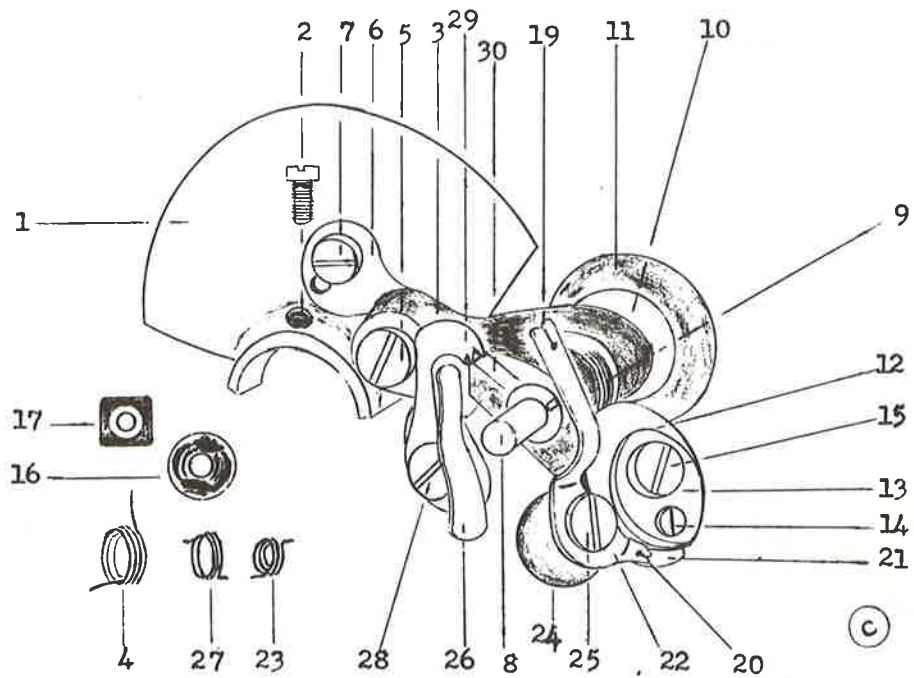

Chapter Four

The Rotary.

The rotary is the third type mechanism to be covered, so called because the sewing hook makes a complete revolution each time a stitch is formed.

There are many types of rotary mechanisms. The White, most famous and certainly the finest example of a simple rotary mechanism, employs a slide block and bearing arrangement to drive the shuttle.

Singer models 101, 201, later model slant needle, and automatic models use a gear drive rotary mechanism.

The Free Westinghouse-New Home machines were gear driven rotaries.

Most European Zig Zag's are gear driven rotaries with transverse hooks.

The rotary is generally a smoother operating machine, although a few latter day American made White owners might disagree.

Since the White is a prime example of rotary action, it will be covered in this chapter.

A later chapter will cover other rotary machines.

The White Rotary.

The White Rotary was manufactured by the White Sewing Machine Company of Cleveland, Ohio. Their machines were always top quality and ranked behind Singer until the early 1950's when imported machines began to dominate the market.

Had the White company chosen to adopt imports in 1950, they would undoubtedly be the number one sewing machine company in the United States today. They finally did so, but a glory that might have been slipped from their grasp.

Service and adjustment procedures set forth in this chapter can also be adapted to contract brands made by the White Company.

Brand names include, Domestic, Franklin, Kenmore (American made), the Wilson, Mason, Majestic and Dressmaster.

Figure 56

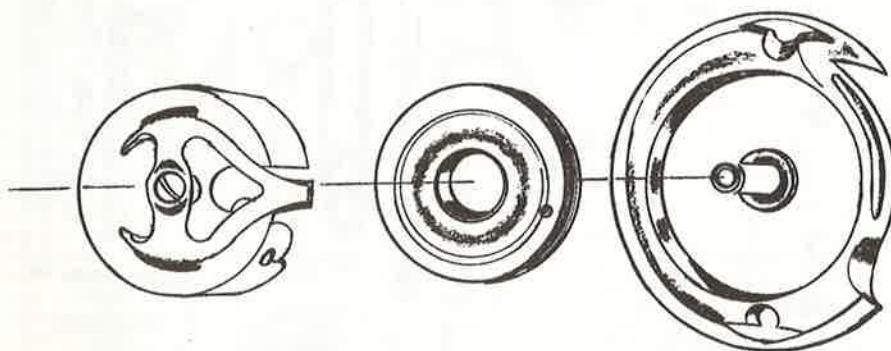

Component parts - FR White. Figure 57

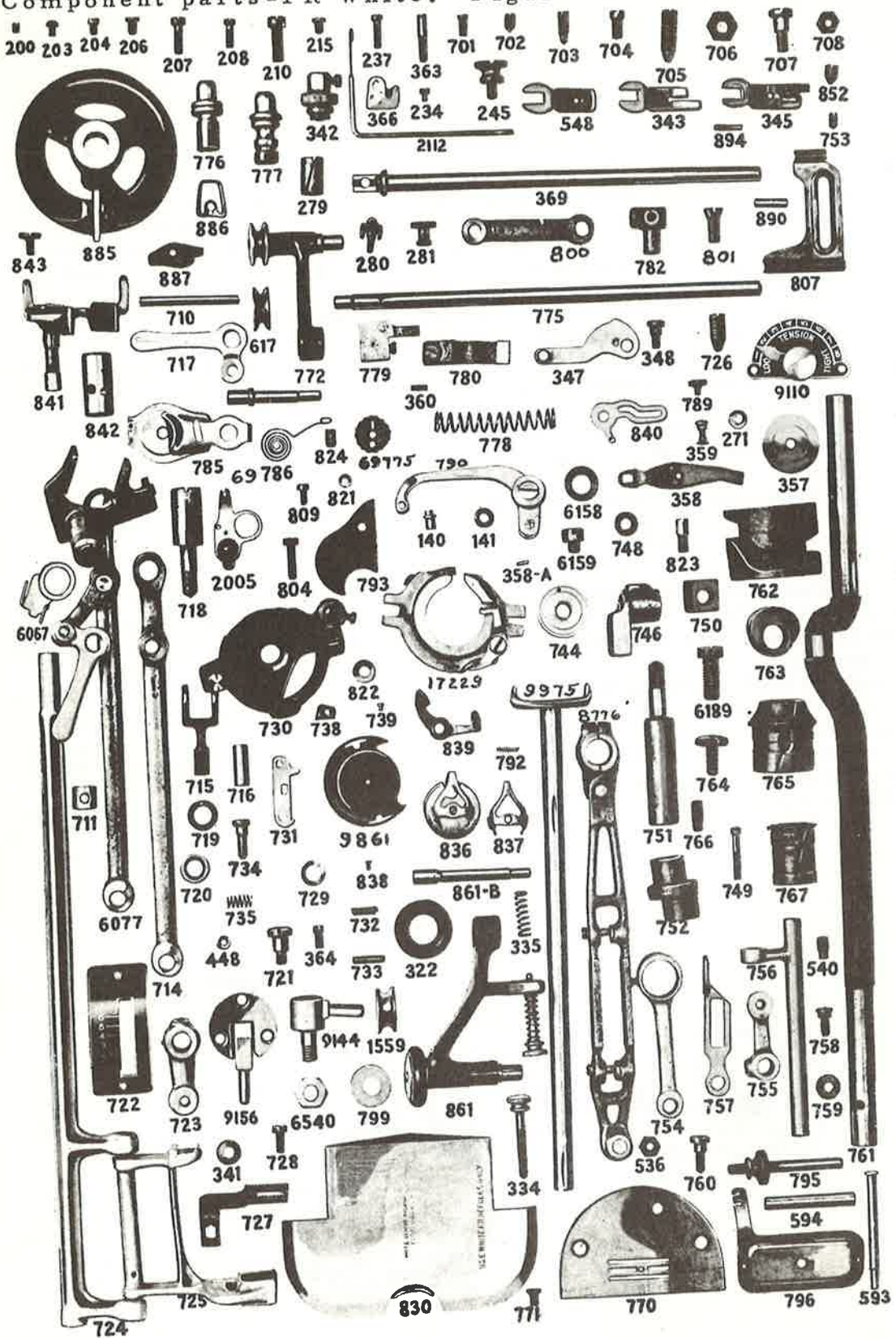

Components parts list - FR White.

NO.	DESCRIPTION	NO.	DESCRIPTION
40	Take-up roll stud	746	Crank and set screw assembly on rear end of 808 shuttle shaft
41	Take-up roll	8776	Main connection assembly
200	Take-up screw for needle bar bushing 279	749	Screw to adjust main connection to slide block
203	Screw to fasten tension indicator assembly to face plate	750	Main connection slide block Order 8776
204	Screw to fasten 342 to 775	751	Main connection stud Order 8776
206	Screw to fasten 755 to 756	752	Feed raising and thread pull-off cam assembly
207	Take-up screw on bearing to feed arbor	753	Screw to fasten 752 to 808
208	Screw to bind 760 in 730	754	Eccentric connection for thread pull-off
210	Screw to fasten face plate to arm	755	Thread pull-off rock arm
215	Screw to fasten 780 to 775	756	Thread pull-off rock shaft
233	Quilter Guide	757	Thread pull-off
234	Screw to fasten quilter guide and 366 to presser bar	758	Screw to connect 757 to 756
237	Clutch latch screw	759	Thread pull-off slide block
245	Gauge screw	760	Screw to connect 759 to 730 shuttle race
271	Presser bar lifter washer	761	Upper shaft
279	Needle bar bushing	762	Take-up cam
280	Needle screw and clamp	763	Feed cam and 702 screw assembly
281	Needle screw nut	764	Screw to go in rear end of 761
322	Bobbin winder rubber	765	Forward bushing for upper shaft
334	Screw to adjust bobbin winder to wheel	766	Screw for fastening 765 and 767 in arm, and 782 to 369
335	Spring for 334 screw. (Cannot furnish)	767	Rear bushing for upper shaft
341	Washer used when fastening 727 to 725	770	Needle plate
342	Attachment holder, complete	771	Screw for 770 needle plate
343	Presser foot	772	Bobbin winder, complete
345	Hemmer	775	Presser bar
347	Presser bar lifter and tension release cam	776	Presser bar cap
348	Presser bar lifter screw	777	Needle bar cap
357	Tension disc	778	Presser bar spring
358	Tension spring on inside of face	779	Presser bar lifter block assembly
358-A	Pin for tension spring 358 and 2005	780	Presser bar guide
359	Screw and nut to connect 358 and 785		Needle bar link
360	Guide pin in slot of tension plate	782	Needle bar block and screw assembly
363	Screw to adjust lower end of face plate		Screw to connect 800 to 762 (801)
364	Set screw	785	Tension plate
366	Thread cutter, complete	69786	Auxiliary spring
369	Needle bar, complete	69775	Adjusting washer for 69786
448	Washer for take-up rivet	789	Screw to connect 839 to 17229
36	Nut for 758 screw	792	Spring for 839 latch
34	Screw to fasten 767 in arm	793	Take-up cover plate (Cannot furnish)
548	Foot gatherer	795	Rear spool standard assembly
593	Stud for revolving spool standard	796	Rear cover plate (Order No. 9012 and 9013)
594	Sleeve for revolving spool standard	804	Screw to clamp 730 and rear bearing of 9975 shuttle shaft
701	Screw to bind 784 in 762	807	Gauge
702	Screw to fasten 763 and locate 762		Shuttle shaft and driver (9975)
703	Screw to tighten 762 on shaft 761 and fasten 842 in arm	809	Screw to adjust 69786 auxiliary spring
704	Screw to fasten 751 in arm	821	Washer on 69786 auxiliary spring
705	Center for feed rock shaft 724 and thread pull-off rock shaft 756	822	Washer under 839 latch
706	Nut for 705 and 797	823	Stud for lower end of main connection
707	Screw to connect 714 with 723, 754 with 756 and fasten bobbin winder to arm	824	Screw to fasten 746 crank on 808 shuttle shaft
708	Nut for 707 and 721 screws	830	Hand hole cover, complete
710	Pin in 711	17229	Shuttle race cover assembly
711	Shifting block	9861	Shuttle
714	Feed connection	836	Bobbin case complete with spring
715	Feed connection link	837	Bobbin case tension spring
716	Pin for 715	838	Bobbin case tension screw
717	Stitch adjusting lever	839	Latch to retain bobbin case
718	Stitch adjusting stud	841	Feed fork and stud complete
719	Friction washer for 717	842	Bearing for 841 feed fork and stud assembly
720	Sleeve for 718	843	Screw for end of 841 assembly
721	Screw to connect 715 to 717	852	Screw to fasten 885 clutch to upper shaft
722	Stitch indicator plate	861	Bobbin winder complete for rotary hand machine
723	Rock arm on rear end of 724	9622	Bobbin winder center for 861 assembly
724	Feed rock shaft	790	Take-up lever assembly
725	Feed bar assembly	885	Clutch ring assembly
726	Centers for 725 feed bar	886	Clutch latch spring
727	Feed	887	Clutch latch for 885 assembly
728	Screw to fasten 727 to 725	894	Dowel pin for timing
729	Spring washer for bobbin winder	1559	Bobbin winder pulley
730	Shuttle race assembly	20	Check spring assembly
731	Latch to hold 834 on 730	6067	Thread check
732	Spring on 731	6077	Feed connection assembly
	Pin for 731	6189	Screw to fasten arm to bed
	Spring pin to hold 834 on 730	6267	Bobbin winder pulley
733	Spring for 734	6540	Hinge nut
738	Thread guide plate on 834	9110	Tension indicator assembly
739	Screw to fasten 738 to 834	9144	Head hinge
744	Bobbin	9156	Head hinge

Upper tension assembly.

The upper tension assembly on the FR White is part internal, part external and unlike assemblies already covered, contains a control dial away from the tension components.

External components on the face plate consist of the main tension frame, check spring, check spring adjusting gear and screw and finally, tension adjusting screw.

The tension control dial or lever, whichever the case may be, faces the operator.

Internal components consist of a tension disc, tension adjusting spring and retaining screws.

Adjustment range on the FR White is from 1 to 8. 1 is for loose tension and 8 is for maximum top tension.

When the machine is serviced and upper tension set for user, always leave dial set on 2. This setting gives the user some adjustment for a loose stitch and a wide adjustment to compensate for normal wear.

If a tight setting to extreme of 8 fails to correct stitch, the adjustment is made on the external tension adjusting screw on face plate.

Grind a notch in a tension screwdriver until it's forked.

Set tension dial on 2, adjust small screw(a, figure 58), clockwise as need arises.

If 2 setting is too tight, turn screw(a) counterclockwise until corrected.

Caution: Before changing the adjustment, check bobbin case tension. It should be properly adjusted before changing upper setting. See page 69 for bobbin case adjustment.

Figure 58 illustrates external tension assembly, adjustment dial and proper threading chart for FR White, Kenmore and Domestic.

Figure 58



Figure 59



When maximum adjustment of the screw fails to correct tension setting, the face plate must be removed. Correction will be internal.

The White tension disc is thin embossed metal, not nearly as durable as external discs such as those found on Singer and imported machines, consequently it thread cuts much easier.

When maximum adjustment fails, or tension will not maintain tension setting, either the disc is badly thread cut, or the tension spring assembly has slipped from the pin.

To repair, the face plate assembly must be removed.

There are two set screws holding the face plate assembly to the machine. They're located on back side of face plate, one above and one below the arm. Raise presser foot.

Remove needle, loosen both screws and remove the face plate assembly.

Loosen small screws and remove tension dial.

Drop presser bar and pull the tension assembly from face plate.

Tension spring must be removed from position pin inside face plate.

Caution: Don't stretch or break the check spring during removal.

Position square end of adjusting nut into square cut hole on tension spring and loosen adjusting screw with forked screwdriver. Remove components and place on workbench in order of removal.

If tension disc is thread cut, replace with embossed side of disc toward tension frame.

Insert screw, replace tension spring with bow toward tension frame, and replace square nut, with square end down toward spring.

Tighten screw one or two turns. Replace assembly.

Slip tension frame end over pin under presser bar lifter. Insert spring in hole of face plate and adjust check spring in proper position above release pin, before placing tension spring over position pin inside the face plate.

Set tension dial on 1 and replace it on face plate. Small numbers go up. With tension dial set on 1 and tension spring adjusting screw barely tight, the eccentric control cam should slip over tension spring with ease. After dial is screwed in place, set it on 8 and tighten adjusting screw with forked screwdriver.

Thread machine and pull thread through tension. If proper drag is present, reset dial at 2 and replace face assembly on machine.

To replace face plate, turn balance wheel until link on main cam is at its highest point. (Link is screwed on older models, on models 41, 43, 77, the link is removable).

Hold face plate assembly in left hand and needle bar in right. Line needle bar until stud is directly opposite lower opening of link.

Reassemble.

Turn balance wheel while holding face plate in position to make sure the parts have meshed. If the needle bar moves up and down without binding, the assembly is correct.

Replace set screws and snug tighten.

If you've followed instructions and placed parts in order of their removal you know the long screw goes on top and the short screw on the bottom.

In this case we'll assume the needle bar is correctly positioned in needle hole. Position adjustment will be covered in depth later.

Test sew and adjust as needed.

Check spring.

The White check spring operates much the same as other machines. It's primary function is thread control. Tension control is secondary.

There are repairmen who state that the check spring has nothing to do with tension control. The fallacy is readily apparent when the spring is broken. Some power machines are set with little tension and a powerful check spring and operate very effeciently.

The check spring is set behind the tension frame with its head protruding just enough to allow upper thread entry when the tension is threaded.

To adjust, loosen black set screw and turn knurled gear.

If check spring is too weak, turn gear clockwise. Too tight, reverse the procedure.

Tighten set screw and test sew. Adjust as needed.

To replace broken spring, remove face plate and follow procedure outlined in tension disc replacement.

After tension frame is removed, loosen black screw and remove broken spring.

In replacing, small finger of spring goes down, into notch of knurled gear. Tighten set screw and test for tension. Spring should drop onto stop with a feel of authority. Follow steps outlined in previous text for adjustment.

The experienced repairman can replace the check spring without removing the face plate, but it's unwise for the novice or user to try.

Caution: When adjusting the check spring, always keep presser foot down.

When the face assembly is removed from machine, it's a good idea to oil and clean component parts thoroughly.

Use a lint-free cloth saturated with cleaning solvent.

Always use a top grade household oil when lubricating your machine.

Service tip: When threading the machine, always pull thread upward to bring it into tension and check spring.

When machine is properly threaded, a small clicking sound will be heard.

Lower tension-shuttle race assembly.

Components of lower stitch forming assembly consists of bobbin, bobbin case, shuttle, race and race cover.

Figure 60

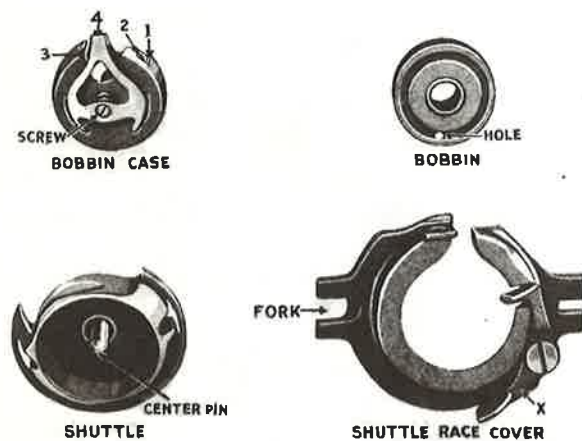
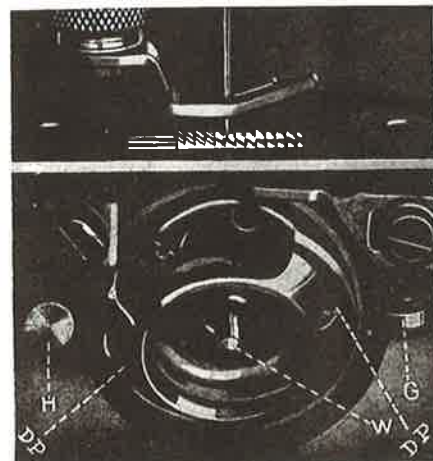

Figure 61



The wound bobbin is placed in bobbin case, thread is slipped into slot one and two, around slot 3 and out under tension spring 4.

To adjust lower tension, adjust small screw in center of bobbin case. Tension should be compatible with number 2 setting of upper tension.

If lower tension is too loose, turn adjusting screw clockwise as needed, if too tight, reverse procedure. Adjust and test sew.

If adjustment doesn't hold, remove adjusting screw and tension spring. Check the spring and bobbin case for thread cuts. If thread cut, replace.

When adjusting screw doesn't hold a setting, remove and spread with a tension screwdriver. Use extreme caution.

Put a drop of oil on shuttle spindle and replace bobbin case. Test sew and adjust as needed.

When a White owner complains of a loud screeching sound on her machine, nine times out of ten a drop of oil on shuttle spindle will solve the problem.

To service sewing mechanism, remove race cover by depressing lever (G), figure 61, and slipping fork away from button(H).

After components have been removed, brush out the area with stiff bristled brush. Invariably, bits of thread and lint will be found in race area.

Put a drop of oil in raceway(track shuttle rides in).

Replace components.

Shuttle goes in race with center pin(W) out. The two holes fit over retaining pins in driver. The point of the shuttle goes on over the arrow stamped in brass shuttle driver.

If shuttle is replaced incorrectly, the machine will not sew.

Later model White machines have a revised driver and the shuttle will not go in backwards.

Race cover goes in place with fork over button(H) and clips in place on lever(G). Bobbin case snaps in place with neck pointing up. Bobbin case must seat properly on shuttle spindle.

Check the shuttle carefully. Inspect shuttle point and the slotted area below it. If the part shows signs of excessive needle strikes, smooth it with emery paper, but if the point is broken or slotted area is too badly scarred, replace the shuttle.

Check inner race cover for damage. Needle strikes may be found near top of part. If the upper thread hangs up continually, check this part.

Bobbin case retainer lever(x) consists of lever, set screw and spring. If the lever tip becomes bent, thread will catch and hang up. Bend the lever until inner tip is level with race cover.

If the spring is lost or broken, replace it. A missing spring will cause an erratic action of the lever and result in faulty stitching.

When replacing spring, snug tighten set screw. The lever must move freely.

The FR model contains a thread throw-off which aids in stitch formation. It works off the feed bar and aids take-up arm and check spring by holding the thread taut until both threads start upward to complete the stitch.

Thread throw-off is prone to bending. To straighten, remove the needle plate and adjust as needed. The part should be parallel to feed dog with the slotted raceway working freely over collared screw(L), figure 62, page 70.

Later model White and Domestic machines don't have this part since the thread throw-off is built in the shuttle.

New style White-Domestic machines also have a different bobbin case and race cover.

The bobbin case latches to the shuttle spindle thus eliminating the latch on the race cover. Tension adjustment is on side of case although tension adjustment is the same. Clockwise for more tension, counterclockwise for

less. The tension spring on new style bobbin case is much easier thread cut and should be checked frequently.

If the bobbin case will not stay in machine, check shuttle spindle. Small bits of thread have a habit of forming in the groove where bobbin case locks in place.

Figure 62

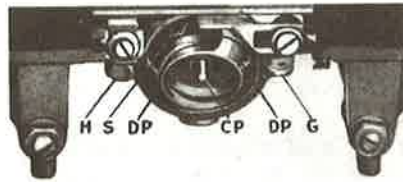

Shuttle Driver-lower drive assembly.

The lower drive shaft is pinned to a slide bearing and block. Connector is attached to upper main shaft somewhat the same as a connecting rod on a auto motor.

It's split at the top and fits over the main shaft. The adjusting screw is accessible through a hole cut in rear of machine arm.

The rod has a pinned slide block at lower end which works back and forth in a bearing attached to lower driver shaft.

The drive shaft is pinned to the slide bearing and held firmly in place by a set screw. The machine is timed and pinned at the factory. Only in very rare cases will a pin break and cause machine to jump time.

If the pin breaks, turn driver slowly until pin holes of driver and bearing are aligned. The hole is drilled off-center and when properly pinned, machine is automatically timed.

If machine develops a rattle and driver assembly appears loose, tighten set screw on connecting rod. Turn balance wheel until screw is visible through hole in rear cast. Tighten screw until rattle disappears. Don't over-adjust. If machine binds after adjustment, loosen screw slightly.

Figure 63 illustrates components of shuttle and drive.

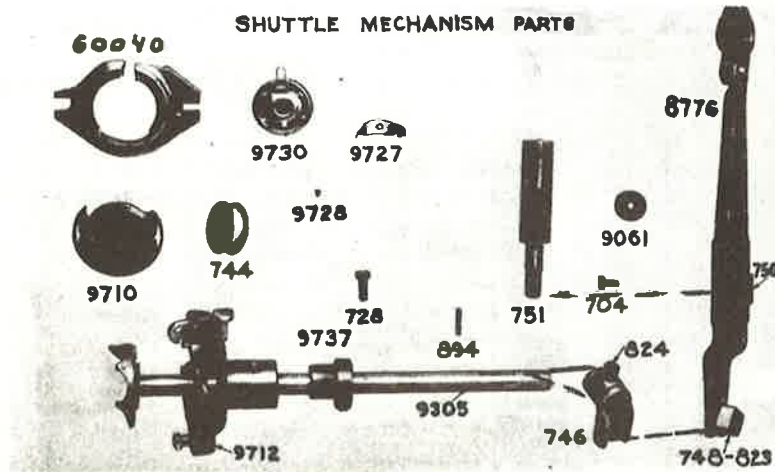

Tension Adjustment.

Now that both upper and lower tension and related components have been covered, the next three pages will illustrate their relationship, how to adjust each, and what to look for when they malfunction.

Figure 64 illustrates improper stitch with upper thread pulling lower thread through the material.

Probable cause:

1. Upper tension too tight.
2. Lower tension too loose.
3. Bobbin case malfunction.
4. Improper check spring adjustment.
5. Thread throw-off malfunction.

Correction:

1. Turn tension dial toward a smaller number, or correct adjusting screw with forked screwdriver. See page 66.
2. Remove bobbin case, tighten adjusting screw clockwise as needed.
3. Check bobbin case, if spring is thread cut, replace it. Remove adjusting screw and spread with tension screwdriver. (old style only). If maximum adjustment fails to produce tension, replace bobbin case.
4. Refer to page 68 for adjustment.
5. Refer to page 69 for adjustment.

Figure 64

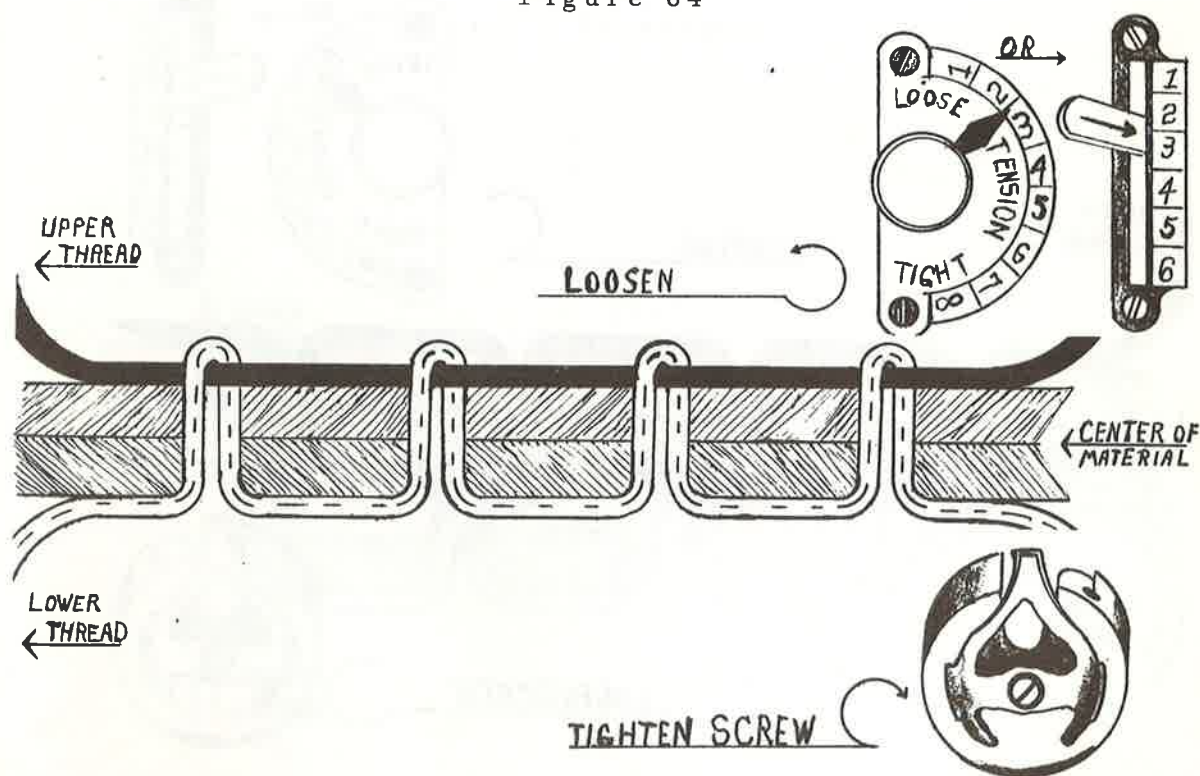

Figure 65 illustrates sample stitch where lower thread is pulling upper thread down through material, or the upper thread is hanging up due to a malfunction in the lower sewing mechanism.

Probable cause:

1. Upper tension too loose.
2. Lower tension too tight.
3. Bobbin case inserted incorrectly.
4. Broken or needle scarred shuttle.
5. Broken driver.
6. Accumulation of lint, dirt or thread in race assembly.
7. Thread throw-off malfunction.

Correction:

1. Turn dial or lever toward larger number as needed. If extreme adjustment is required, make adjustment at adjusting screw, with forked screwdriver. Refer to page 66.
2. Loosen adjusting screw on bobbin case as needed.
3. Check lever on race cover (FR model). If lever is sticking, replace spring, loosen set screw, or straighten lever as needed.
4. Refer to page 69. If shuttle is broken or damaged beyond repair, replace it.
5. Brass driver may be bent. Straighten pins as needed. See page 70.
6. Remove components and clean race assembly thoroughly.
7. Refer to page 69.

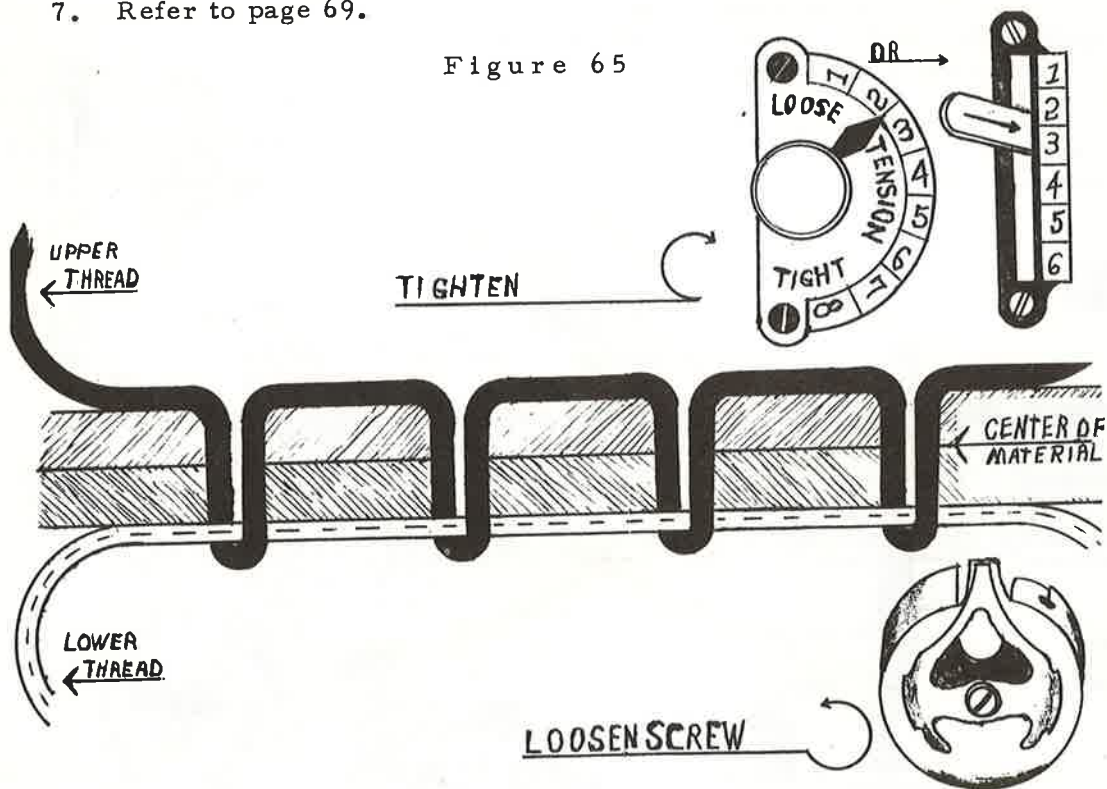

Figure 66 illustrates what a good stitch should look like. Both threads are locking in the center in correlation with the material. A good stitch looks equally uniform from top or bottom.

Always use proper needle for size thread and material being sewn.

Needle chart in front of book should help the novice determine correct size.

When test sewing, always use new material. Material that has been laundered loses much of it's body and is not a good criteria for test sewing. The cloth will look like it was sewn with a dull needle and stitch will appear ragged.

The repairman should buy a roll of demonstration material and a spool of 50 white thread, before attempting a service call.

Although most of the diagrams in this chapter show the FR White, the principles apply to all White, as well as their contract brand machines.

Relate the steps to machine in question. Follow steps outlined in the book and your problem will be solved.

Service tip: Start each tension adjustment with a new needle and different bobbin. Many times a bobbin will be bent or slightly scarred, but enough to distort the tension and the novice repairman will spend countless hours searching for a phantom.

Never overwind a bobbin. Too much thread on a bobbin will create a slight drag and change bobbin case tension completely.

Figure 66

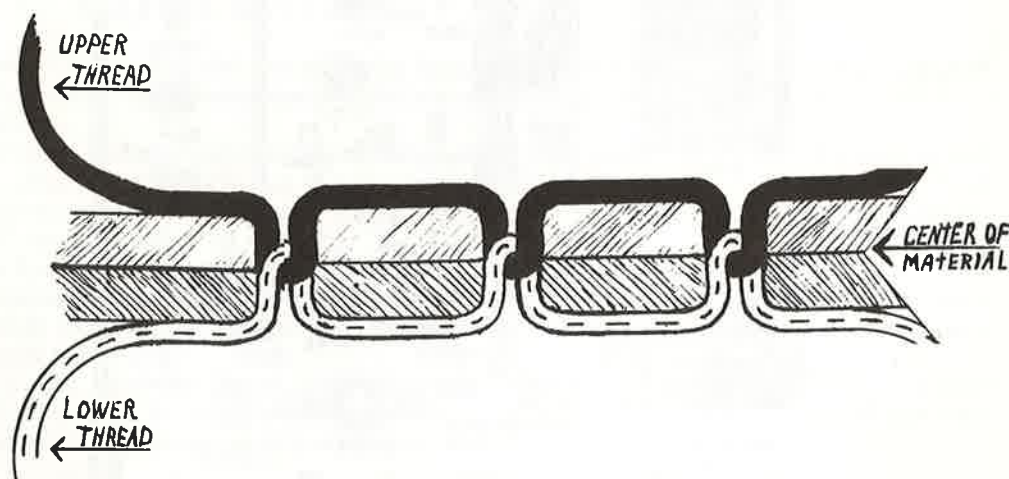

Needle bar.

The needle bar on a White Rotary is unique in sewing machines because it can be adjusted to conform with lower sewing mechanism, and if not positioned in lower right corner of the needle hole, the machine will skip stitches.

The adjustment referred to is not a timing adjustment, i. e. up and down but rather a side to side adjustment.

To adjust on the White FR through 43 series, comparable Domestic and Kenmore machines, loosen both screws holding face plate to machine arm.

Use a tension screwdriver, insert in screw hole directly below tension frame.

Lower needle into needle hole and observe position.

Move face plate assembly forward until needle is in front of needle hole.

Snug tighten both set screws. Turn tension screwdriver until needle sets in lower right hand corner of needle hole.

If the needle is outside needle hole, re-position face plate assembly until needle enters hole. Follow instructions in previous text.

Tighten set screws and test sew.

The face plate assembly on the 77 White is a self contained unit, but is separate from the face plate cover. See Fig. 67 below.

To adjust needle bar, remove face plate cover.

Loosen set screw at top and bottom of face assembly unit.

Lower needle into needle hole, remove face plate tension unit.

If needle must be moved to right hand corner, adjusting screw is in upper right hand corner of assembly.

Adjust screw as needed, using a tension screwdriver.

Tighten all screws, replace face plate cover and test sew.

The needle bar is timed and set at factory. Timing is very rare.

Check needle clamp occasionally. Remove from needle bar and clean.

Figure 67
FACE PARTS FOR SERIES 77 HEAD

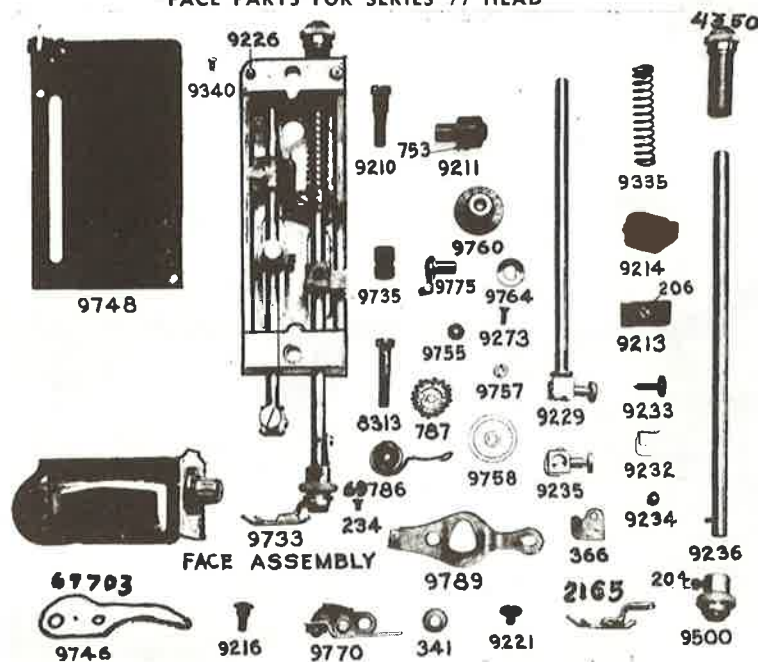

Presser bar.

The presser bar assembly is basically the same on all White machines whether FR or new style.

To adjust for proper clearance between presser foot and needle plate on a model 77, remove the face plate, tension assembly and face assembly.

Proper clearance is 1/4" between underside of foot and needle plate. After the face assembly has been removed, turn assembly over and loosen the set screw on presser bar lifter block (the lower of two blocks on presser bar). Lower or raise presser bar as needed.

Tighten set screw, replace all components and test sew.

Upper block on presser bar regulates the amount of spring pressure. If spring becomes weak, or too strong, loosen screw and adjust as needed. Move block up for more pressure, down for less. If pressure is so great the automatic darning won't release enough to allow free movement of cloth, loosen pressure by lowering the block. See previous text.

The automatic darning operates much the same as on other machines except the button can't be adjusted for different pressures. When adjusting, turn the adjusting screw.

If the automatic button won't stay down, check the adjusting cap. A tiny pin holds the cap when it's depressed and turned. If pin is broken, replace with one of similar size.

The presser foot is attached without a thumb screw. A knurled knob can be turned up to release the foot. When turned down, it holds foot in place.

All external attachments are affixed in the same manner.

The presser bar lifter on FR and 41-43 models can be adjusted without removing the face plate assembly. At the rear of the face plate, directly over presser bar lifter, the adjusting screw for changing pressure is located.

On the FR it's a slotted screw. Later models have an allen screw.

Adjustment is similar. To increase spring tension for more pressure on presser foot, loosen screw and move adjusting block up. To decrease the pressure, reverse procedure.

Proper clearance is 1/4".

To adjust pressure, use adjusting cap. Down for more pressure, up for less. Some Domestic and Kenmore machines will have automatic darning.

For adjustment see text covering model 77.

Model 77 tension assembly.

The model 77 tension varies slightly from other tension assemblies. Instead of interior-exterior components, the assembly is unitized and fits on machine in one piece.

To service, remove assembly from lower face plate by removing two small screws. Place assembly on work bench with interior up. Turn tension dial to 0, loosen tension adjusting nut, remove spring (9789) and tension disc.

The 77 tension disc is smaller than other models.

Check for thread cuts and replace if needed.

To reassemble, replace tension disc, embossed side down, flat tension spring with pin down and flat end in notch of control dial. Replace adjusting nut and turn down.

Set tension dial at 2 and pull thread through tension assembly. "Feel" is very important in tension adjustment. If the thread feels like it has enough drag, replace assembly and test sew.

Always make adjustment before replacing assembly. Adjust tension dial when setting is close.

Check spring adjustment on the 77 is same as other models except it's attached in a different manner, however same adjustments apply.

See text on page 68 for check spring adjustment.

Figure 68

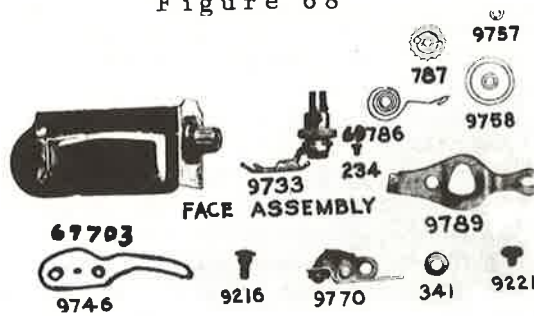

Take-up arm.

The take-up arm works off the main cam in an eccentric groove. As the machine runs, a roller cam on the take-up arm follows the groove around.

As the take-up arm goes up and down, in time with needle bar and the lower sewing mechanism.

Roller stud will often bind when a machine has been neglected. To service, remove cover plate and loosen large screw holding take-up arm in place.

If stud roller is frozen badly, place in a pan of solvent and let it soak for a period of time. If it won't turn freely after a good soaking and oiling, discard it, and replace with a new one.

Excessive wear will cause play in the arm. To determine extent of wear, turn balance wheel until arm is at highest point. Hold arm in left hand and balance wheel in right. If arm moves up and down more than 1/8", replace it.

The large screw that holds take-up arm in place is collared. The collar is adjustable. When you replace a take-up arm, if possible, replace the screw at same time.

When impossible to replace screw, put screw in take-up arm, turn over and tap collar until slightly below shoulder of take-up arm.

This will leave slight tolerance so arm may move freely.

If machine binds after take-up arm has been installed, remove the screw and adjust until machine no longer binds.

Figure 69
UPPER SHAFT AND TAKE-UP MECHANISM PARTS FOR SERIES 77 HEAD

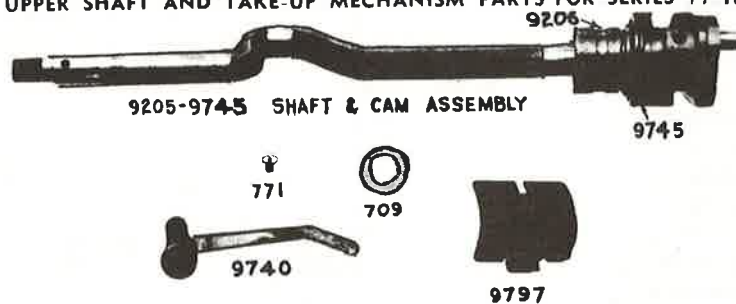

Feed assembly.

Figure 70 illustrates the feed system and stitch control lever for model 77 White. The feed system is basically the same as on older models and most adjustment and repair procedures are alike.

Lower feed assembly is activated by feed connection bar(9311). The assembly shown is model 77, however, the 41-43, Domestic and Kenmore models operate much the same.

The bar is forked at upper end and works off eccentric cam(763) which is attached to the upper main shaft.

Stitch adjustment assembly is tied in about a third of the way down the bar where stud(9346) goes through connecting bar.

The stitch control on model 77 is two dials(9780). One dial controls length of stitch forward, the other is a positive reverse control. The White 77 is one of very few machines with a positive reverse control.

The stitch control on FR model is forward only, however principle is the same.

Models 41 and 43 have a reverse lever, with an adjustment knob. When a lever is pulled over center, the machine sews in reverse. Knob adjusts the length of stitch.

Reverse control lever of this type is used for locking seams and mending since it isn't positive and reverse seam never appears as neat as forward seam.

Timing, adjusting and setting proper feed dog height are all serviced in same general manner.

Feed connecting bar attaches to lower feed system(9703) with eccentric screw and nut(707-708).

The feed dog is attached to feed raising bar(9903), which works off a cam on the lower drive shaft, in perfect time with the lower sewing mechanism.

The feed system can be timed two different ways. If throw of feed is too extreme and feed dog strikes needle plate, timing is done on feed rock shaft at junction with connecting bar.

Set stitch control lever on 0, loosen nut(708), turn eccentric screw(707) and observe feed dog in raised position. Adjust screw until feed dog rises and falls in same place.

Snug tighten lock screw while holding eccentric screw in place. Test sew and adjust as needed. When correct position is attained, tighten lock nut.

Second timing is feed motion in relation to stitch formation. Timing at this point is readily apparent when feed dog moves material while needle is in it.

Loosen set screw on feed raising cam. Turn balance wheel until needle is at highest point.

Move cam forward until feed is raised to maximum height. Tighten set screw and test sew.

To adjust feed rock shaft for end play, loosen lock nuts(706) located at each end of shaft.

Turn balance wheel until feed dog is in needle plate slots.

Tighten tapered screws, clockwise, until shaft is snug. Tighten lock nuts and test. Observe feed dog in needle plate. When it's centered properly, tighten lock nuts securely and test sew.

If machine binds after adjustment has been made, loosen lock nuts and back tapered screws off slightly. Adjust until machine runs freely.

The feed dog on a White machine can be adjusted to compensate for wear. The shank is slotted for adjustment.

Correct setting for general sewing is 1/32" above surface of needle plate.

To adjust, tilt machine head back. Loosen set screw which is located over shuttle mechanism, directly above pin(H) figure 62.

Pry feed dog loose with care. Adjust as needed. If machine doesn't feed, move feed dog up to proper height. If feed dog is too high and jerks material instead of feeding it smoothly, move feed dog down.

Tighten set screw, replace head and test sew.

Check feed dog for proper centering and if adjustment is needed, refer to text on page 77.

Figure 70

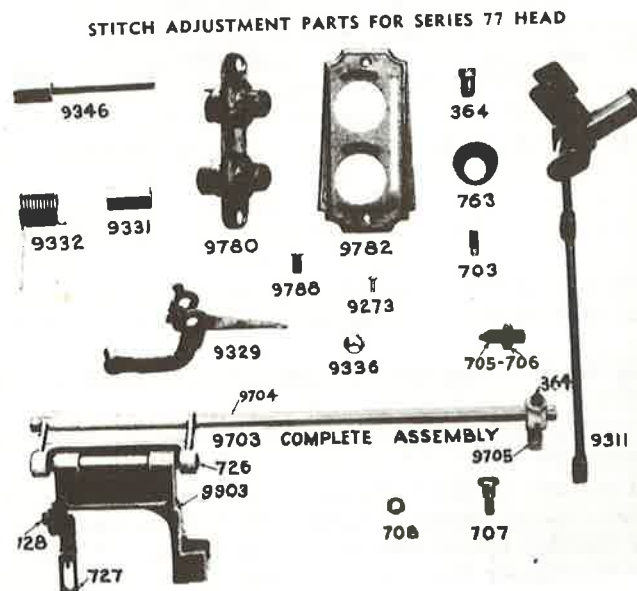

Needle plate.

The American made White probably has the most positive feed set-up in the industry. It's constructed with feed teeth on all four sides of the needle. The needle plate should be removed and area under it cleaned thoroughly on every service call. If user, clean once a month.

To remove, loosen both screws and lift off.

If needle hole is badly scarred, replace with a new plate. If slightly damaged, smooth with emery cord. Don't enlarge needle hole.

If narrow strips of metal between teeth are bent, replace the plate.

Figure 71
FR thru 43

Figure 72
Model 77

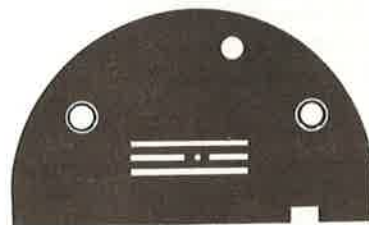
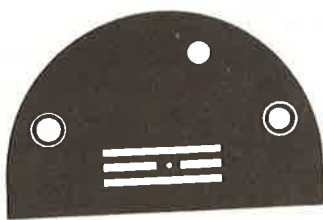

Throat plates.

Figure 73 shows throat plate for FR through 43 series White.

Figure 74 shows throat plate for 75-77 series White and later model Kenmore and Domestic models.

Figure 73

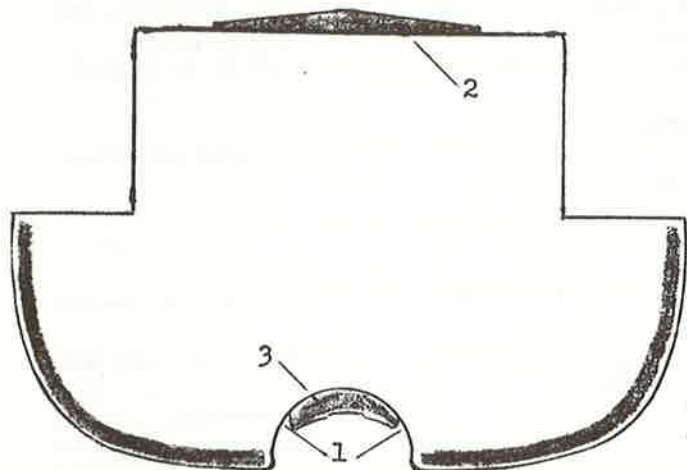
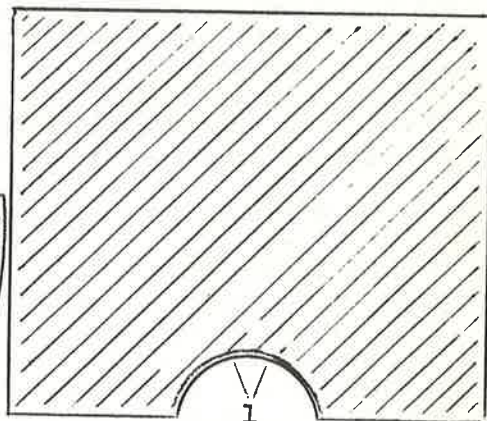

Figure 74



Balance Wheel(hand wheel) and clutch assembly.

The balance wheel on the FR is spoked with a slightly different clutch arrangement than other machines.

Balance wheel goes on shaft, followed by a collar with a lever pinned in slot.

The collar is attached to the main shaft by two tapered screws which fit into corresponding slots on shaft. A large screw fits over end of shaft.

To release clutch, pull lever back. Wheel will turn as machine stays inert.

Figure 75

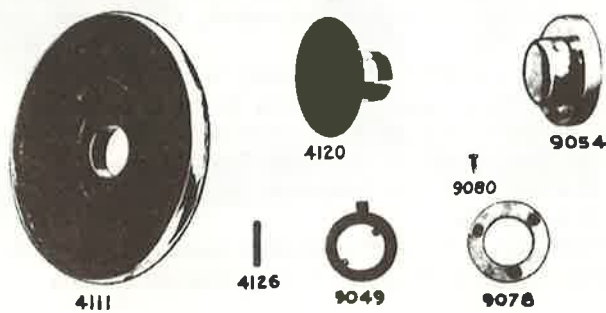

Collar(4120) is pinned to main shaft by pin(4126). The clutch washer(9049), fits on shaft with inverted fingers pointing in.

The washer with bearings(9078) slips next to clutch and release knob(9084) screws on over other components. Screw(9080) acts as stop screw when the clutch is released.

When knob is released, stop screw rests against clutch washer as washer moves away from balance wheel, allowing it to run free.

When knob is tightened, components press against balance wheel and the pressure activates the machine.

If user complains that machine jumps out of gear constantly, remove the knob and bearing washer. Remove clutch washer and turn 180 degrees.

If machine will not release, i. e. runs all the time when clutch is activated, make same adjustment.

Replace components and test sew.

Don't force adjusting knob against components or washer with bearings will break and clutch won't release.

Bobbin Winder assembly.

The FR bobbin winder is a simple affair. On treadle machines it's simply a pulley with spindle for attaching the bobbin.

To activate, the pulley is pushed upward against treadle belt. As pulley turns, spindle turns bobbin and fills bobbin with thread.

If winder binds, loosen with cleaning solvent, then oil thoroughly.

FR electric machines use the same system except a rubber ring rides on balance wheel. The winder doesn't have an automatic shut-off so operator must be observant.

Self locking screw is turned inward to hold rubber ring against wheel.

Later model White machines have an automatic shutoff. See figure 76.

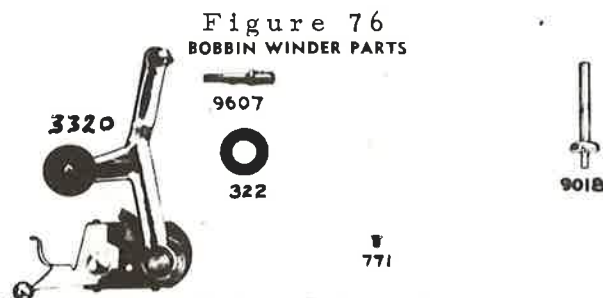

To wind on later model, pull thread through small tension at top of bobbin winder. When control lever is activated, the end slips into bobbin and acts not only as guide for uniform winding, but shut-off lever as well.

The winder is on a spring and when activated, it presses winder rubber against balance wheel.

As the bobbin fills, the lever backs away until bobbin fills. It then drops down, bringing the rubber ring away from balance wheel.

If guide becomes bent, use a pair of needle nose pliers(cushion with cloth to prevent damage to part) and straighten the guide.

Put a bobbin on the spindle and activate guide. Determine which direction correction must be made.

Bend guide accordingly. Test frequently until corrected.

Replace the rubber winder ring on every service call.

Oil thoroughly.

A sloppily wound bobbin will create many sewing problems.

Chapter Five

Manual Zig Zag Sewing Machine

The manual zig zag machine can be broken down into two different categories. The single needle position, and the three needle position type. There are a few two needle position machines on the market, but not enough to describe in depth.

Single needle position machines are generally low, budget priced models. They have more sewing features than the straight stitch, but less than the super automatic.

The sewing mechanism is generally a modification of the class 15, although a few are rotary action, and at least one is a long shuttle.

Three needle position zig zag machines are mostly of European origin. They are responsible for the acceptance of imported machines by the U.S. housewife.

There are a number of Japanese, three needle position machines sold in the United States, but since most utilize the class 15 system, this chapter will deal with the single needle position machine, and refer to the three needle position when there is a distinct difference.

European three needle position manual zig zag machines sold in the U. S. include, Necchi, Pfaff, Viking, Calanda, Anker, Adler, Bernina and Borletti. Most of these machines will be covered in chapter six, since many of the automatic versions utilize the same stitch forming mechanism.

Typical Manual Zig Zag- Single Needle Position.

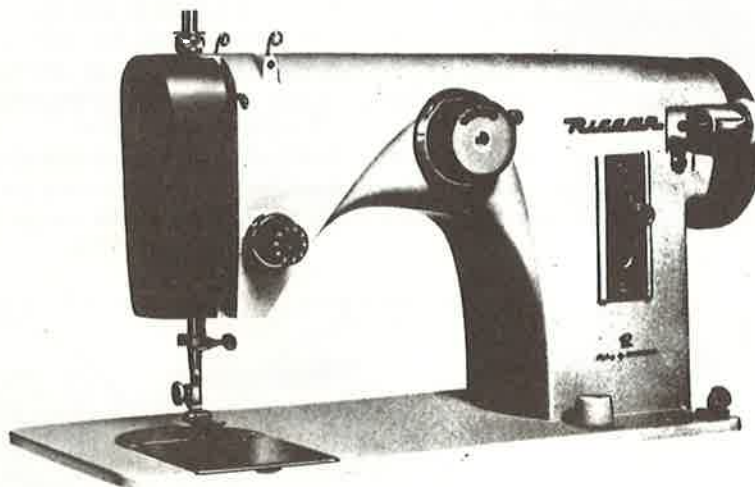

Upper tension assembly.

The tension assembly on the single needle, manual zig zag machine is basically the same as the Class 15.

Tension adjustment and components are the same whether machine has a conventional front tension assembly.

Figure 80

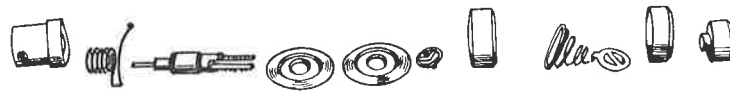

The assembly is unitized with check spring enclosed and inserted into the head.

To adjust the tension, turn clockwise for more tension, counterclockwise for less.

To adjust the check spring, remove tension assembly. Loosen set screw on tension barrel and turn tension stud until spring has proper drag.

Check spring must release the thread as needle enters material. If the check spring is too tight, turn the stud clockwise until corrected. If too loose, reverse the procedure.

Tighten set screw and replace tension assembly in head. Check spring, to the left if a side tension, to the right if conventional type tension.

Lower tension assembly.

The sewing mechanism is Class 15, whether conventional or transverse hook arrangement. Example of transverse hook is shown in figure 85, page 86.

Components are basically alike except assembly faces front of machine.

As you've probably discovered, the components are the same as Class 15 except in cases of manufacturers option regarding the style race cover and race assembly.

Three steps in proper threading of a Class 15 bobbin case.

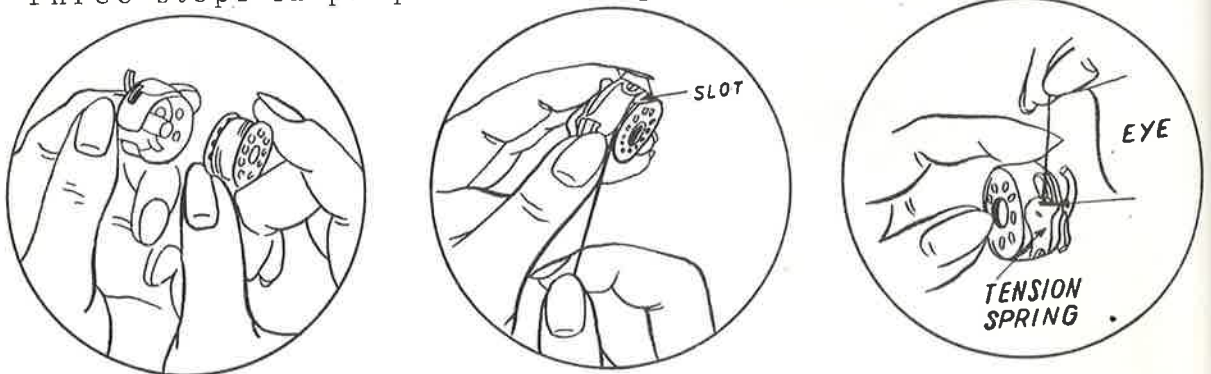

Before adjusting the lower tension, be sure machine is properly threaded in upper tension.

Figure 82 illustrates correct threading procedure on machine with link take-up.

Thread goes into guide A, between tension discs B into check spring C, under thread guide D, into take-up arm E, from front to back, down into both guides F & G, into needle clamp guide H and into needle eye, from front to back if transverse hook. From left to right if conventional hook.

After the machine has been properly threaded, and top tension adjusted, the lower tension can be adjusted.

The bobbin case consists of the body latch, spring and adjusting screw.

To adjust, remove bobbin case from hook, see figure 84.

Use tension screwdriver and adjust as needed.

If upper thread pulls down, loosen lower tension by turning adjusting the screw counterclockwise.

If lower thread pulls up, tighten the lower tension.

Figure 83 illustrates bobbin case, showing adjusting screw.

Replace bobbin case in machine and test sew.

If bobbin case will not hold tension, remove adjusting screw and inspect the spring. If thread cut, replace.

If adjusting screw is stripped, replace with a new one.

For further adjustment procedures, refer to Chapter Two, page 40, 41 and 42.

Figure 82

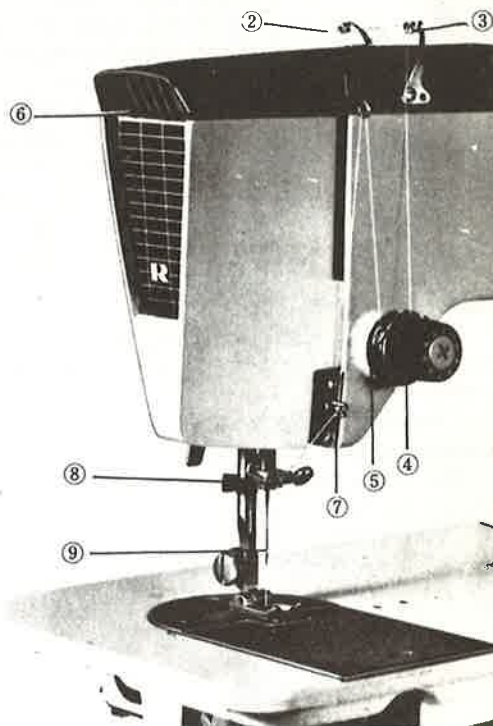

Figure 84

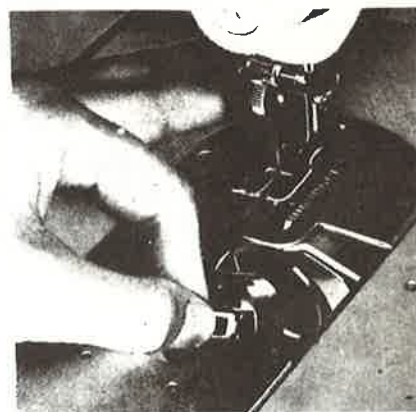
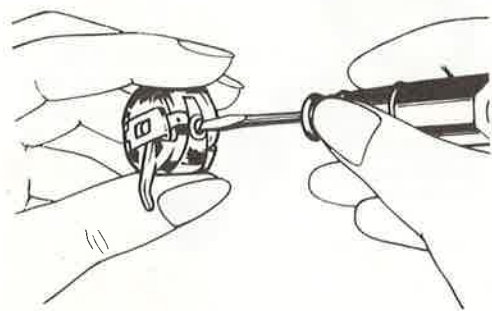

Figure 83



case.



The only real difference between the straight stitch and zig zag with Class 15 sewing mechanism is the oscillating driver on the zig zag. The driver, moves back and forth when the zig zag lever is activated.

This is accomplished with the addition of a slide block on the oscillating crank. When the zig zag lever is activated, the slide block moves with the driver in the oscillating crank.

The connecting link, in addition to tying into the upper main shaft, also ties into zig zag lever in the upper arm.

When the lever, or dial on later models, is activated, all components are timed and work together in smooth coordination to create the zig zag stitch.

Timing and regulating the zig zag machine is generally done in the upper arm, either at the needle bar frame or the zig zag mechanism.

Figure 85 illustrates basic components of the lower sewing mechanism and their relation to each other.

If shuttle hook is damaged, or the point is broken, it should be replaced. Severe needle strikes can cause a lot of damage and impair the sewing process.

The hook can be repaired if damage isn't too severe. Use a good grade of emery cloth and smooth the part in slow, easy stages.

Be sure the gears are greased frequently. Use clear vasoline if nothing, clear grease in particular, is available.

Check the race cover(2120) for needle strikes on upper portion. If damaged, remove the part and replace with a new one.

Figure 85

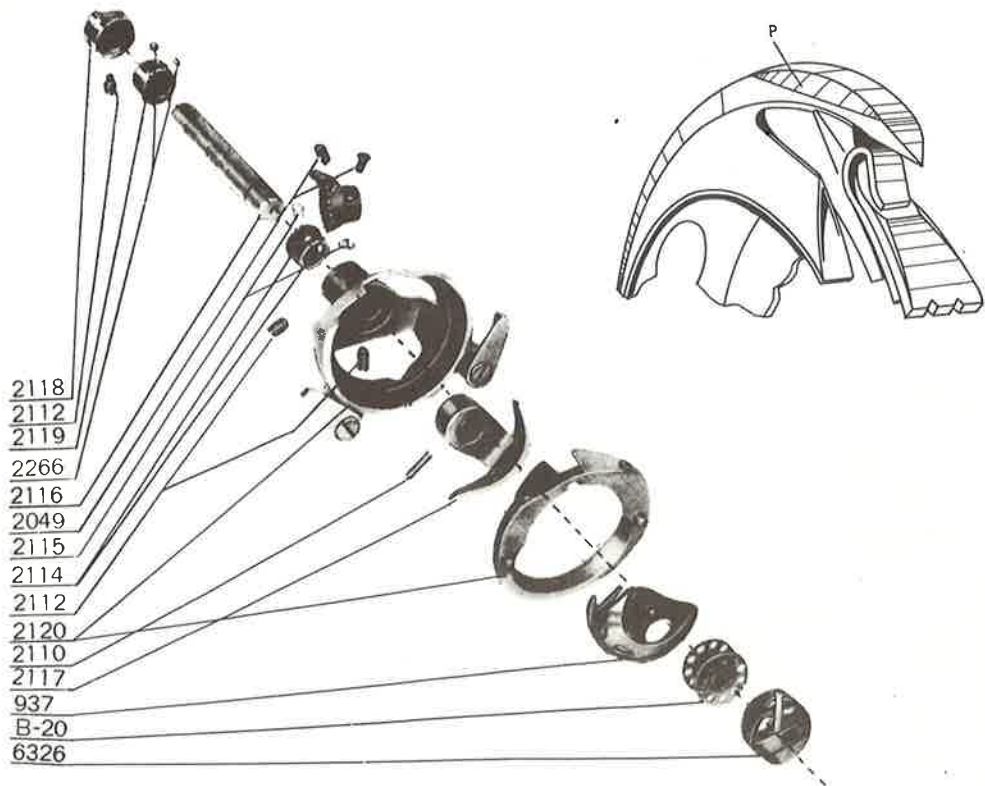

Zig Zag Assembly

The zig zag assembly of the Riccar RZ-204B is typical of most manual zig zag machines in their line. The unit is composed of a cam and block, regulated by the zig zag width regulating knob. The zig zag cam shaft contains a gear which meshes with a gear on the main shaft. When the machine is activated, the main shaft turns, and meshes with the gear on the cam. The cam moves on the block as the operator changes from straight stitch to zig zag. Figure 86.

Figure 86

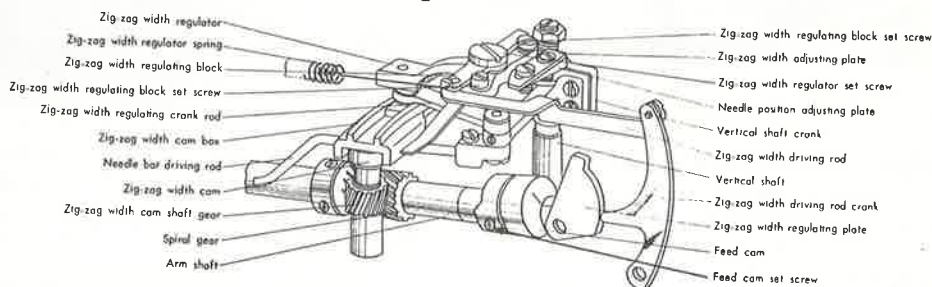

The zig zag width regulator is governed by a regulator set screw at the center of the movement. When the zig zag crank rod is at dead center in the width cam box, and width regulator is against the needle position adjusting plate, the machine sews straight stitches.

As the adjusting lever, or dial, is moved, the zig zag width regulating plate pushes the width driving rod crank. The rod moves the regulating block, which moves the regulator on the cam block.

As the width regulator moves, the width regulating crank moves over center from the cam block, and makes a motion following the movement of the cam block, forming the motion for a zig zag stitch.

Figure 86a & b

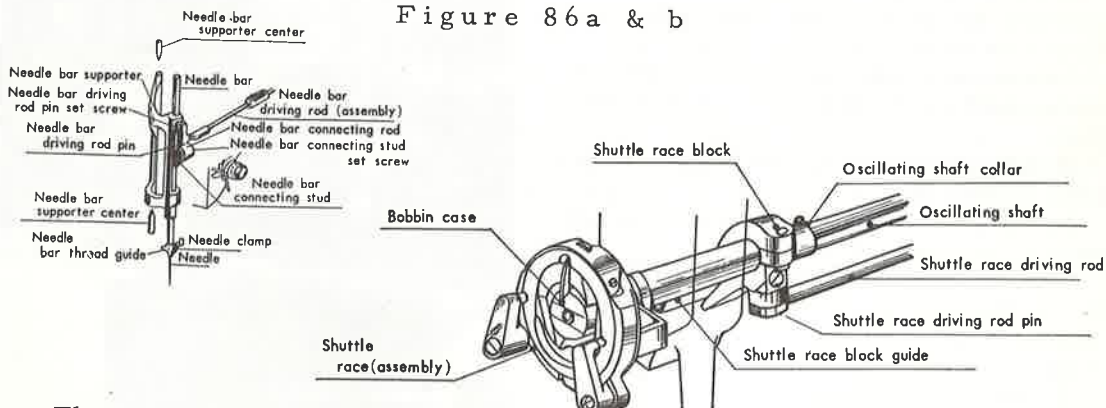

The needle bar moves by means of a driving rod, which is connected to the zig zag assembly, and in turn, is timed with shuttle movement by being connected to the driving (or connecting) rod that runs from the main shaft to the lower sewing mechanism. (figure 86a).

Lower assembly (figure 86b).

Timing

Figure 88, 88a, 88b

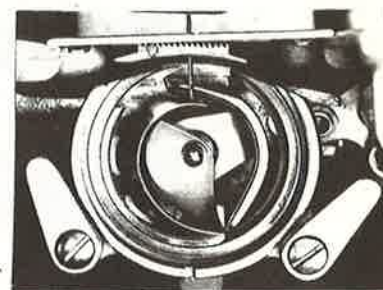
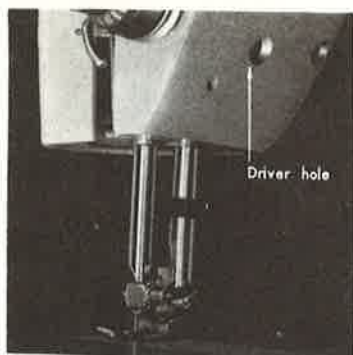

If the machine skips stitches, remove shuttle race cover, and bobbin case. Tilt machine head back, and set zig zag regulator knob on setting 0.

Thread machine, and turning balance wheel slowly, observe the needle travel, and its relation to the shuttle point when needle starts its upward travel.

Timing is incorrect if shuttle point doesn't pick up the upper thread.

To adjust, loosen set screw on needle bar, through driver hole (figure 88), and move needle bar until needle is in proper position.

Figure 88b shows proper position of needle in relation to shuttle point, at lowest point of needle bar travel.

Tighten set screw, replace shuttle components, and test sew.

Figure 88a, shows position of needle bar at lowest position. Measurement between arrows should be about $25/64$ ".

The proper distance between eye of needle and point of hook, at position shown in figure 88b, is $3/32$ ".

Before timing a sewing machine, always start with a new needle, and be sure needle is properly inserted.

To adjust clearance between needle and point of hook, loosen shuttle race block screw, illustrated in figure 88c.

Proper clearance is $.004$ ". This is quite close, about the thickness of a piece of paper, doubled.

Move entire race assembly and observe. Remove needle plate.

Check needle position. Race assembly must not turn while this adjustment is being made. The needle must pass through center of slot.

Tighten set screw on race block, replace needle plate and test sew.

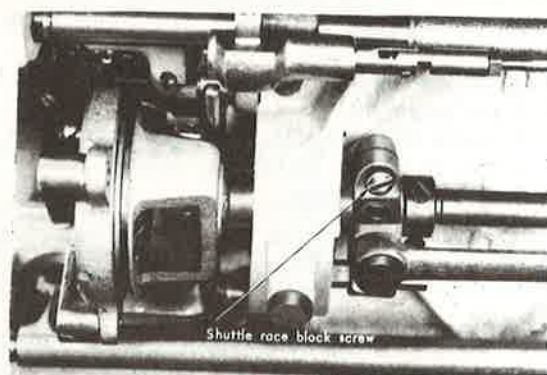

Relation of shuttle race upper spring and needle position

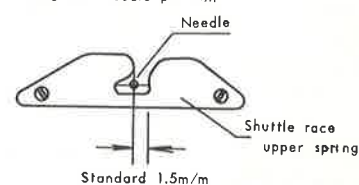
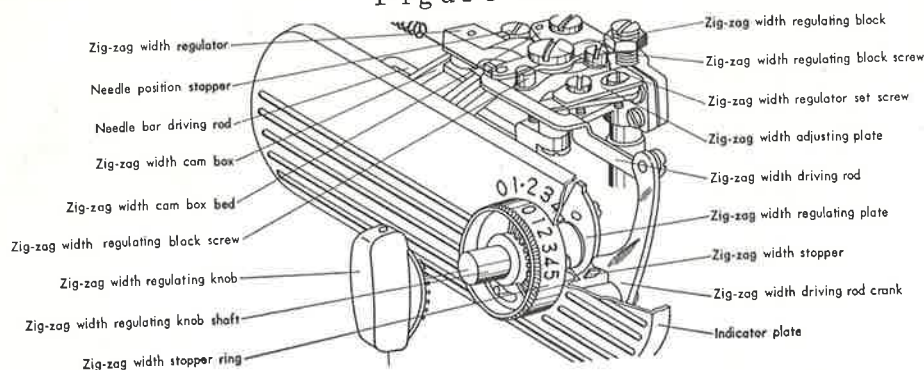

Figure 88c

Figure 86c



Adjusting the zig zag mechanism.

To adjust the zig zag width regulator, remove top cover on machine.

Turn balance wheel until cam is in extreme left of cam block(c, figure 87), then lower needle until it barely enters needle plate.

When zig zag regulator knob is moved, the needle shouldn't move. If it does, adjust as follows:

Loosen needle position stop set screw. (Screw will be found directly behind needle position stop screw(D, figure 87).

Screw(D) is eccentric. Turn screw(D) until needle ceases to move when regulator knob is moved from setting 0 to 5 and back again.

Tighten set screw securely.

Replace top cover, and test sew.

To adjust zig zag motion so needle enters needle hole in same position, left or right on zig zag setting 5, adjust as follows:

Set zig zag dial on 5.

Turn balance wheel, and observe direction adjustment must be made.

Loosen screw(E, Figure 87), on the main shaft gear, and move gear to adjust.

If adjustment is to the right, turn gear clockwise.

If adjustment is to the left, turn the gear counterclockwise.

The needle must start to swing and enter the needle hole at exactly the same place, on both left and right position.

To adjust needle swing, remove top.

Set regulator knob on 0. This adjustment is necessary when the needle swings(sews zig zag), on the straight stitch setting.

Loosen screw (A, figure 87a), and turn balance wheel. Move position plate until needle stops swinging on a 0 setting. Tighten screw(A).

After adjustment, move regulating knob to setting 5, and observe. If the zig zag width doesn't correspond with setting, loosen screw(B) and position zig zag width adjusting plate.

Figure 87

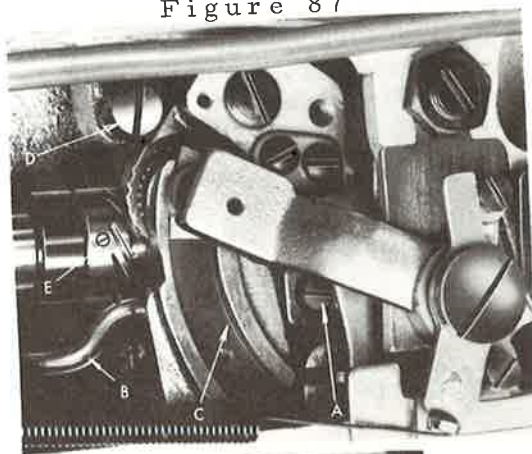

Timing

Figure 88, 88a, 88b

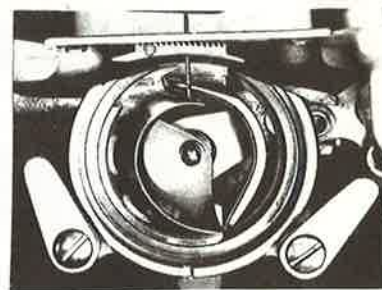

If the machine skips stitches, remove shuttle race cover, and bobbin case. Tilt machine head back, and set zig zag regulator knob on setting 0. Thread machine, and turning balance wheel slowly, observe the needle travel, and its relation to the shuttle point when needle starts its upward travel.

Timing is incorrect if shuttle point doesn't pick up the upper thread.

To adjust, loosen set screw on needle bar, through driver hole (figure 88), and move needle bar until needle is in proper position.

Figure 88b shows proper position of needle in relation to shuttle point, at lowest point of needle bar travel.

Tighten set screw, replace shuttle components, and test sew.

Figure 88a, shows position of needle bar at lowest position. Measurement between arrows should be about $25/64$ ".

The proper distance between eye of needle and point of hook, at position shown in figure 88b, is $3/32$ ".

Before timing a sewing machine, always start with a new needle, and be sure needle is properly inserted.

To adjust clearance between needle and point of hook, loosen shuttle race block screw, illustrated in figure 88c.

Proper clearance is $.004$ ". This is quite close, about the thickness of a piece of paper, doubled.

Move entire race assembly and observe. Remove needle plate.

Check needle position. Race assembly must not turn while this adjustment is being made. The needle must pass through center of slot.

Tighten set screw on race block, replace needle plate and test sew.

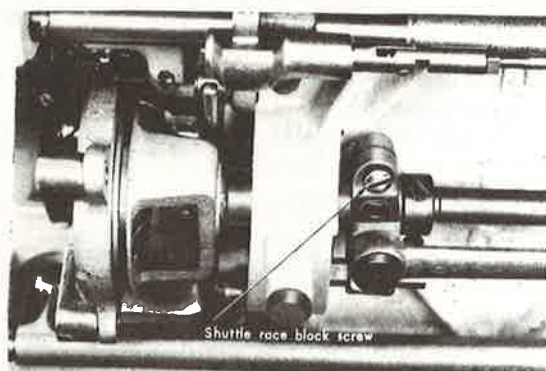

Relation of shuttle race upper spring and needle position

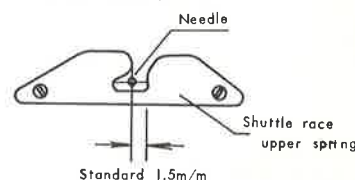

Figure 88c

Adjusting the oscillating shaft

When there is end-play in the oscillating shaft, loosen set screws on the shaft collar and adjust. See figure 89.

Move collar slightly to the left, and the shaft to the right.
Tighten set screws snugly.

Turn balance wheel slowly. If machine binds, collar is too tight.
Loosen set screws and back collar off slightly. Tighten set screws.

Figure 89

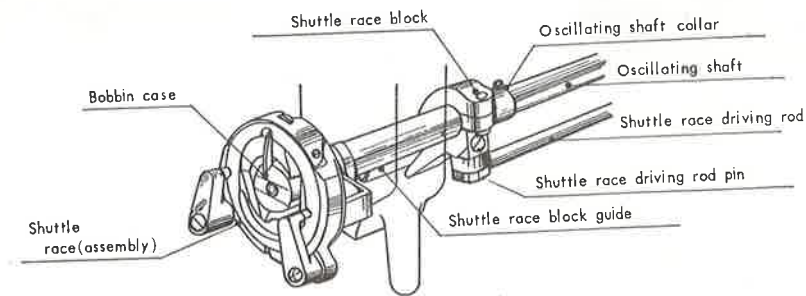

Adjusting the feed dog

The proper height of the feed dog is $1/32$ " above needle plate, at its highest point.

If adjustment is required, loosen feed lifting rock shaft crank clamping screw (figure 89a), and adjust as needed. (Figure 89a on page 89).

If feed dog is too low, raise it to proper height. If it's too high, lower to proper height, at high point of feed dog rise.

Tighten set screw and test.

Although this adjustment should solve the feeding problem, the presser bar unit might also need adjusting, and don't overlook the drop feed. It may be in "DOWN" position.

If problem is in presser bar assembly, open face plate door, and raise the presser bar lifter (figure 89b), on page 89.

There should be about $1/4$ " clearance between the needle plate and lower part of presser foot, when lifter is in "UP" position.

Loosen set screw on presser bar guide bracket.
Adjust to proper setting and tighten set screw.

When making this adjustment, hold presser bar firmly in place. If the presser bar slips, needle will strike presser foot, especially on wide zig zag.

If pressure seems to be insufficient to feed material, screw patchomatic down as far as it will go. If the foot still lacks enough pressure, remove the darner assembly, and presser spring.

Stretch the spring, replace darner assembly and spring. Test sew.

Figure 89a

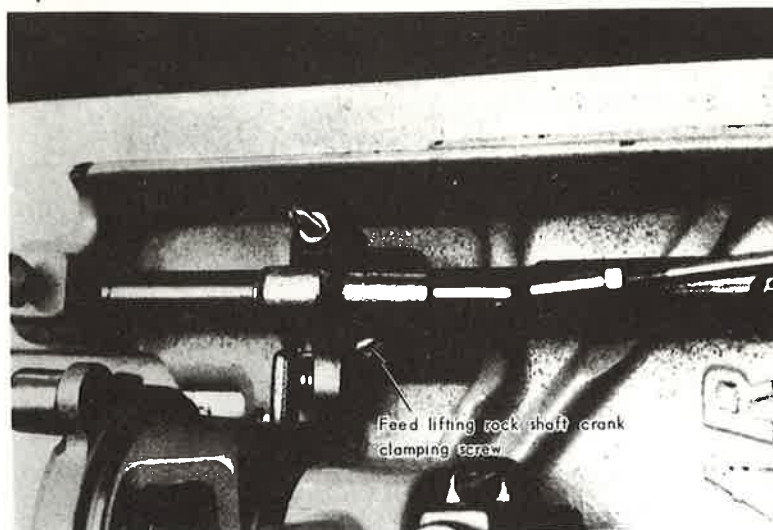
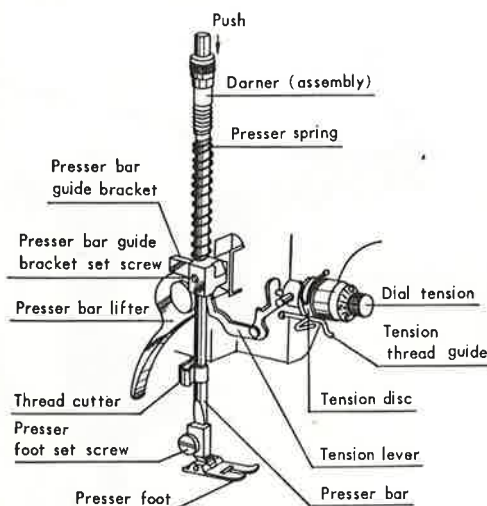

Figure 89b



Timing the feed system

When the feed system is properly timed, the feed dog starts its motion, when the needle is at its highest point.

To adjust, place stitch length control lever on longest stitch.

Loosen feed cam set screw.

Move the cam until angle changes. Tighten set screw and test.

If further adjustment is needed, repeat the procedure.

To advance the feeding, turn cam clockwise.

To retard the feeding, turn cam counterclockwise.

Most machines have a timing mark on the feed cam. Set it on mark cut on the arm shaft and feed timing should be accurate.

Figure 90

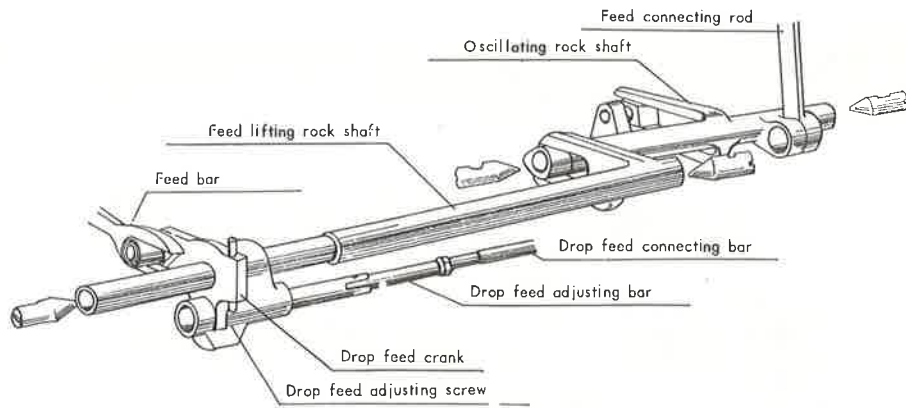

Figure 90: Feed lifting assembly.

Figure 90a

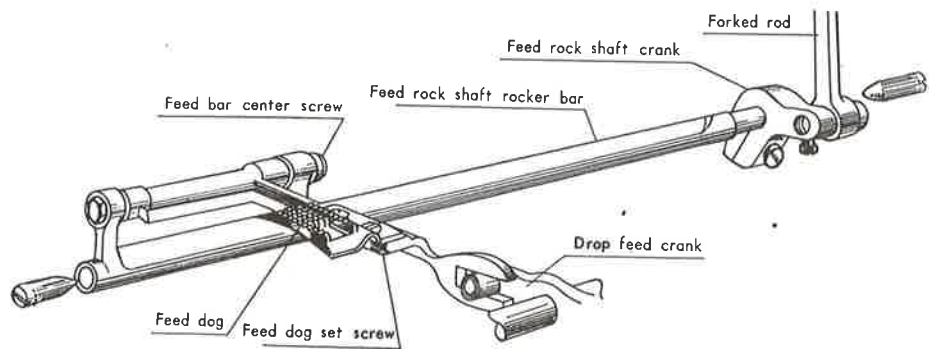
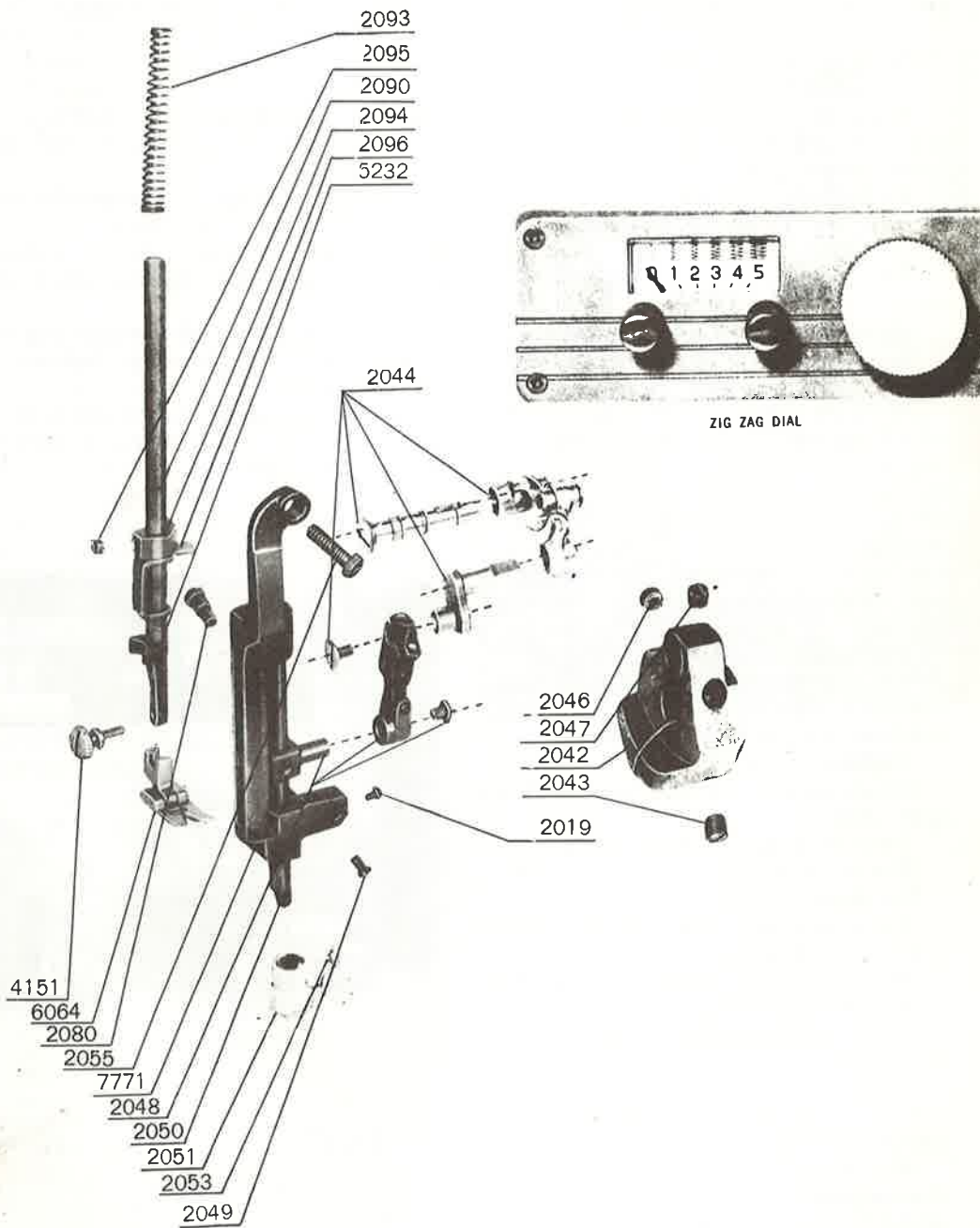

Figure 90a: Feed rock shaft and feed dog.

Figure 91 illustrates the components of a swing needle frame, and a zig zag control dial.

When the dial is set on 0, the machine sews a straight stitch seam. As the dial is moved, a bar attached to the dial and the needle frame starts to move, causing the needle to swing back and forth, creating the zig zag stitch. When the dial reaches 5, the zig zag width is about 1/4" wide.

Figure 91



When the zig zag dial is activated, the needle frame(771) pivots from the main screw(055) in head cast and swings as zig zag dial is moved. The amount of swing is determined by zig zag dial. The connecting link from zig zag control to swing needle frame is attached to lower end of frame with screw(2080).

The needle bar is connected to the main cam by a connecting rod which in turn attaches to the stud which screws into the main frame.

The basic difference between regular straight stitch and zig zag machine needle bar connection, is the length of the stud. The zig zag stud must be longer to compensate for crosswise movement of the needle bar.

Adjusting the zig zag control.

Biggest complaint of user with a zig zag machine is the failure of the machine to sew straight when set on 0, or that the control lever will not move back to 0.

To adjust, remove top and face plate cover. Remove automatic darning screw in face plate and two screws across the top of machine.

On some machines the spool pin acts as a top fastener, if so, remove it.

This adjustment covers the 900, but all single zig zag machines adjust very much alike.

Move stop screws to maximum position at each end of the zig zag dial.

Loosen screw(I) and move lever, or dial to 0. Figure 92 below. Move link(H) against the frame(X) and tighten screw(I).

If this adjustment doesn't allow full zig zag swing to 5, loosen lock nut(J) and turn allen screw(K), inward until lever or dial reaches maximum throw. Tighten lock nut(J). Test sew and adjust as needed.

A slight tension is needed to prevent lever, or dial from creeping during operation.

If creeping occurs, loosen nut(F) and turn screw downward until corrected.

Tighten nut and test sew.

To prevent zig zag on 0 setting, loosen screw(D) and move block(E) until axis matches groove(A).

Tighten screw(D).

Seam should not zig zag on straight stitch.

To test, activate drop feed.

Put a card under presser foot.

Set dial, or lever, on 0.

Turn balance wheel until needle enters card a few times.

Needle should enter the hole in same place each time. If it doesn't, recheck adjustment and adjust until corrected.

After adjustment is completed, clean working parts with a solvent saturated cloth.

Allow parts time to dry, then oil thoroughly and replace top and face plate cover. Replace darning.

Figure 92

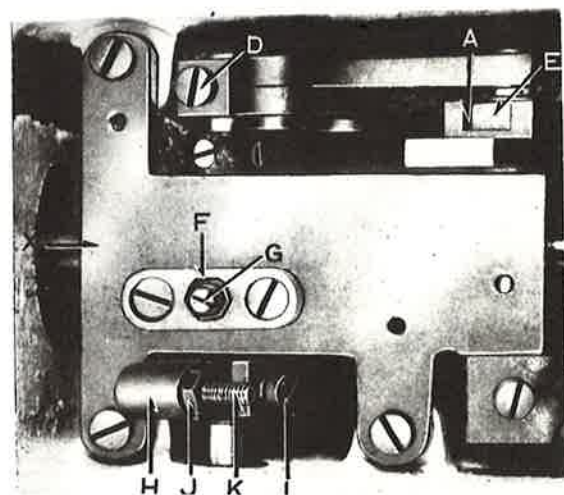

Needle position adjustment.

On an 0 setting, the needle should enter the needle hole on the left side of the needle hole.

If it doesn't, remove the face plate and adjust.

Zig zag control is on 0, loosen set screw(A) and turn eccentric screw(B) until the needle descends in extreme left position.

For perfect adjustment, put straight stitch needle plate on machine.

Remove it when you resume zig zag sewing.

Tighten set screw(A), replace face plate, and zig zag needle plate.

Test sew.

Figure 93

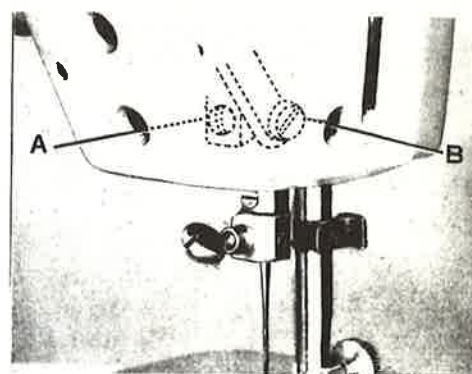

Timing needle bar motion.

To time downward motion of needle bar, set zig zag lever on 5.

Place card under presser foot, lower drop feed and turn balance wheel several times.

Needle should enter the card at precisely the same place, without moving the card.

Loosen screws(A) and rotate gear (B) toward you, slightly.

Tighten set screws(2) and test sew. Adjust as needed.

When adjustment is correct, needle stops swinging motion 1/4" above the needle hole.

Figure 90 illustrates proper path for descending needle.

Figure 93a

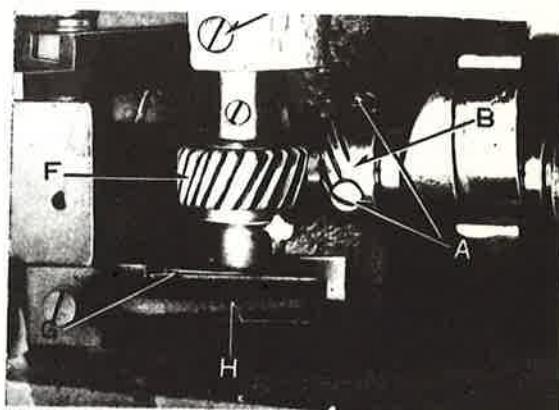
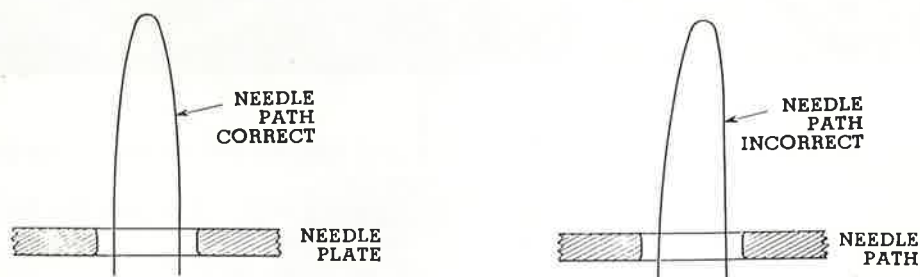

Figure 93b



Timing needle bar with shuttle.

Correct timing of needle bar in relation to hook is present when point of shuttle passes over eye of needle, as needle starts to rise.

The correct distance is $3/32''$ between upper needle hole and hook point. Figure 94 shows needle at lowest point.

Figure 94

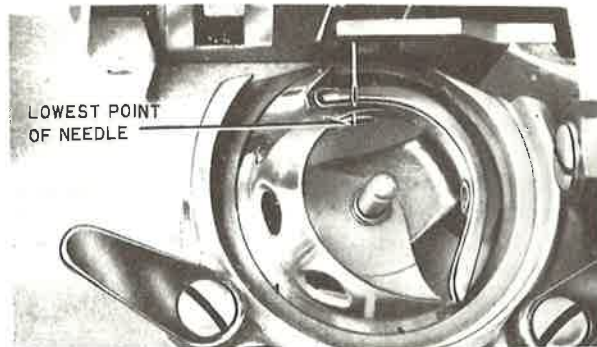

As sewing cycle continues, hook approaches as the needle starts to rise. When point of hook reaches needle at proper time, the distance is $3/32''$ as illustrated in figure 94a.

If this measurement varies, adjustment must be made at needle bar.

Figure 94a

Figure 94b

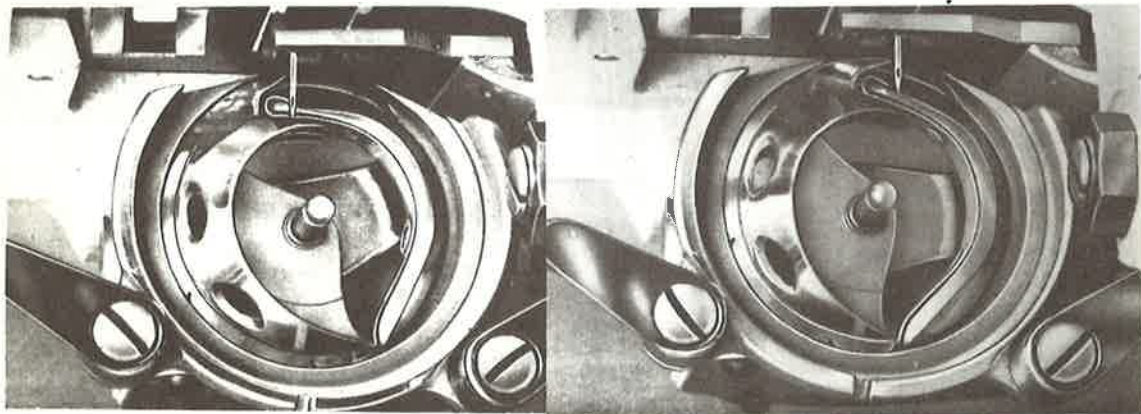

To adjust, remove face plate assembly and loosen set screw in needle bar block(2048), figure 91.

Set zig zag lever on 5, remove needle plate and lower needle to proper height.

When needle is properly set, tighten set screw.

Replace components and test sew.

Caution: Always start adjustment with a new needle. Old needle could be bent or dull and disrupt timing procedure.

Feed System.

The feed bar and raising system is almost identical to the standard class 15 machine.

Most single needle position zig zag machines feature a drop feed. Refer to page 48, chapter 2.

To adjust the feed dog height, tilt head back and turn balance wheel until feed dog is at highest point above needle plate.

Drop feed must be in "UP" position.

Loosen screw(B) and adjust until $1/32$ " of teeth show above upper level of needle plate.

Turn clamp(C) until correct. Tighten set screw(B) and test.

Figure 95

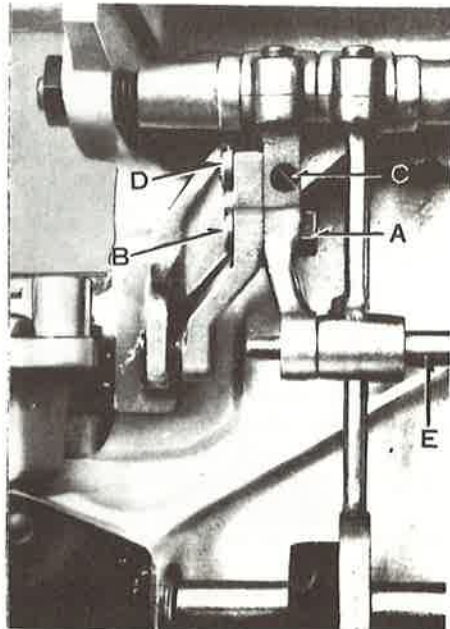

Replacing feed dog.

To replace feed dog, loosen set screw and remove needle plate. Loosen screws(D) and remove. Replace components and test sew.

Figure 95a

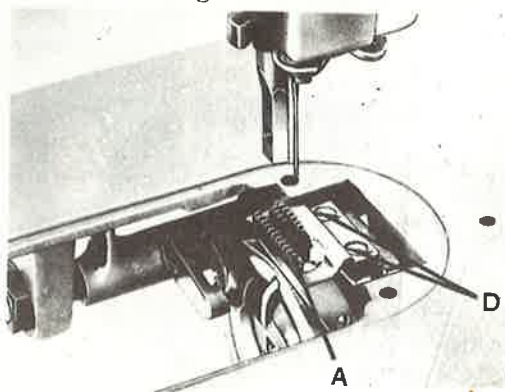

Presser bar assembly.

The presser bar assembly is similar to Class 15 machine, covered in Chapter 2.

Pressure on the presser foot is regulated by the spring and block assembly with the automatic darning acting as regulating agent.

Figure 96 illustrates the darning in up position for darning or mending.

As the button is lowered in degrees, it forces the spring against the block and exerts more pressure against the presser foot.

Proper adjustment is down completely for heavy sewing. Up a couple of notches for regular sewing and up about four notches for lightweight or synthetic fabric.

Proper height between bottom of the presser foot and needle plate is $1/4''$.

To adjust, remove face plate, or swing open if face plate is hinged, and observe set screw on adjusting block.

Loosen the screw and move presser bar until correct adjustment is attained.

Tighten screw, replace face plate assembly and test sew.

Presser foot should press firmly against material.

To test, place a business card under presser foot and lower in place. If the foot holds business card firmly when you pull it, adjustment is correct.

When adjusting position of presser bar, always hold it firmly in place. Before tightening the set screw, lower presser foot and check relation of its position to needle plate hole.

If they are not aligned, loosen set screw and align. Hold bar firmly when tightening.

Most zig zag machines have a high shank presser bar. Never attempt an adjustment with a low shank presser foot, or vice versa.

Drop feed.

The drop feed may be located in various places, depending on manufacturer, but most will be located on bed of machine near the right side.

See figure 97, opposite.

Some of the later models feature the drop feed on the arm, near the length of stitch indicator.

Older models may have a button or release screw under the bed of machine, near the feed raising block.

Adjustment pertaining to Class 15 machine can be followed for adjusting the 900 type zig zag.

If user complains machine doesn't feed, check drop feed button first.

Figure 96

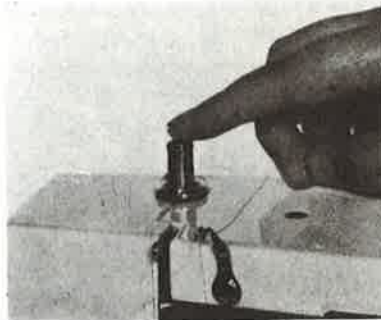
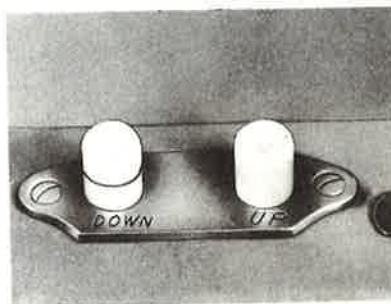

Figure 97



Bobbin winder.

The bobbin winder is the same as the conventional class 15, however, a few machines now feature a built-in winder, with the spindle showing above upper arm of machine.

To adjust winder on this machine, the top cover must be removed.

Activating lever should force rubber ring against balance wheel. If not, loosen set screw and manually move the winder until rubber touches wheel.

Tighten adjusting screw and test.

Loosen clutch by turning knurled knob counterclockwise.

See figure 98, below.

Figure 98



Adjusting motor drive.

When machine shows lack of power, and it's been determined the motor and control are operating properly, loosen screw(A), figure 99 and move motor mount downward until belt tension is sufficient to run machine.

Tighten screw and test.

If belt is too tight and machine binds instead of operating smoothly, reverse the procedure.

For complete information on electrical equipment, see Chapter 8.

Figure 99

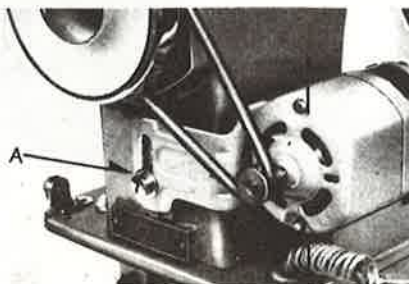

Chapter Six

The Automatic zig zag.

The automatic made its debut in the early 1950's. Elna, which is made in Switzerland, came on the scene with a free arm and single drop-in cam for each decorative stitch.

The Necchi, Pfaff, Viking and others followed in quick succession. Singer made a zig zag, but it proved to be non-competitive so they dropped it.

This chapter will cover three popular European machines and two of Japanese origin.

Automatics perform various sewing tasks without attachments. Button-hole, blindstitch, overcast and sewing on buttons can be done with the flick of a switch or control. Basically, the difference between automatics on the market is the way they sew decorative stitches.

Some make utilize the stack cam system, with five or six different designs on a single cam. To change designs, the operator moves a lever or dial and indicator points out design machine will make.

Another type features a cam at a time. The user must change cams to change designs.

The third and most complicated from a service standpoint is the machine with built-in cams. The cams are generally constructed of steel and remain permanently affixed to the machine.

The Pfaff.

The Pfaff is manufactured in Germany by the G.M. Pfaff AG Company. It has been a top quality machine since the late 1880's.

Figure 101

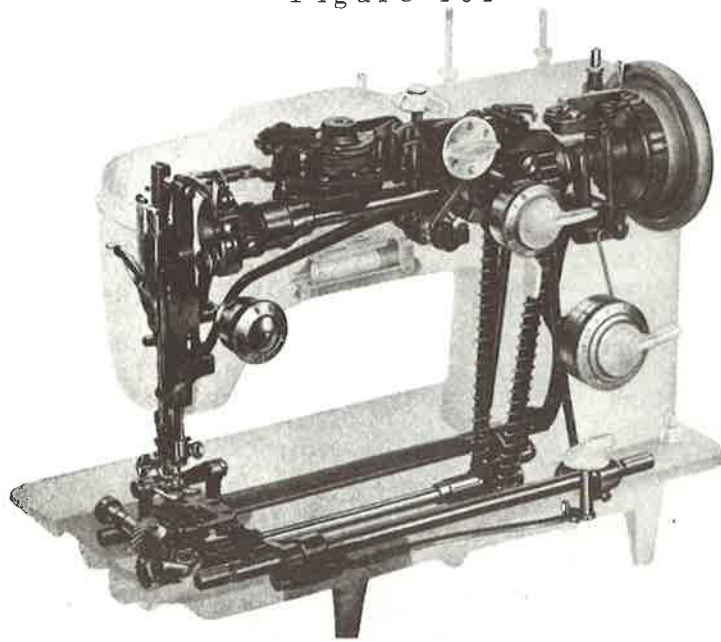

Skeleton of a Pfaff Automatic sewing machine.

Figure 102

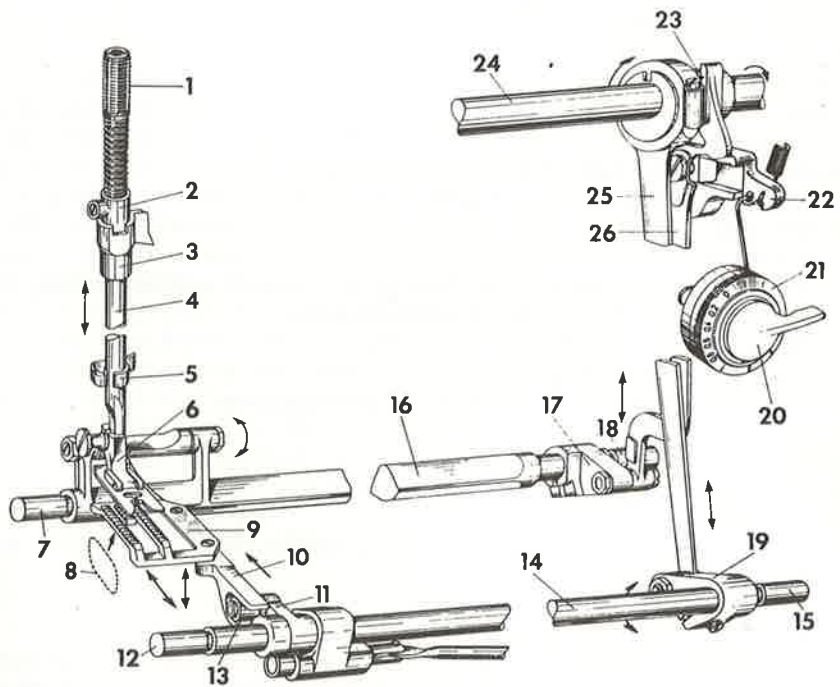
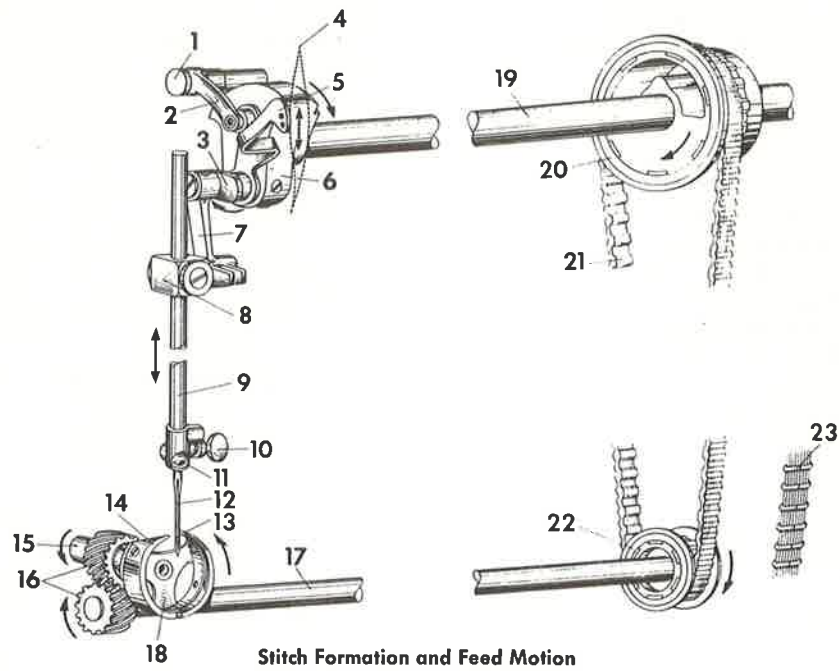

Nomenclature for Figure 102-Pfaff 230-360

1. Hinged stud from main cam.
2. Take-up arm link.
3. Connecting crank.
4. Take-up arm travel. (illustrated to show path).
5. Take-up arm.
6. Main cam. (Activates needle bar and take-up arm).
7. Connecting link to needle bar.
8. Needle bar stud.
9. Needle bar.
10. Needle clamp screw.
11. Needle clamp.
12. Needle.
13. Hook.
14. Hook thread guard.
15. Hook spindle.
16. Helical drive shaft gears. (Pfaff has a transverse hook).
17. Lower drive shaft.
18. Main hook body.
19. Main shaft.
20. Upper belt sprocket.
21. Drive belt.
22. Lower belt sprocket.

Nomenclature for feed mechanism(lower figure 102)

1. Regulator screw for presser bar.
2. Presser bar guide and adjustment block.
3. Presser bar lifter bracket.
4. Presser bar.
5. Thread cutter.
6. Presser foot.
7. Retainer stud, lower feed mechanism.
8. Indicates feed dog travel pattern.
9. Feed dog.
10. Feed fork.
11. Feed lifting assembly, including drop feed and adjusting screw.
12. Retainer stud, lower feed mechanism.
13. Roller.
14. Main feed lifting shaft.
15. 18. Retainer studs, lower feed mechanism.
16. Feed rock shaft.
17. Rock shaft crank assembly.
18. See above.
19. Feed lifting crank.
20. Stitch regulator(260-360) 130 assembly shown in future text.
21. Stitch length dial.
22. Feed regulator assembly.
23. Feed eccentric(attached to main shaft(24).
25. Feed lifting connection.(from main shaft to lower assembly).
26. Feed fork connection. (from stitch regulator to feed lifting shaft.

Upper tension.

- A. Tension holder.
- B. Check spring.
- C. Tension discs(2).
- D. Middle tension disc.
- E. Tension spring.
- F. Tension stud.
- G. Tension release pin.
- M. Numbered tension dial.

Sub-assembly for check spring.

- a. Set screw for removing assembly from machine.
- b. Check spring loop. (If broken or missing, replace).
- c. Regulator. Adjust for changing throw of check spring.

Figure 103

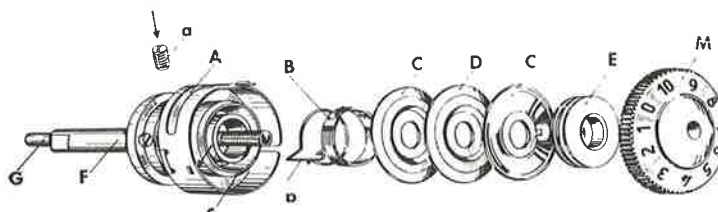

Tension adjustment on the Pfaff is a relatively easy chore. The adjustment dial(M) is calibrated from 0 to 10, giving a wide variety of settings for the user.

It's wise to jot down the number where machine sews a proper stitch and keep it near the machine. If tension is changed for a special sewing chore, good tension can be restored by glancing at the number.

As a general rule, a tight stitch is used for straight sewing and a looser stitch for zig zag or fancy sewing.

The Pfaff, also true of most automatics, has a third tension disc for the double needle application. A separate control is not required as one dial, controls both threads.

The tension is preset at 3 or 4 at the factory.

If the setting has been altered, proceed as follows.

1. Loosen face plate and upper cap assembly and remove. Loosen the set screw and remove tension assembly. Turn dial(M) until red indicator points to 0 on the dial.

Pull a length of thread through discs(C-D) and turn stud(F) into dial (M) until a light tension is present. Hold dial firmly, replace stud and tighten set screw.

Turn dial to 3 or 4. When properly set, the red indicator should point upward.

2. To replace a broken or bent check spring, follow same procedure for tension adjustment and remove assembly.

Screw tension stud out of dial until other components can be removed. Replace broken spring and replace components in reverse order.

Extreme caution must be exercised when slipping spring loop over the red indicator.

Tension adjustment illustrated.

Probable cause:

1. Upper tension too tight.
2. Lower tension too loose.
3. Improper check spring setting.

Correction:

1. Turn dial to 3 or 4 setting, or reset tension per text page 99.
2. Tighten knurled screw on bobbin case, notch at a time until corrected.
3. Proper adjustment of check spring is present when spring releases thread as needle enters the cloth.
For a weak spring (releases thread too soon), loosen small screw in slot by red indicator and turn regulator down.
If spring is too tight, reverse the procedure.
When properly adjusted, spring should fall sharply to spring rest.
If check spring is broken or bent, replace it.

Figure 104

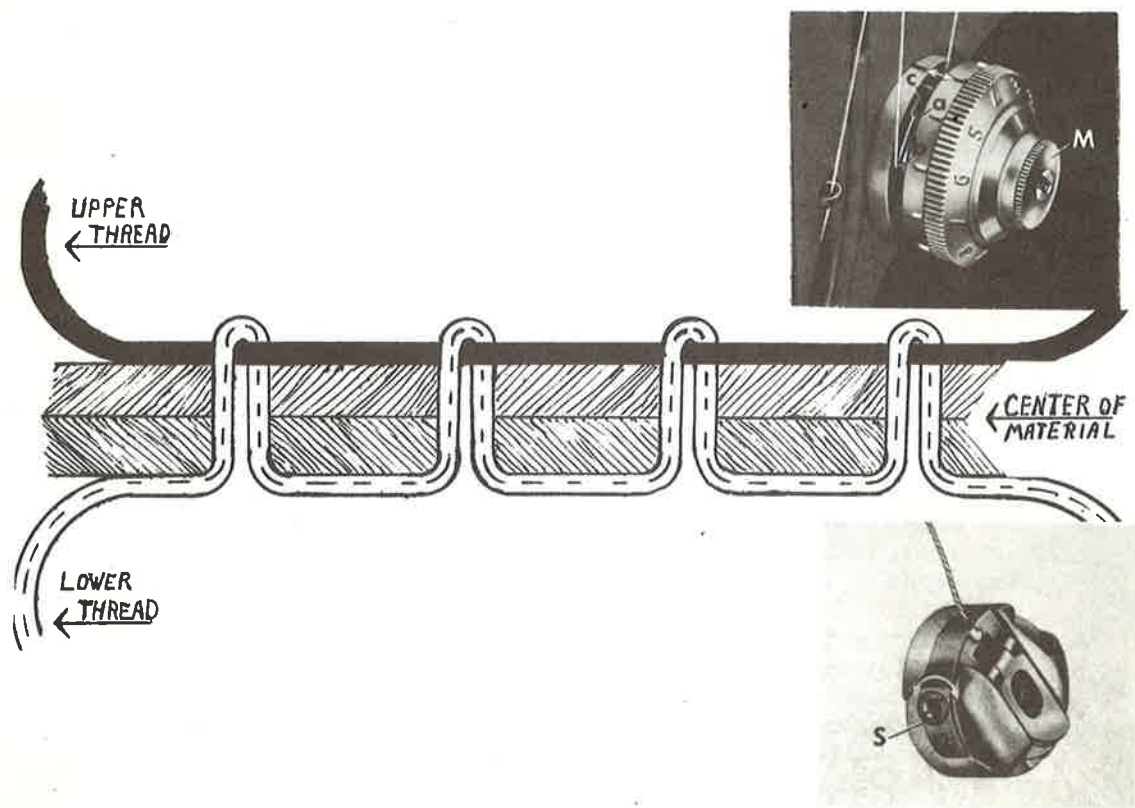

Lower tension.

Adjusting proper tension on the Pfaff 260-360 sewing machine is a departure from methods used on previous machines.

1. The above models feature a calibrated knurled screw instead of split screw used on other models. To adjust, turn clockwise for more lower tension, opposite for less. Tension should be tight enough to allow bobbin case to slide down the thread when held in position as in figure 105.

Adjustment screw(S) changes lower tension.

When bobbin case falls rapid, turn screw a notch, clockwise until corrected.

If jerking motion fails to move case, reverse adjustment until corrected.

Test sew.

Figure 105

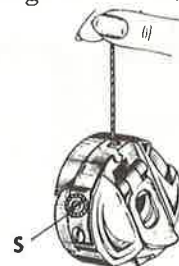

Figure 106 illustrates stitch created when lower thread pulls upper through material.

If upper thread is too loose, tighten dial M as needed.

If lower tension is too tight, follow text above until corrected.

Test sew.

Figure 106

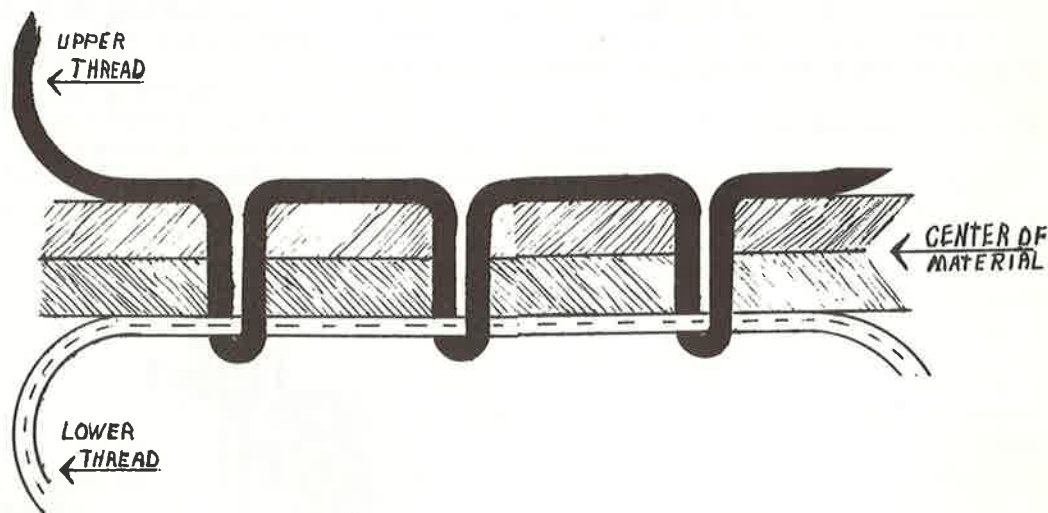
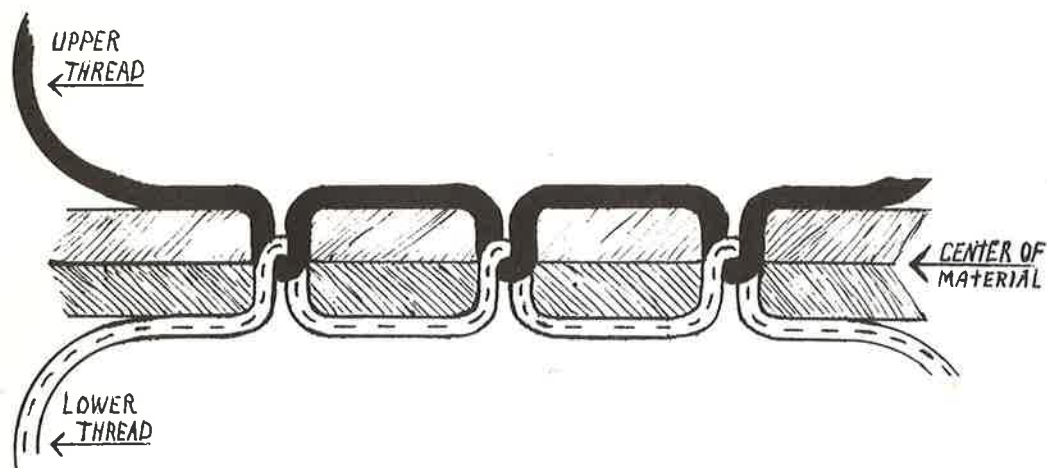

Figure 107 illustrates how the threads should appear after both tensions have been properly adjusted.

Dial M should be between 3 and 4 setting.

Bobbin case should drop slowly when thread test from figure 105 is made.

Figure 107



Tension adjustment on zig zag stitch should show a lock at the zig and zag of the seam.

Most zig zag machines require a slightly lighter tension for zig zag and decorative stitching. Straight stitch tension should remain normal.

Use a tighter tension for making buttonholes.

If several adjustments fail to produce a lock at the zig and zag of a seam, sew with a loose tension on top and one notch tighter on the bottom. The seams do vary slightly, even with a factory setting.

Double needle.

Pfaff machines have two tension disc tension assembly plus a third for double needle sewing.

The take-up arm is drilled for both threads.

A different needle clamp must be installed to accommodate two needles.

Remove the single clamp and attach double clamp to needle bar. See figure 108.

Tighten screw(d).

Presser foot and needle plate must be exchanged for one used with double needle.

Caution: Check zig zag dial. Can't use past a 2 setting.

If user complains that machine breaks double needles constantly, check this setting.

Figure 108

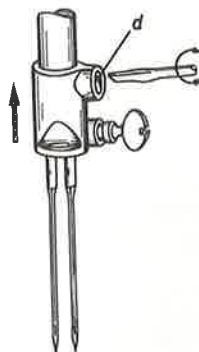

Hook assembly

Figure 109

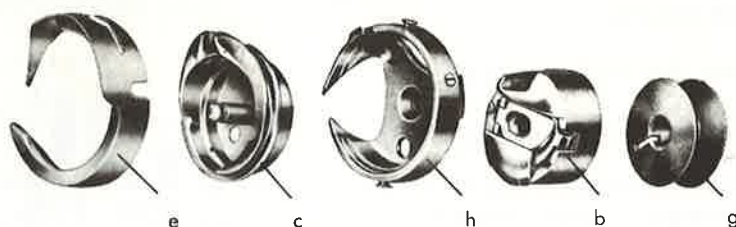

Figure 110

- a = Position slot
- b = Bobbin case base
- c = Bobbin
- d = Bobbin case latch
- e = Bobbin case cap
- f = Sewing hook
- g = Hook point
- h = Hook thread guard



The hook and bobbin case assembly are transverse. If the assembly is broken (point of hook, etc), or machine jumps time, adjust as follows.

1. Remove position finger, then remove hook, with caution.
2. Loosen set screw (a), and remove parts b, c, d & g (figure 111).
3. Check position of hook point.

Clearance between point of hook and needle should be .004".

Replace parts in reverse order from removal.

Tighten screw (a) and replace position finger.

Position finger should be exactly $1/32$ " from end of position slot.

Figure 111

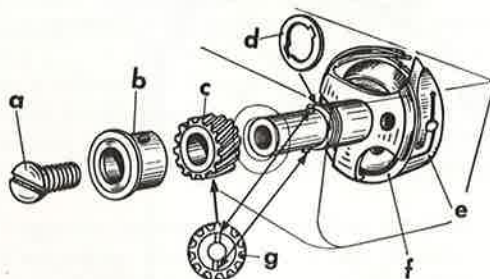
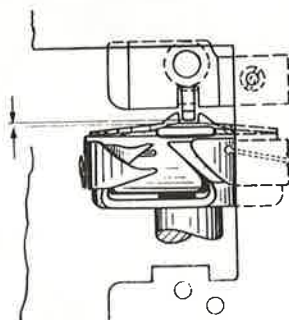

Figure 112



Hook assembly

Figure 109

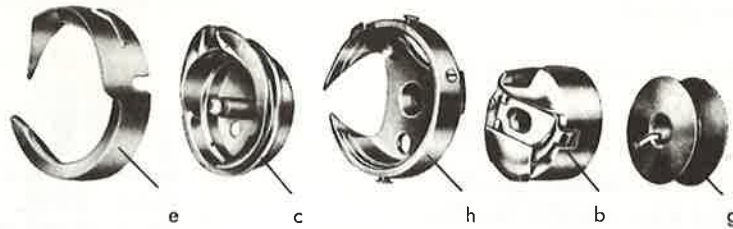
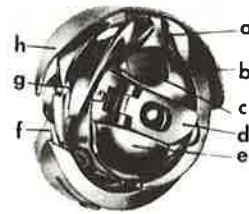

Figure 110

- a = Position slot
- b = Bobbin case base
- c = Bobbin
- d = Bobbin case latch
- e = Bobbin case cap
- f = Sewing hook
- g = Hook point
- h = Hook thread guard



The hook and bobbin case assembly are transverse. If the assembly is broken (point of hook, etc), or machine jumps time, adjust as follows.

1. Remove position finger, then remove hook, with caution.
2. Loosen set screw (a), and remove parts b, c, d & g (figure 111).
3. Check position of hook point.

Clearance between point of hook and needle should be .004".

Replace parts in reverse order from removal.

Tighten screw (a) and replace position finger.

Position finger should be exactly 1/32" from end of position slot.

Figure 111

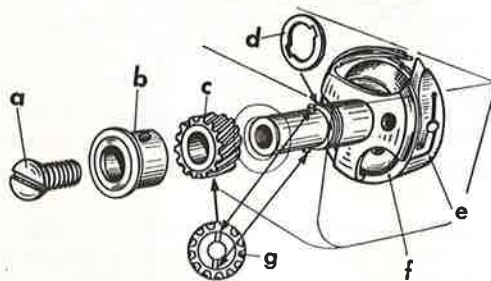
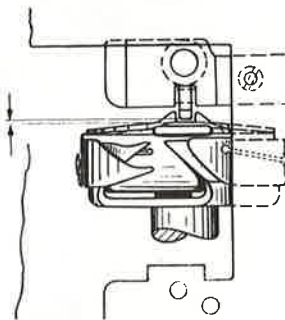

Figure 112



Timing the needle bar.

If the machine continues to skip stitches after the hook has been timed, the needle bar must be timed.

1. Set machine for widest zig zag stitch.
Put position lever in center position.
Remove face and needle plate.
Turn balance wheel until needle is on down stroke.
2. Loosen screw(A) through opening in needle bar frame.
Hold needle bar firmly so bar doesn't turn.
Correct height: Point of hook should be .02" above top of the needle eye.
Position needle bar and tighten set screw(A).
Replace face cover and test sew.

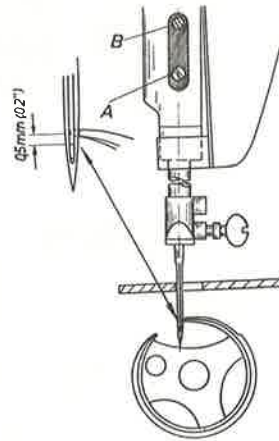

3. For centering the needle throw in needle plate slot, set zig zag dial on 4. Place position lever in center notch.
Turn balance wheel and observe needle descent. Needle should be the same distance from plate on right and left descent.
To adjust, loosen set screw(a), figure 114, and turn eccentric correct direction to adjust.
4. Centering throw in relation to center line, requires zig zag dial on 0 and position lever(B) in center position.
Place a business card under presser foot. Lower foot and turn the balance wheel until needle stitches it slightly.
Turn zig zag dial to 4 and watch needle as you turn balance wheel. The two outer punctures should be equidistant from center puncture.

Figure 114

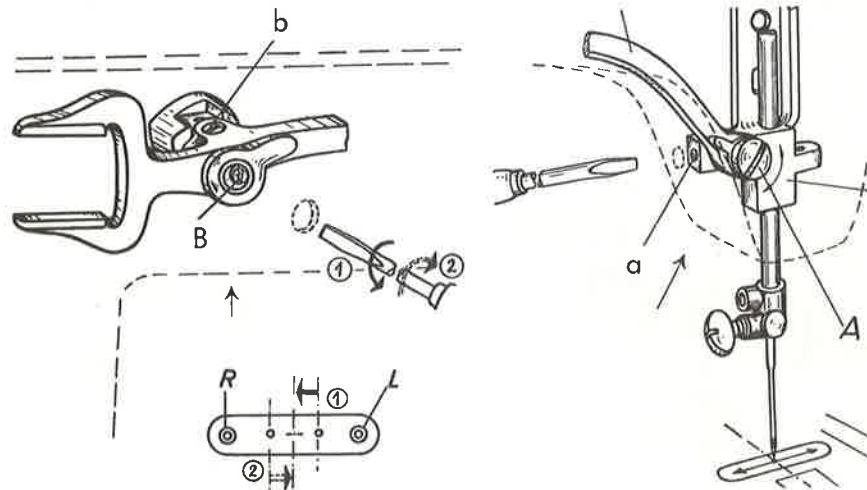

When finalizing the adjustment pertaining to needle bar adjustment, remember the needle must not make a sidewise motion while in the material.

With zig zag dial set on 4, the needle should stop swinging motion exactly $5/32$ " above needle plate.

Feed system.

Feed dog adjustment should be made if material isn't feeding properly.

Check drop feed lever. If it's set in "UP" position, tilt machine head back. Raise presser foot and turn balance wheel until feed dog rises to highest position.

Loosen set screw on front feed crank and move feed dog upward until the teeth are $1/32$ " above upper level of needle plate.

Tighten set screw, replace head in sewing position and test sew.

Feed dog adjustment in needle plate slot.

Correct position places feed dog in center of needle plate slots.

If situation resembles position 1, remove needle plate and loosen two feed dog screws.

Position properly, hold in place, and tighten screws.

If like position 3, replace needle plate, tilt head back and loosen both rock shaft studs.

Tap shaft with small hammer until feed dog is properly set.

Be sure flat spot on shaft face the screws.

Tighten and test.

Don't overadjust, rock shaft must have some end play.

If machine binds after you've made this adjustment, loosen screws and back off slightly.

If position 3 is extreme, adjustment must be made on the feed bar.

Loosen lock nuts(1, figure 116).

Turn screws(2) direction needed.

Tighten lock nuts and test sew.

Always allow a little end play so machine won't bind.

Lengthwise adjustment as in position 2, is made by setting length of stitch lever on longest setting.

Tilt head back. Loosen crank.

Turn crank until center feed row rises in needle plate without striking it.

Tighten screw. Turn the wheel.

Feed dog shouldn't strike plate.

If it does, adjust until corrected.

Figure 115

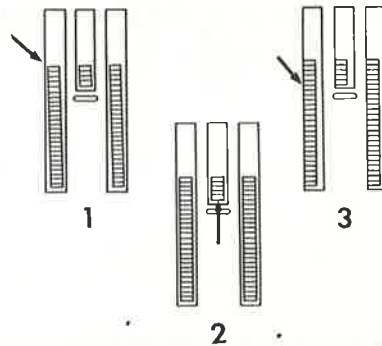

Figure 116

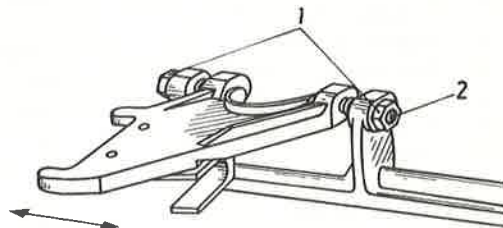
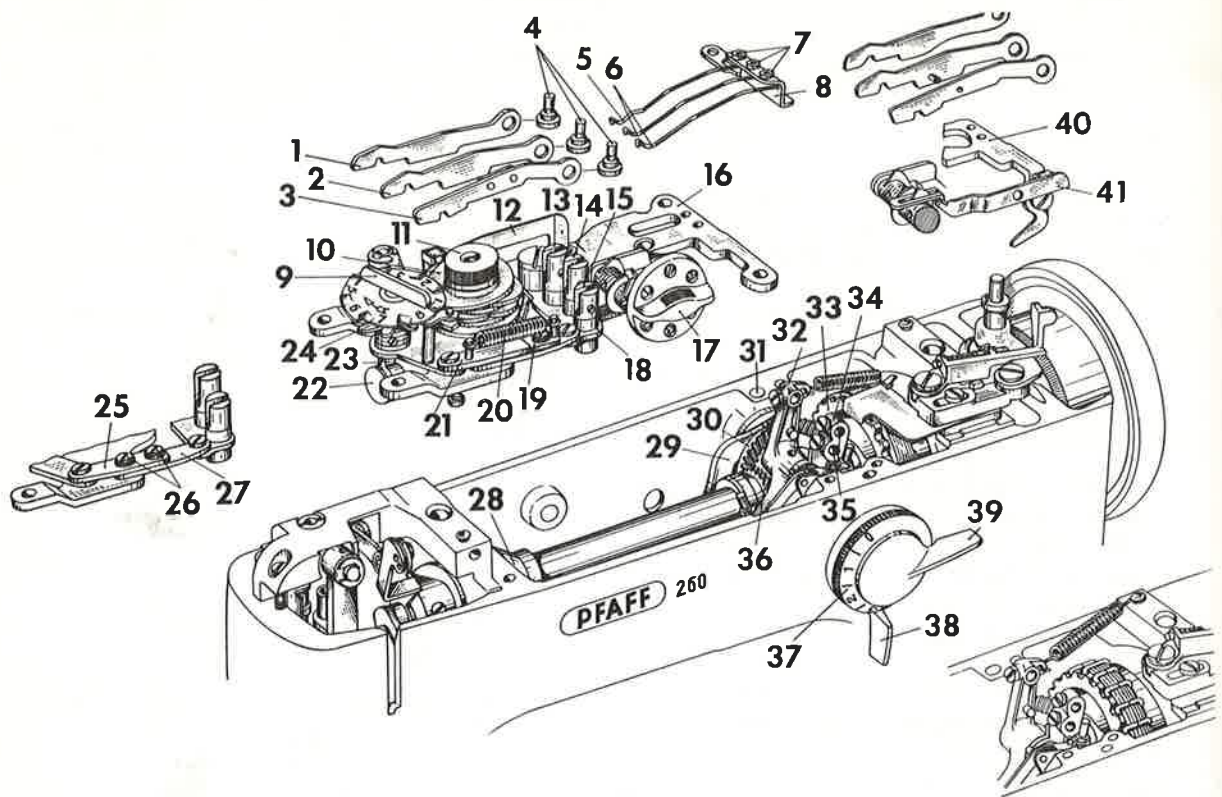

Figure 117



Essential Parts of the Pfaff (-261) Automatic

- | | |
|---|--|
| 1 = Needle position engaging lever | 21 = Connection, rear section
(incorporated until Apr. 30, 1960) |
| 2 = Needle vibration engaging lever, full width | 22 = Driving roller |
| 3 = Needle vibration engaging lever, half the width | 23 = Driving lever |
| 4 = { Eccentric stud, rear
Eccentric stud, center
Eccentric stud, front | 24 = Contact finger assembly |
| 5 = Pressure spring, rear | 25 = Connection, rear section
(incorporated as from May 1, 1960) |
| 6 = { Pressure spring, center
Pressure spring, front | 26 = Screw |
| 7 = Regulating screw | 27 = Connection, front section
(incorporated as from May 1, 1960) |
| 8 = Pressure spring assembly bracket | 28 = Driving eccentric for automatic mechanism |
| 9 = Cam selector dial (D) | 29 = Needle bar frame pitman |
| 10 = Cam assembly | 30 = Needle vibrating eccentric bevel gear |
| 11 = Thumb nut | 31 = Transverse shaft set screw |
| 12 = Oil pad holder | 32 = Zigzag regulator arm |
| 13 = Clutch stud, rear | 33 = Driving belt sprocket, upper |
| 14 = Clutch stud, center | 34 = Cam finger (upper end) |
| 15 = Clutch stud, front | 35 = Eccentric stud boreholes |
| 16 = Base (incorporated until Apr. 30, 1960) | 36 = Arm shaft bevel gear |
| 17 = Engaging lever dial (C) | 37 = Stitch width dial (A) |
| 18 = Engaging lever driver | 38 = Needle position lever (B) |
| 19 = Connection, front section
(incorporated until Apr. 30, 1960) | 39 = Zigzag finger-tip control (F) |
| | 40 = Base (incorporated as from May 1, 1960) |

Feed eccentric.

To time the feed eccentric, remove the top plate and refer to page 97.

Both the eccentric (illustrated under number 23) and the main shaft (24), have a timing mark.

When the marks coincide, the machine's feeding mechanism is in time.

If eccentric has moved on the shaft, loosen screw and return to within $5/64$ " of rear main bearing and tighten set screw.

When this occurs, the upper drive sprocket is generally out of place also. Loosen set screws and move toward eccentric.

Be sure position pin fits hole on eccentric. Tighten all screws and test.

Drop feed.

Drop feed lever is located at right end of machine bed.

When activated, the feed dog drops below needle plate level and material will not move.

Only adjustment required is when feed dog is set too high and continues feeding material after drop feed has been lowered.

Tilt machine head back and loosen set screw on feed lifting crank.

Raise feed manually to high point of $1/32$ " above needle plate. Tighten set screw and test.

Length of stitch regulator.

The stitch length regulator is calibrated for different lengths of stitch for forward and two settings in reverse.

To sew in reverse, the operator pushes lever down. When finished, she releases lever and lever returns to original forward setting.

The regulator also contains a setting for fine short stitching used in decorative stitching.

To adjust, remove top cover and disconnect spring.

Tilt machine head back, loosen set screw and set control on 0.

Turn balance wheel by hand. Feed dog should rise and fall in place.

If feed dog moves, even slightly, back, adjust screw until corrected.

Make adjustments in small increments.

Tighten screw, connect the spring. Replace cover.

Don't over-adjust or machine will sew in reverse on a forward setting.

Presser bar.

The ideal setting for space between presser bar in up position and needle bar should be $1/4$ ".

If setting is lower, it's difficult to insert material. If higher, full pressure of presser foot is not applied to material.

To adjust, remove face plate. Loosen set screw on guide collar.

With presser bar in "UP" position, set for proper clearance and tighten set screw.

Replace face plate and test sew.

Caution: Don't allow presser bar position to change during adjustment. Before tightening set screw, lower presser bar and check relation of foot to needle hole and feed dog.

Place zig zag control on 4 and turn balance wheel. If needle clears, tighten set screw.

For regular sewing, regulating cap should be flush with top of casting.

For lighter material, turn out a couple of turns. For heavier fabric cap must be turned down a couple of turns.

Bobbin winder.

The bobbin winder is built-in with only the winder spindle protruding.

If the bobbin winds unevenly, adjust as follows:

If thread piles up on top end, move stem to right. If thread piles up on the lower end, reverse procedure.

When rubber ring wears and winder doesn't activate, loosen set screw.

Move winder toward balance wheel until rubber ring touches. Tighten the screw, test. If ring rides too hard on balance wheel, reverse procedure.

If rubber ring shows sign of wear, replace it.

Balance wheel.

The Pfaff balance wheel has a groove on outer rim of wheel.

On machines with exterior motor, belt fits in groove and drives machine.

On machines with built-in motor, belt fits over sprocket in head.

Figure 118 illustrates breakdown of balance wheel and clutch assembly.

Figure 118

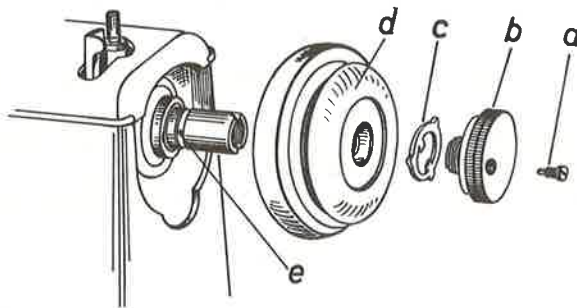
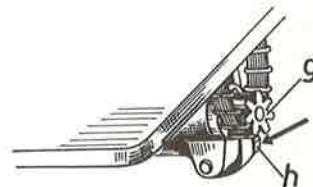
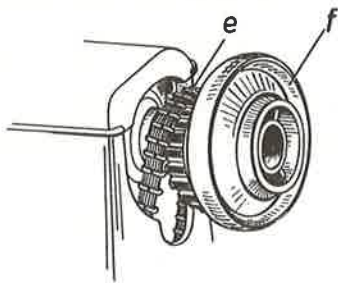

Figure 119

Figure 120



Zig zag sewing.

Zig zag stitching is performed when a machine is equipped with a swing-needle bar instead of the rigid bar found on straight sewing machines.

In addition to sewing straight, the needle bar moves sidewise.

Some of the adjustments have been covered by previous text. This text will cover principle and delve deeper into correction procedure.

To swing sidewise, the needle bar is attached to a frame which is pinned to the upper portion of face assembly.

A connecting bar moves needle bar when control F, fig. 121 is activated.

The stitch width control lever determines amount of sidewise motion. Maximum width differs with various manufacturers.

The Pfaff is 3/16". Control in the figure 121 is for model 260-360.

Pfaff 130 is covered in later text.

Needle position lever(B) differs a little from machine to machine. The dial shown in figure 122 is for Pfaff 230.

Figure 124 shows result of needle position change and stitch change in each position.

When the dial A is on 0 and dial B on 2, the machine is a straight sew.

Move dial B to 1 or 3 and machine still sews straight, but from a different needle position.

Move lever F and zig zag is activated.

Set dial A on any number past 0 and machine sews a zig zag stitch.

Bigger number makes wider zig zag.

Figure 121

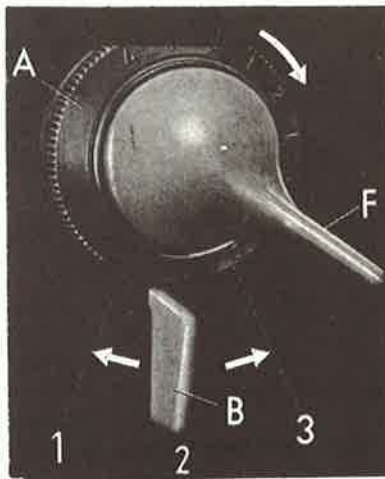

Figure 122

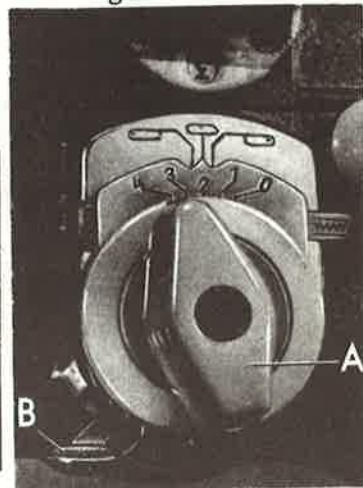

Figure 123
Left

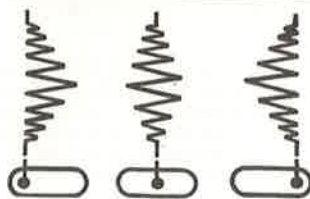
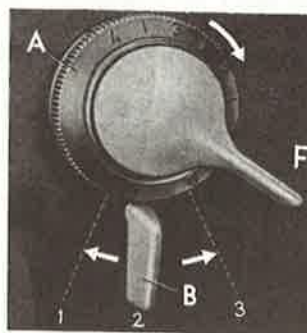
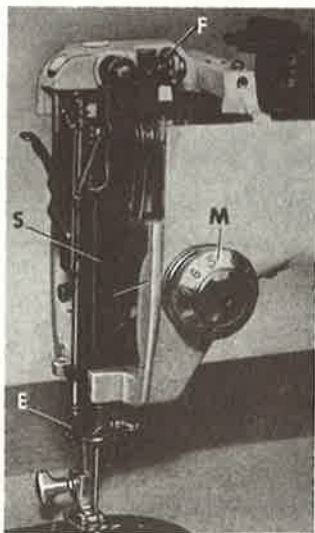

Figure 124
Right

Zig zag sewing.

Zig zag stitching is performed when a machine is equipped with a swing-needle bar instead of the rigid bar found on straight sewing machines.

In addition to sewing straight, the needle bar moves sidewise.

Some of the adjustments have been covered by previous text. This text will cover principle and delve deeper into correction procedure.

To swing sidewise, the needle bar is attached to a frame which is pinned to the upper portion of face assembly.

A connecting bar moves needle bar when control F, fig. 121 is activated.

The stitch width control lever determines amount of sidewise motion. Maximum width differs with various manufacturers.

The Pfaff is 3/16". Control in the figure 121 is for model 260-360.

Pfaff 130 is covered in later text.

Needle position lever(B) differs a little from machine to machine. The dial shown in figure 122 is for Pfaff 230.

Figure 124 shows result of needle position change and stitch change in each position.

When the dial A is on 0 and dial B on 2, the machine is a straight sew.

Move dial B to 1 or 3 and machine still sews straight, but from a different needle position.

Move lever F and zig zag is activated.

Set dial A on any number past 0 and machine sews a zig zag stitch.

Bigger number makes wider zig zag.

Figure 121

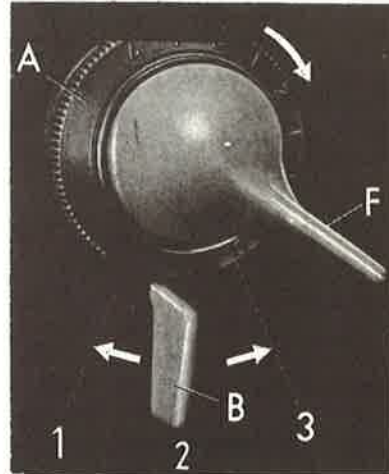

Figure 122

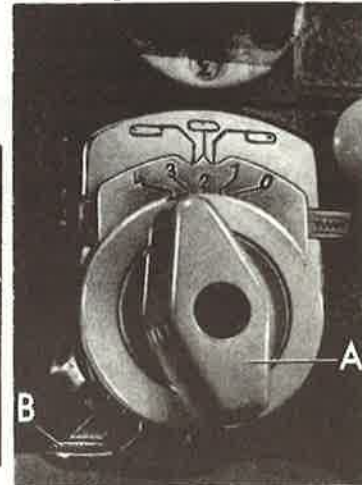

Figure 123
Left

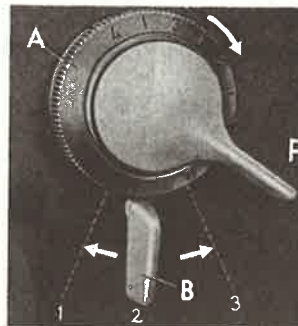
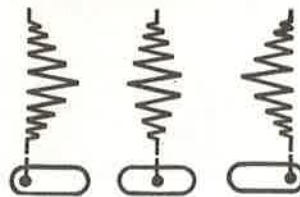
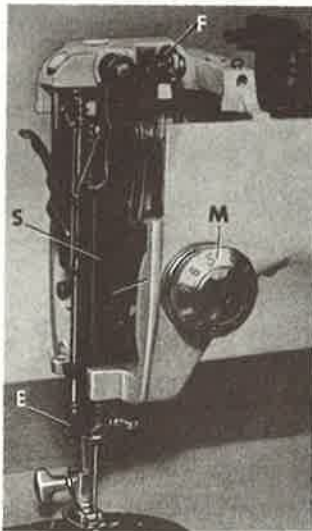

Figure 124
Right



There are many differences between the manual and automatic zig zag but the most prominent is the method of producing decorative stitches.

On the manual zig zag, the operator must move the individual control to create various different designs.

On the automatic, a mechanism is built in the machine which operates all controls automatically.

Figure 125 shows the mechanical principle of the automatic with built-in cam mechanism. The finger(2) rides cam(3) and activates connecting lever, which transmits throw of cam to regulator stud(5). The connecting link in slot of stud, transmits change to needle bar, which in turn makes the design.

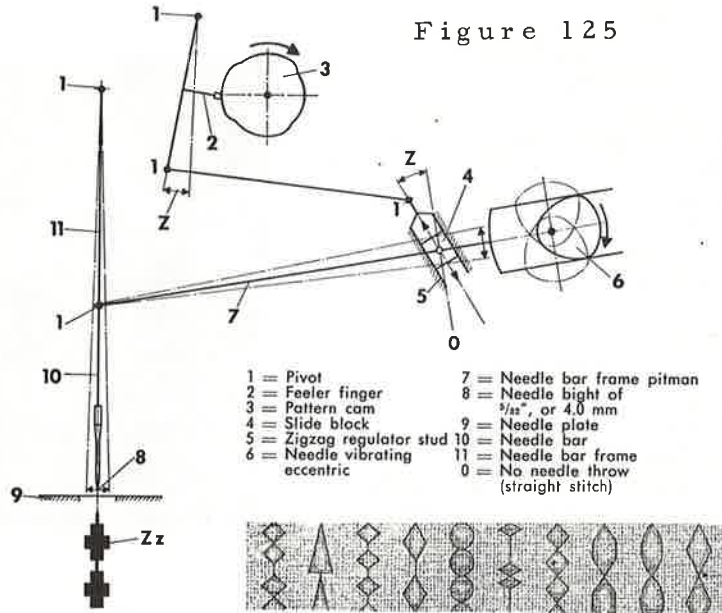
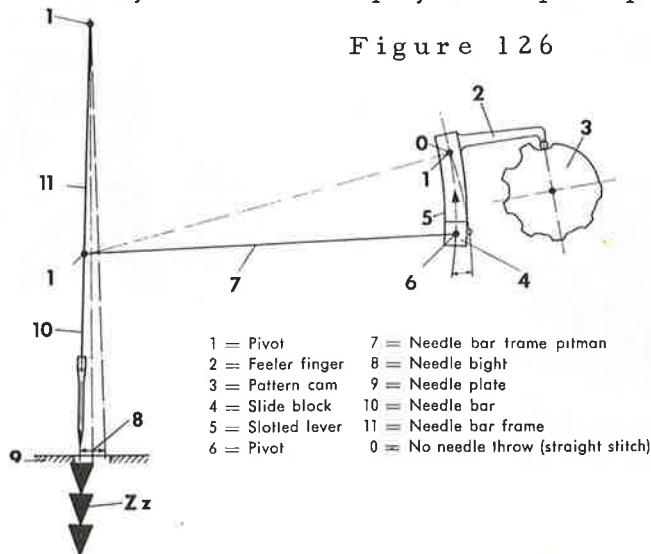
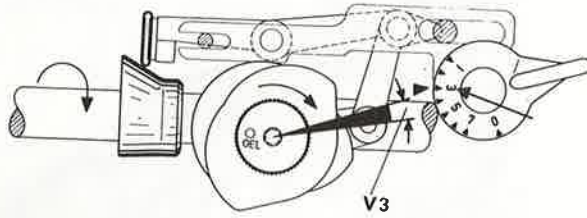
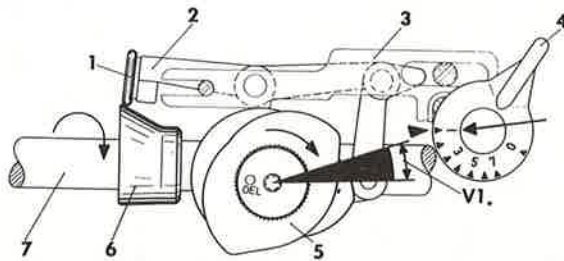
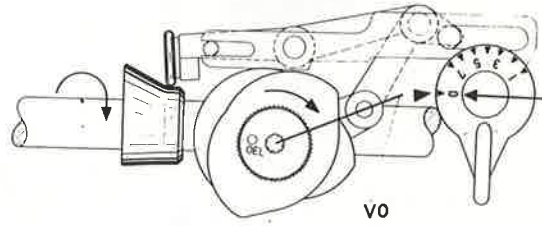

Figure 126 illustrates mechanical principal of automatic with drop-in-cam. The cam is changed each time a different design is desired. The basic difference is that both needle bar regulator and needle bar frame operate directly from pattern cam. Finger 2 is part of regulator and as finger traces the pattern over cam, it transmits motion directly to needle bar frame(11), via connecting link 7. Most early automatics employed this principle.



Driving eccentric system-Pfaff 260-360 machine

Figure 127



Zig zag and regulator mechanism for Pfaff 260-360.

Figure 128

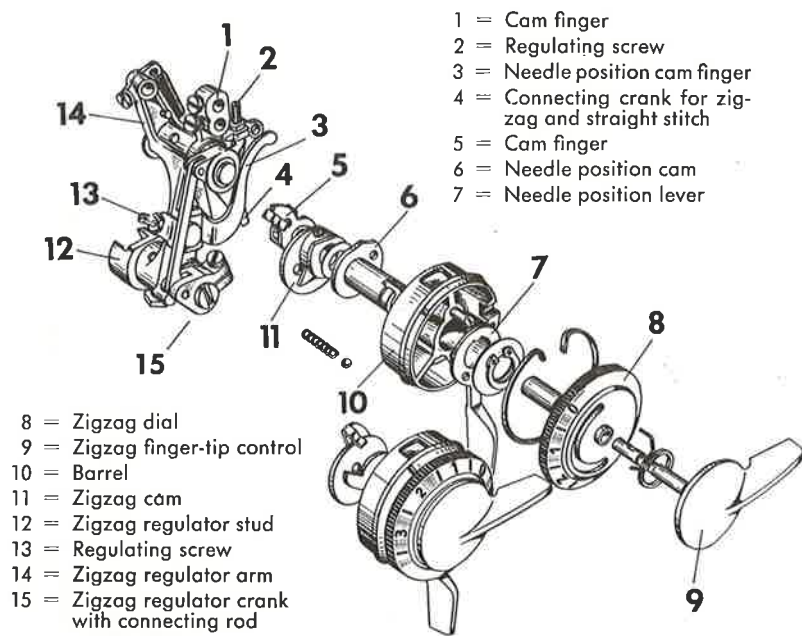
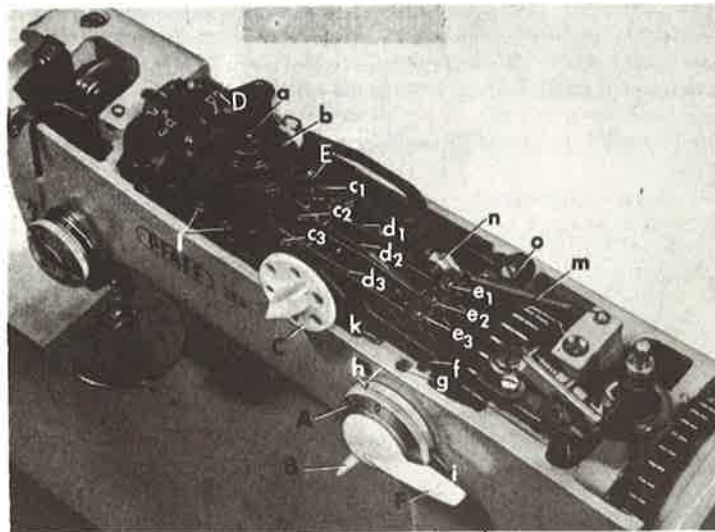

Figure 129



Principle and operation of Automatic Pfaff.

As mentioned earlier, the Pfaff utilizes the indirect mechanism control. The big advantage is versatility since needle position and stitch width can be varied at the same time or individually.

All patterns can be sewn in different lengths without altering the stitch density.

The motion begins as a result of eccentric motion from cam on the main shaft. The cam also acts as a collar to hold zig zag mechanism in place.

Roller cam is held against eccentric by a spring attached to the driving lever sidewise a set distance.

Sidewise motion determines cam assembly speed.

Regulating control varies the number of stitches per revolution. When set at 0, the drive roller comes back from eccentric to idle position, thus disengaging the automatic mechanism.

If end play is present in main shaft or automatic drive mechanism, the adjustment is made at the eccentric cam.

Figure 130, opposite, illustrates proper adjustment.

Loosen set screw and move cam toward front main bearing and needle bar crank from the front.

Leave enough room for oil to seep between.

Make sure main shaft doesn't bind when the set screw is tightened.

Caution: Never tap a balance wheel to loosen binding main shaft.

Bearings may be jarred loose and irreparable damage result.

At one point or another, every single moving part emanates from main shaft.

Exercise caution when adjusting.

When final adjustment is made on main shaft, a slight clearance must be preserved between balance wheel and rear main bearing.

Before replacing top cover, oil all working parts.

Run machine slowly, observe parts in motion.

Engage the levers and notice their reaction as machine runs.

If all parts move smoothly and the machine operates properly, tighten all screws.

Button down the top cover.

Any machine that operates on the same principle as the Pfaff can be adjusted from this text.

Figure 130

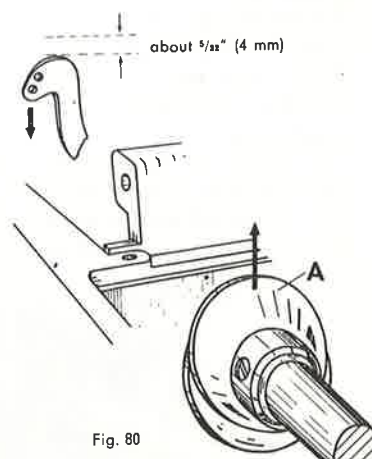

Fig. 80

The zig zag regulator mechanism on the Pfaff 260/360 is a unitized body, as is the automatic mechanism.

To remove automatic mechanism, proceed as follows.

1. Disconnect tension screw from regulating arm and unscrew pressure spring assembly 0.
Remove screws from base and loft mechanism out. Don't force it. If it hangs up, recheck procedure until error is discovered.
Dial A is on 4, loosen set screws holding the three engaging lever eccentrics.
Remove stud from rear lever(d-1).
Reset dial A to 0, to remove levers(d-2 and d-3).
2. Replace in reverse order.
3. To remove regulator mechanism, turn dial A to 0.
Set needle position lever in center slot and loosen set screw directly above it.
Remove top plate.
Push control lever F up. Move stitch width regulator to a left position while turning mechanism barrel slightly to the right.
Ease the barrel out of hole without force.
4. To replace, reverse the procedure. To reset properly, make slight mark where red mark appears on regular barrel.
Notch the head slightly, it saves a lot of guesswork.
5. Needle position B should point down from central position, when set properly.
The lobe of eccentric stud(B) should point toward the balance wheel, and needle bar pitman should be in extreme right position.
The lobe of eccentric cam(A) in needle bar frame will point upward.
Diagrams referred to are figures 128 and 129 on page 112.

Figure 131

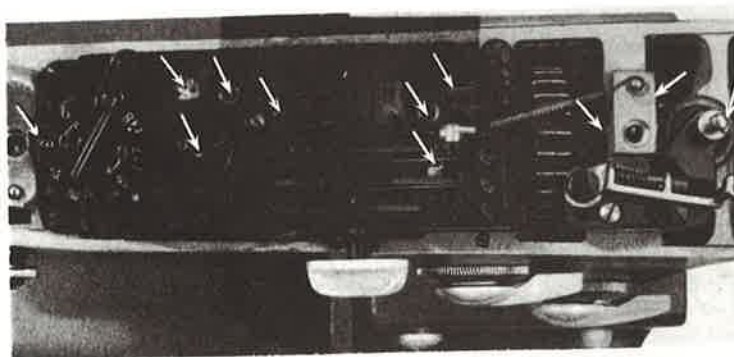

Checking the automatic mechanism.

After replacing mechanism, machine can be tested on several patterns.

1. Use setting D3-C2-B left-E1
2. Use setting D7-C3-B left-E1
3. Use setting D4-C5-B left-E1

Remove top, run machine slowly and observe mechanism.

When width changes from 0 to 4 and back again, there shouldn't be a bind.

Top thread shouldn't break.

Replace top cover and test sew.

Oiling the machine.

When servicing the Pfaff, or any machine, oil thoroughly.

If user, lubricate your machine at least once a month.

Figure 132

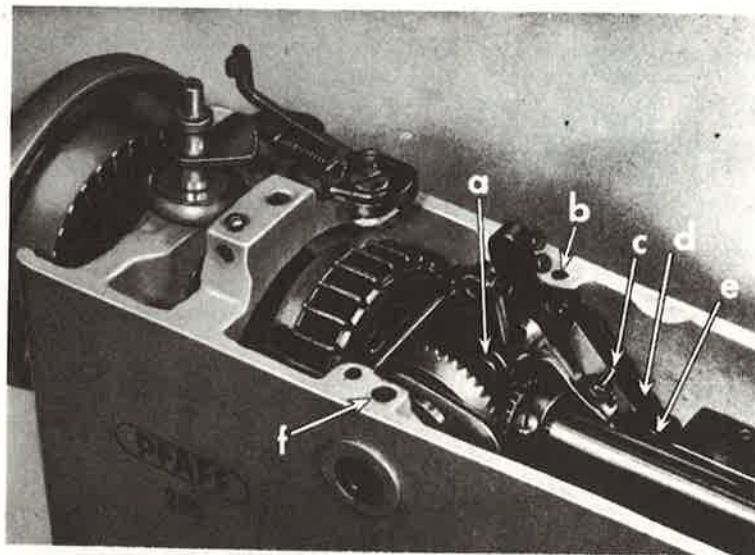

Skeleton of the Pfaff automatic illustrating mechanism.

- | | |
|--|--------------------------------------|
| 1 = Pressure regulating screw | 9 = Hook shaft with helical gear |
| 2 = Needle bar crank (driving needle bar and take-up mechanisms) | 10 = Hook drive shaft helical gear |
| 3 = Needle bar connecting link | 11 = Hook with bobbin case |
| 4 = Needle bar frame | 12 = Center for shafts 17 and 38 |
| 5 = Threader bar | 13 = Bobbin case position finger |
| 6 = Needle bar | 14 = Feed bar |
| 7 = Needle holder | 15 = Feed lifting shaft crank, front |
| 8 = Presser foot | 16 = Hook drive shaft |
| | 17 = Feed lifting shaft |

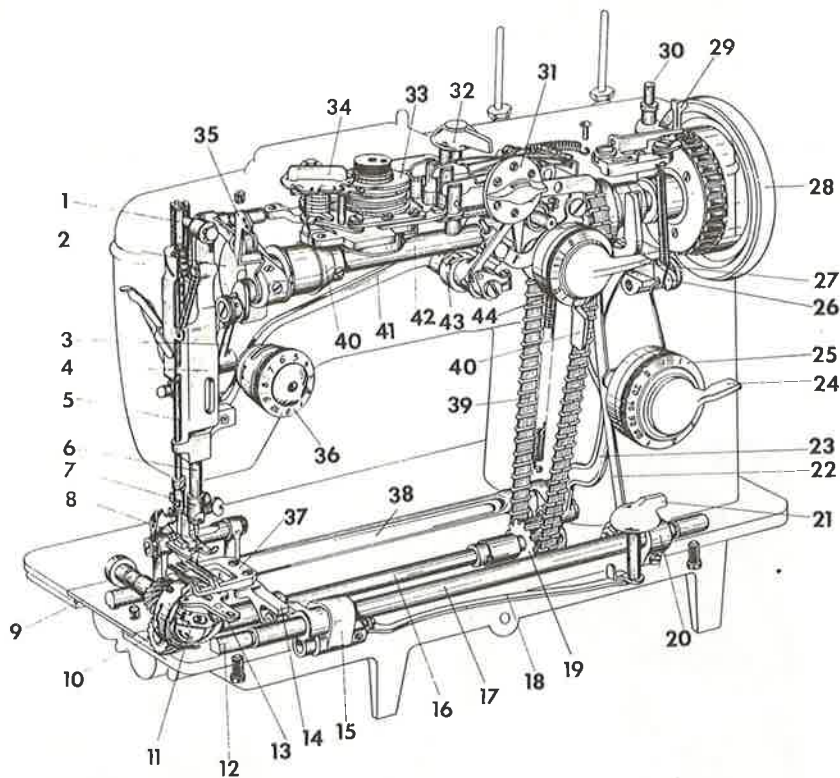

- | | |
|-------------------------------------|---|
| 18 = Drop feed connecting rod | 33 = Cam assembly |
| 19 = Driving belt sprocket, lower | 34 = Cam selector dial D |
| 20 = Feed lifting shaft crank, rear | 35 = Take-up lever |
| 21 = Drop feed knob | 36 = Tension dial M |
| 22 = Feed lifting connection | 37 = Feed dog |
| 23 = Feed forked connection | 38 = Feed rock shaft |
| 24 = Reverse feed control H | 39 = Driving belt (cord) |
| 25 = Stitch length dial G | 40 = Driving eccentric for automatic embroidery mechanism |
| 26 = Feed regulator | 41 = Needle bar frame pitman |
| 27 = Zigzag finger-tip control F | 42 = Arm shaft |
| 28 = Balance wheel | 43 = Zigzag regulator slud |
| 29 = Bobbin winder thumb lever | 44 = Stitch width dial A |
| 30 = Bobbin winder spindle | 45 = Needle position lever B |
| 31 = Engaging lever dial C | |
| 32 = Pattern length lever E | |

Pfaff 130.

Although the Pfaff 130 is not an automatic, it will be covered here due to similarity in design and operation.

Most adjustments have been covered.

The service procedure in following text is unique to the 130 alone.

Upper tension and check spring adjustment.

The tension dial on a Pfaff 130 is not calibrated.

To adjust, turn clockwise for more upper tension, counterclockwise for less.

The components are basically the same as previous models covered.

Check spring adjustment on the Pfaff 130 can be made without removing, or disassembling the tension assembly.

Lever (figure 134) can be changed to compensate for different materials.

Position A, or up, is for fine material and embroidery work.

Position B, or center, is for regular sewing, especially straight stitch.

Position C, or down, is for heavy sewing.

The check spring tension is increased as lever is depressed.

So much for the school of thought that check spring doesn't effect tension and vice versa.

Lower tension and hook assembly.

Adjusting tension on the 130 bobbin case is similiar to machines already covered.

For more lower tension, turn screw (A), figure 135, clockwise as needed to correct.

For less lower tension, turn screw counterclockwise as needed.

If case tension spring is thread cut, loosen screw (A) and replace.

If lower thread breaks constantly, probable causes are:

1. Lower tension too tight. Loosen as needed to correct.
2. Dirt or lint in case. Clean as needed.
3. Bobbin bent or scarred. Throw it away, replace with new one.
4. Case incorrectly threaded. See figure 135.
5. Case inserted wrong. Hold latch until case is on spindle.
6. Bent bobbin case. Replace with a new one.

Figure 134

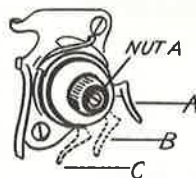
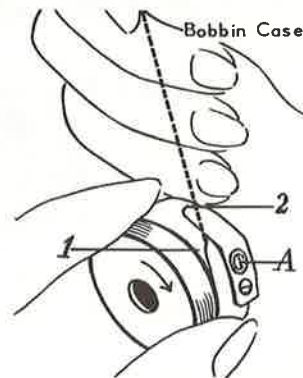

Figure 135



To time the hook with needle bar, set needle bar position in slot 2.
 Set zig zag control on 0.
 Turn balance wheel until needle barely shows on downstroke, figure 136.
 Hook point should point at 3 o'clock, if not, adjust as follows.
 If hook point is above mark, loosen three screws and turn down.
 If hook point is below mark, timing is slow and must be moved up.
 Tighten set screws and test sew.
 Clearance between needle should remain at .004.
 When tightening the three screws on hook, be sure of tolerance.

Disassembling the hook.

Remove holder finger (basket stop).
 Loosen three screws on cast-off gib.
 Turn balance wheel until cutter edge comes into open area.
 Lift out bobbin case holder.
 Loosen three screws holding hook and remove.
 If hook point is broken, replace. Don't attempt rebuilding it.
 If numerous needle strikes show on outer shield, retime machine.
 Re-assemble in reverse order.
 Be sure timing and needle point/hook tolerance are accurate.
 Allow enough space between holder finger and bobbin case holder for the large size thread to slip by without hanging up.
 If hook shaft binds, adjust as follows:
 Tap end of shaft until free play is present.
 Turn balance wheel several times (with hook removed) until running free.
 Tighten both screws on set-ring.
 Grease gear box frequently. Use a high viscosity grease or vasoline.

Figure 136

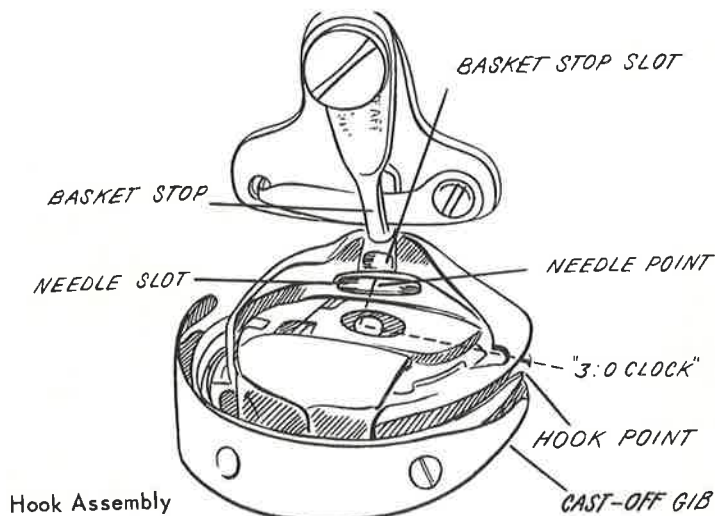

Needle bar adjustment.

- To time the needle bar for proper height, set position lever in center.
- Set zig zag control on 0.
- Turn balance wheel until needle is at lowest point.
- Recheck needle position in needle clamp, or insert a new needle.
- Clearance should be 1/8" above bobbin case opening.
- Insert screwdriver through needle bar frame (figure 137) and loosen the set screw on needle bar clamp and set to correct height.
- After making sure needle bar is properly aligned, tighten set screw.
- To adjust needle bar for proper zig zag motion, turn dial to 4.
- Turn balance wheel until needle bar descends on right and left side of needle plate.
- Check clearance between needle and needle slot on each side.
- If incorrect, loosen set screw in needle bar frame.
- Turn eccentric cam pin proper direction until clearance is equal.
- Tighten the set screw. (screw is accessible through hole in rear cast.

Timing the zig zag.

- Turn zig zag dial to 4.
- Turn balance wheel and observe needle bar descent and upper cycle.
- If bar doesn't cycle at upper-most position, adjust as follows:
 1. Remove arm plate.
 2. Loosen two set screws on eccentric bearing ring. Remove ring.
 3. Move gears until grooves are aligned.
 4. Mark on eccentric gear should be at 3 o'clock.
 5. Move gears apart, turn balance wheel until marks coincide.
 6. Re-engage gears, replace bearing set ring with oil hole up.
 7. Tighten all set screws, replace arm plate.
 8. Check and test sew.

Adjusting height of presser bar.

- Remove face plate.
- Raise presser bar.
- Proper clearance is 1/4" between presser foot and needle plate.
- Loosen presser bar set screw.
- Adjust to proper height.
- Be sure needle clamp doesn't hit.
- Tighten set screw.
- Hold presser bar firmly. If not aligned, needle may strike foot.
- To adjust pressure on cloth, adjust bar pressure screw.
- For more pressure, turn down.
- For less, turn up.
- On models with patcho, push button as needed.
- If tension doesn't release when the lifter is raised, bend release lever.
- If problem is in tension, remove.
- Check pin and release washer.
- If tension remains released when lever is down, bend lever back.

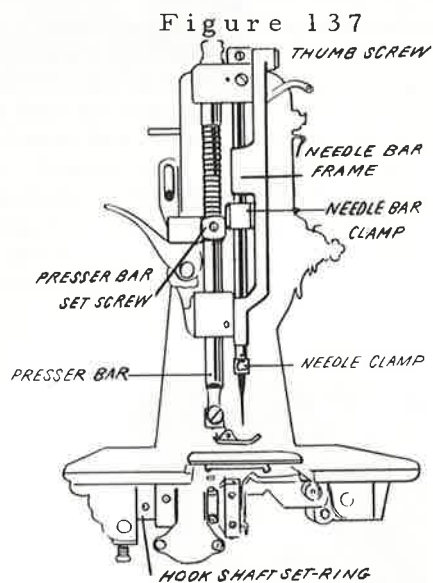

Adjusting the feed dog.

Turn balance wheel until feed dog is at highest point.
 Proper height is 1/32" above level of needle plate.
 If adjustment needed, loosen set screw on rocker arm of feed bar.
 Turn feed bar until teeth appear at proper height above needle plate.
 Tighten set screw and test.

Figure 138

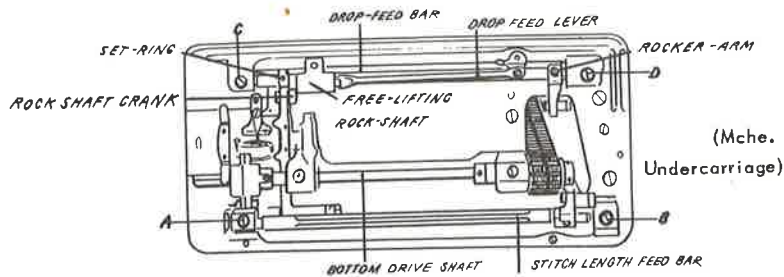

To adjust proper length of stitch, set stitch regulator on 0.
 Loosen screws on stitch regulator fork clamp.
 Move feed dog manually until centered in needle plate slots.
 Tighten screws and test sew. Feed dog should rise and fall in place.
 To time feed motion, set stitch regulator on 0.
 Loosen both set screws on the feed cam.
 Hold cam firmly and turn balance wheel toward you.
 When the needle bar and feed dog are both at highest point, tighten screw.

Adjusting zig zag control.

Place position lever in slot 2.
 Turn zig zag control dial to 0, and hold firmly in place.
 Loosen pointer set screw. (screw G).
 Run machine at a medium speed.
 Insert screwdriver in slot of control dial. Loosen set screw. (a).
 Turn right or left and observe needle path.
 When needle moves straight up and down, tighten set screw.
 If control dial is too loose and won't hold a setting, adjust as follows.

1. Loosen set screw and adjust. Hold firmly in place and tighten.
2. Remove face plate and loosen set screw on needle bar frame.
3. Tap upper needle bar frame gently and align as needed.
4. Tighten set screw, replace face plate and check.

If complete dial is too tight and moves hard, loosen set screw slightly.

Figure 139

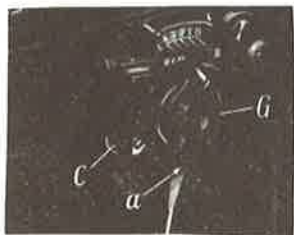
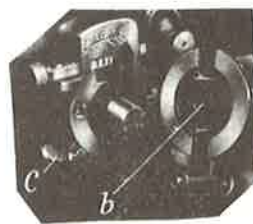

Figure 140



The Viking Automatic.

The Viking is manufactured by Husqvarna Corporation in Sweden. Famous throughout the World for excellent gun works, their sewing machine is one of the finest on the market.

The Viking 21 through latest model 6000 series is a free arm automatic portable which converts to a flat bed by using an adaptable plate.

The model 21 is a cam stack automatic with each stack containing five different designs.

Later model utilizes what the company calls its "Colorcode" system. To choose decorative design user wishes, she merely checks color, then uses that color cam.

The service and repair guide will cover (with minor differences) model 20, 2000, 6000, 19, 8E, modified 21's and flat bed 51 machines.

Where necessary the Viking 33 and straight 12 will be alluded to.

The model 12 is a class 15 machine with link take-up. Refer to Chap. 2.

The Viking 33 closely resembles the Pfaff, both in operation and service and can be repaired from text earlier in this chapter.

Figure 141

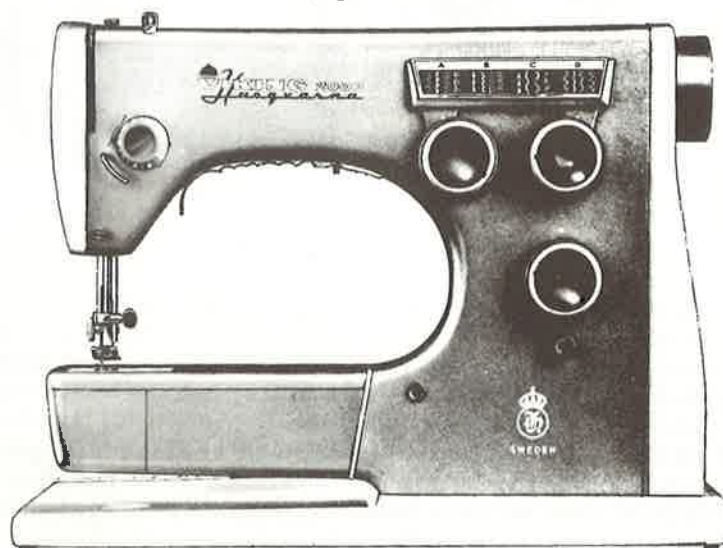

The tension assembly, as on most modern machines, is unitized.

After the face plate has been opened, loosen set screw and entire assembly may be removed.

Figure 142 shows older unit that was used on model 20, 21 and 51.

Regulating dial is numbered from 1 to 3 and corresponds with a series of rings around adjusting nut.

Adjustment is quite simple. When bobbin case tension is set, turn knob inward until second line matches the disc guard. This is proper tension for regular sewing. For loose top tension turn out to line 3.

Tension assembly

Figure 142

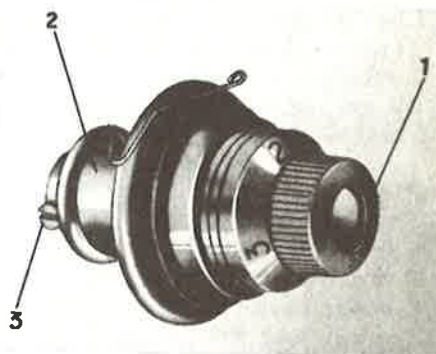

Tension assembly-later model Viking free arm.

Figure 143

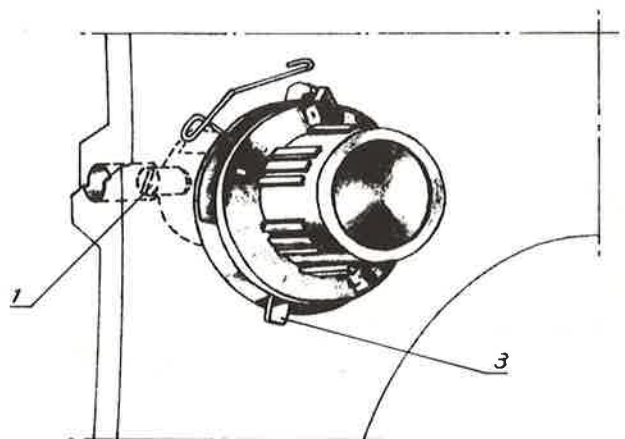
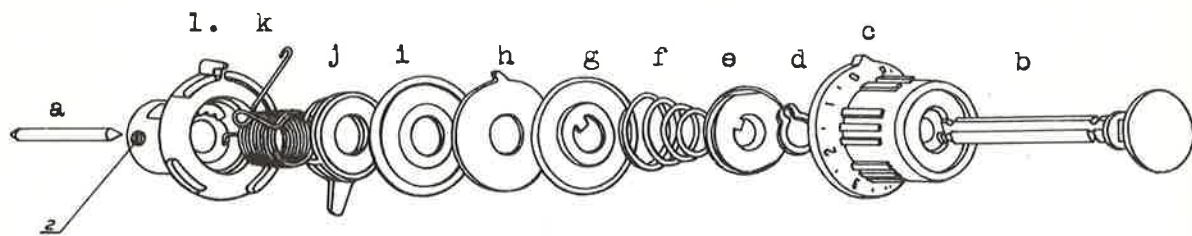

To remove for adjustment, loosen screw (1) and pull out.

Remove thread release pin(a)

Loosen set screw(2) on barrel, and pull out stud and control knob.

Slip out discs(g-h-i) and turn stud to right until nut is loose.

1. If tension discs are thread cut, replace them.
2. Broken or badly bent check spring must be replaced. (page 123).
3. If tension doesn't release properly, check release pin(a). If too short, replace it, but be sure tension assembly is against machine head when set screw is tightened.

To re-assemble, reverse procedure.

Check spring is in center position when adjusting ring(j) is against it.

Adjusting handle(3) must be down.

Hold tension stud(b) and replace control knob(c), in place.

Lock washer(d), tension spring holder and spring(e and f), are next.

Tension discs go together with embossed side away from each other.

Center disc goes on with finger pointing up and toward the machine.

Finger should be opposite 0 on adjusting dial.

Entire assembly fits into check spring and then into the barrel.

Tighten screw(2) and replace assembly in head of machine.

Place assembly in position shown in figure 143 and tighten screw(1).

Test sew and adjust tension as needed.

For more upper tension, turn dial clockwise as needed.

For less upper tension, turn dial counterclockwise.

Always make tension adjustment in small increments.

For zig zag stitching, loosen top tension slightly.

Check Spring adjustment, old style.

To adjust the check spring on a model 20, 21 or 51, loosen set screw(1), and remove tension assembly.

Test sew to determine which adjustment is required. If check spring doesn't release thread as needle enters the cloth, spring is out of adjustment.

1. When check spring releases the thread too soon, turn tension stud, counterclockwise, 1/4" turn, or as needed.
Tighten set screw, replace tension barrel in machine and test sew.
2. If check spring holds thread until it's in material, reverse the procedure. Turn tension stud clockwise as needed.
Replace tension barrel and test sew.

Figure 144

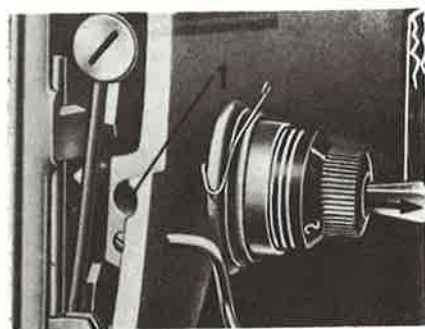
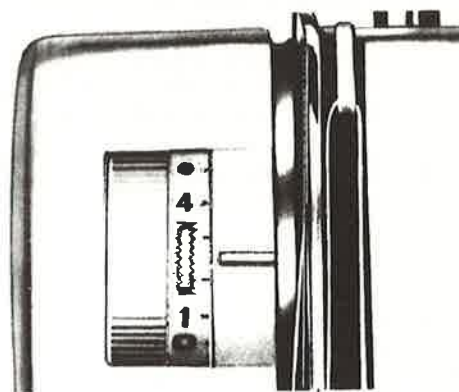

Figure 145



Check spring adjustment, new style.

Check spring adjustment on the new style Viking has been greatly simplified. Unless the machine is several years old, or the machine has been a bent check spring, the proper position may be attained by placing adjusting lever(j), figure 143, in center position.

As machine wears with age, advance lever clockwise to compensate for wear.

If machine has too much throw, retard lever a notch, or as needed.

When making a tension or check spring adjustment, always tighten screws securely and be sure tension barrel is flush against machine head.

Never force a screw, if it's balky, pour a drop or two of penetrating oil in general area and let it soak.

Tension adjustment on series 6000.

The tension assembly on 6000 series is enclosed and represents a novel advancement in the sewing machine industry.

Adjustment dial is knurled and protrudes toward operator.

Graduation is from 0 to 10, with a special mark for regular sewing, and a special setting for buttonhole work. (Buttonhole stitch must be somewhat tighter than regular sewing). See figure 145.

Except for regulating knob, the tension is internal and accessible through face plate door.

Lower tension.

The lower tension should be adjusted to make a good lock stitch with very little tension.

To remove bobbin case, lower front access door and remove toward you.

1. If upper tension is properly adjusted and thread pulls through cloth, loosen bobbin thread. Turn screw(2) counterclockwise as needed.
2. If lower thread is pulled up through material, opposite is true. Turn screw(2) clockwise, 1/4 turn or as needed.
3. If neither of first two adjustments remedy situation, remove spring. If tension spring is thread cut, replace it. If lint and dust have accumulated under spring, clean it. Check case for damage. If bent or scarred, replace it. If bobbin case keeps falling out and distorting tension, replace latch.
 - a. Check spring latch and hook spindle. If dust or lint have gathered in latch, it may not hold. Check hook spindle for bits of thread, remove at once. Bobbin case must be latched securely to insure good tension. Check area for needle strikes. Smooth with emery cloth.
 - b. Check the bobbin for needle strikes. If bobbin is needle scarred, destroy it and replace with new one. Thread passes over bobbin on every stitch.
 - c. Oil hook spindle before test sewing.

Replace the bobbin case.

Thread machine and test sew while observing through opened door.

If threads pass smoothly and lock properly in material, adjustment completed and corrected.

Figure 146

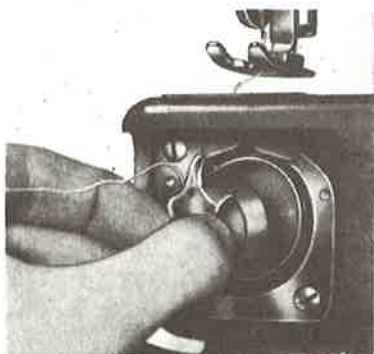
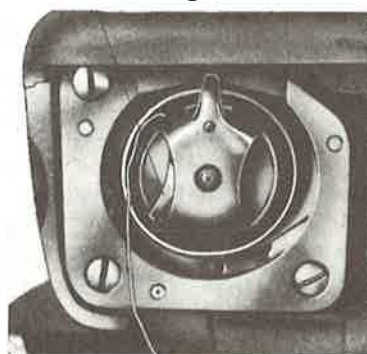

Figure 147



Timing and adjusting the hook.

When the sewing machine breaks needles, the first place to check is the needle plate. Many operators still have a habit of pulling material even though machines all have elaborate feed systems.

If this is the case, advise the user to let machine do the work, and go on about your business. If not, remove the needle plate and check lower sewing mechanism.

Check sewing hook.

If there are needle strikes on or near the sewing hook, remove hook and smooth area with emery cloth. See figure 152 for procedure.

Needle strikes on hook or immediate area indicate the machine is out of time.

If the machine skips stitches or doesn't bring up the lower thread, it's probably out of time.

Before making the final analysis, replace existing needle with a new one. Exercise extreme caution and place in needle clamp properly.

More users have spent countless dollars to have a needle placed properly than any other single adjustment or malfunction.

After above procedure has been followed and machine still malfunctions, proceed with timing adjustment.

Timing the hook.

Set zig zag dial on 0, and needle position lever in center position.

Remove lower cover plate and free arm cover.

Rest machine on its back, turn balance wheel until each of three screws is exposed. (Screw 1, figure 149).

Loosen each screw and turn balance wheel until needle reaches lowest point. Bring wheel around until needle rises .098" and observe relation to the point of hook.

Hold hook securely in driver, with hook in slot. Press firmly to eliminate any play between the two parts.

Turn hook and driver until point of hook is in line with needle. (figure 150)

Tighten one of set screws (1, figure 149) and recheck timing by threading machine and observing as hook enters the loop.

If hook catches thread each time, tighten other two screws and re-assemble other components. Tighten all screws securely and test sew.

Figure 149

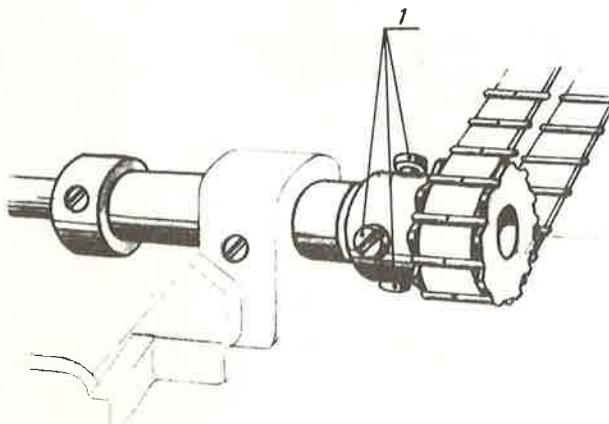
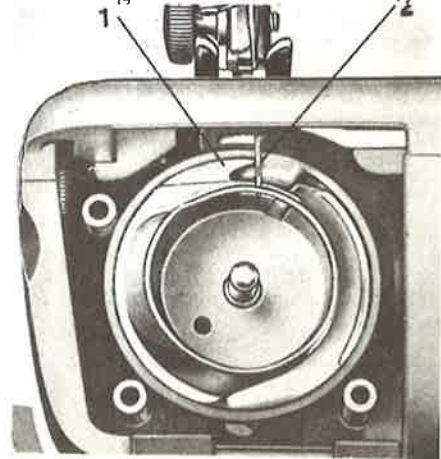

Figure 150



Setting clearance between hook and race cover.

Loosen set screws(1, 2 and 3) and remove cover(4). Figure 150.
 Loosen holder screws(5) and move holders proper direction to correct.
 Clearance between hook and needle scarf should be .0039".
 Adjust holders by pushing inward with finger tips against shoulder screw.
 Hook and cover are in place, continue pressing until screws touch cover.
 Lock holders in place(1 and 3). Adjust holder 2 last.
 Avoid play by pressing at point 4, which automatically adjusts holder 2 in
 correct position.
 Tighten the lock screw.
 Proper clearance should be .0157".
 Check adjustment by turning balance wheel a few turns. It shouldn't bind.
 If there is a slight bind, back holders off slightly and re-check.
 Re-check needle clearance per figure 151.

Figure 150

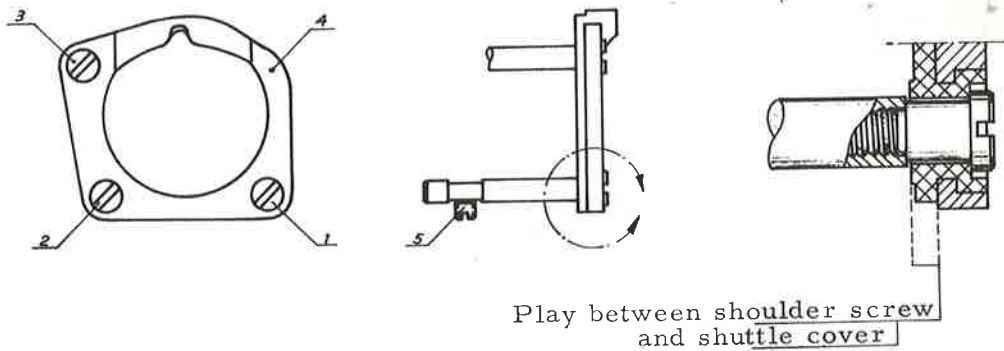

Setting clearance between hook and needle.

Remove free arm cover.
 Remove hook assembly and driver.
 Observe shims on drive shaft. If adjustment is closer to needle, add one
 or more shims as needed. If hook is too close, remove as needed.
 Re-assemble and test sew.

Figure 152

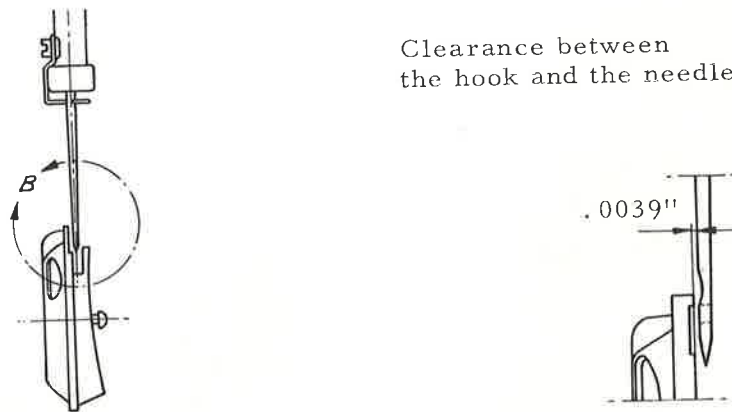

Diagrams showing relation of hook/needle in timing.

For test covering the following illustrations, refer to pages 124-126.

Figure 153

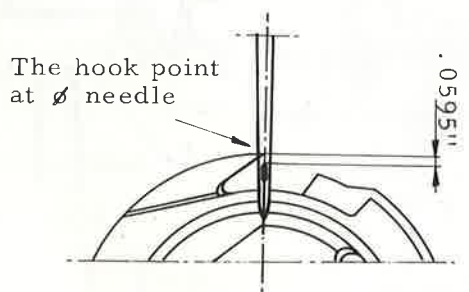
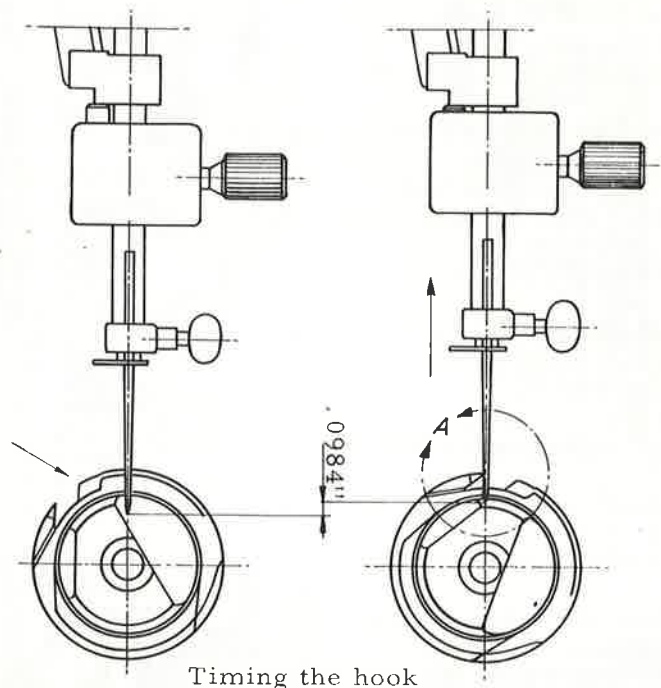

Setting the needle bar height

Timing the needle bar.

Set machine for straight sewing and turn balance wheel until needle reaches lowest point.

Point of hook should be in line with center of needle.

Open face cover and loosen screw(1). Adjust needle bar until top of needle eye is .059 below point of hook. See figure 153, page 127.

Check clearance, when correct, tighten set screw.

Hold needle bar firmly so it doesn't turn while adjustment is made.

Eye of needle must face the front.

Flat side of needle goes to back.

Face plate assembly.

Figure 154 shows components and relation to each other.

Needle bar and spring(a).

Take-up arm(b).

Tension and check spring assembly(c)

Presser bar(d).

Lifter(g), adjusting block(h) and release block(i).

The main cam is visible behind other components.

The swinging face plate door makes service much simpler.

Later model 6000 series have the tension assembly, built in face plate.

Adjusting needle bar frame.

Set zig zag lever on 4.

Turn balance wheel until needle is at extreme left position.

Lower needle slowly until needle reaches needle plate.

If needle strikes plate, adjust screw (2), figure 155, with allen wrench until adjustment is complete.

Turn balance wheel slowly when lowering needle for this adjustment.

Make one complete revolution so the machine is on proper stroke.

To check further, activate the pattern selector and observe needle path.

Check set screw(3). Be sure spring (1) is tight.

Test sew.

Figure 156 shows top view of bar.

Figure 154

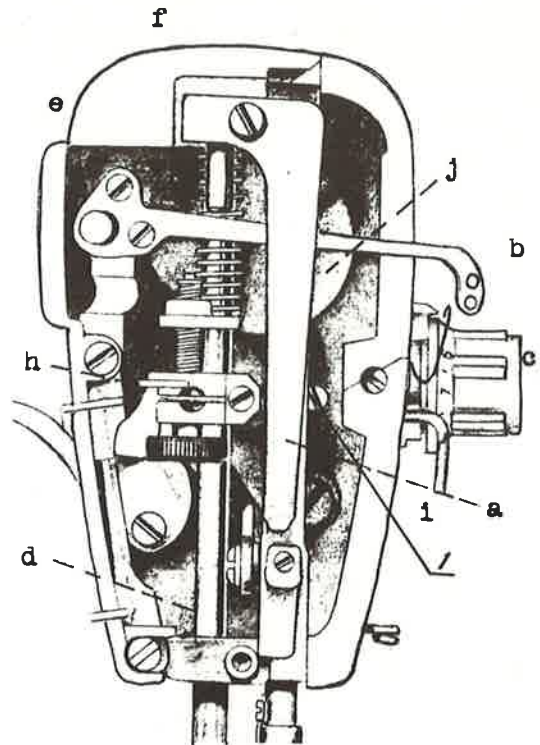

Figure 155

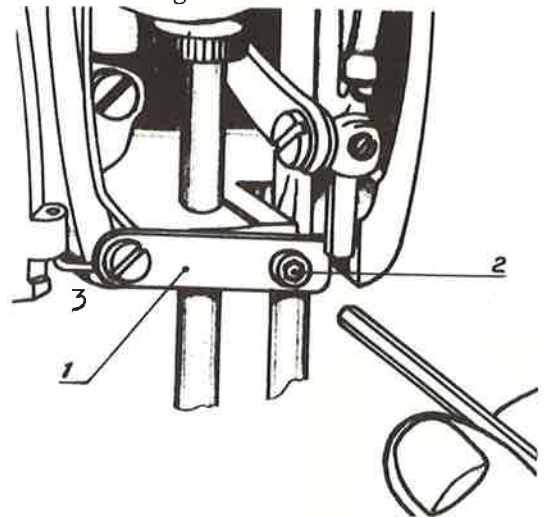
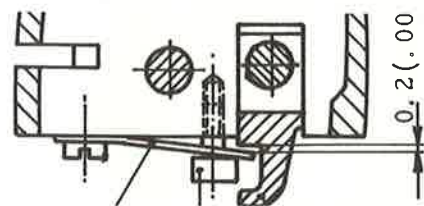

Figure 156



Centering needle in needle plate-zig zag.

- Set zig zag control knob on 4.
- Turn balance wheel until needle enters needle hole.
- Open face cover, loosen screw, (1) on needle bar frame.
- Observe path of needle descent, on right and left hand stroke.
- Return needle to left stroke.
- Lower needle to needle hole.
- Turn eccentric screw(2) until the needle enters hole at equal spots.
- Tighten set screw(1) and test.

Figure 158

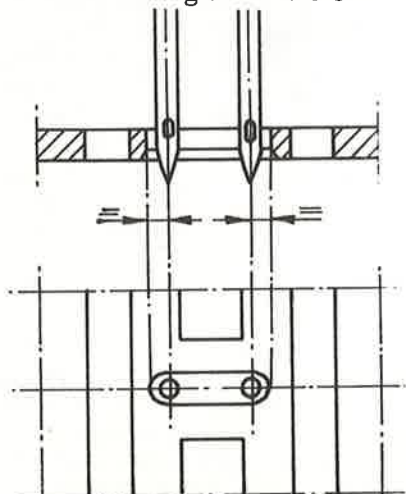

Centering front to rear.

- Loosen screw(1). Fig. 157
- Drop needle into hole.
- Set zig zag control on 0.
- Set position lever on center.
- Move needle bar frame as needed to correct.
- Tighten set screw and test.

Figure 160

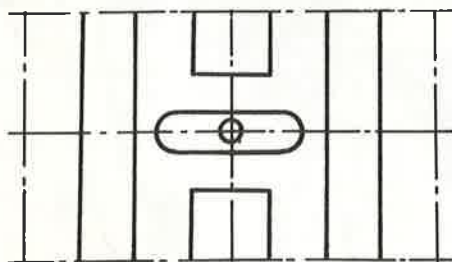

Figure 157

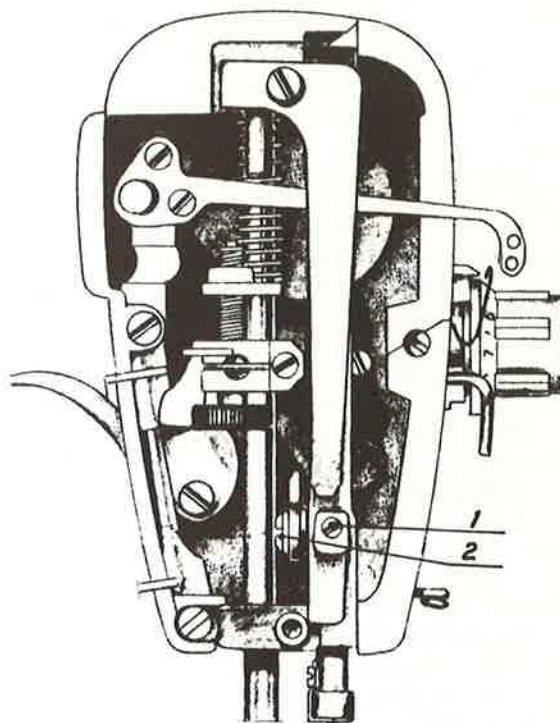
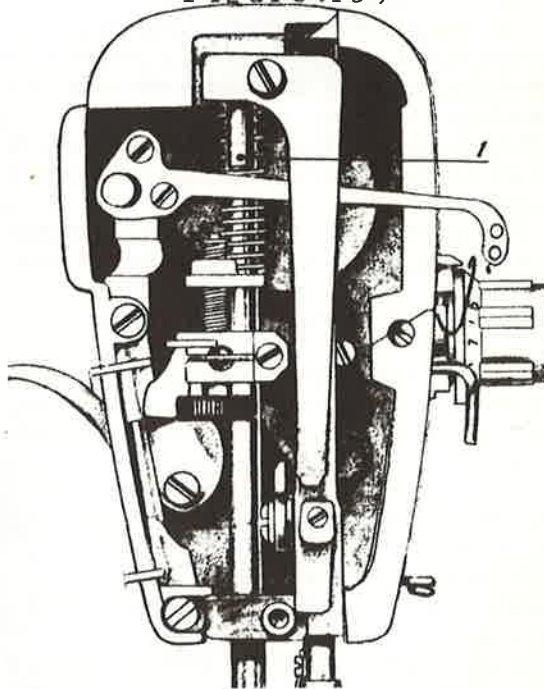

Figure 159



Presser bar.

Proper height of presser foot above needle plate is 1/4".

If user complains that cloth feeds unevenly, and feed dog is properly adjusted, check the presser bar.

Adjust spring(3) with knurled adjusting knob.

Check pressure by lowering presser foot on material with feed dog raised.

If foot doesn't hold cloth firmly, the presser bar must be lowered.

Few repairmen have access to a guage so correct height should be set at 1/4". Loosen set screw(1) and adjust presser bar as needed.

Feed dog must be in down position. Presser bar lifter should be in "UP" position.

Tighten set screw and test sew.

After setting is made, reset pressure for regular sewing.

Caution: Check alignment of foot in relation to needle hole.

Needle must clear presser foot when in zig zag position.

Needle clamp must not strike presser foot when it's raised.

Hold presser bar securely when set screw is tightened.

The knurled regulating screw may be turned down, releasing all pressure so machine may be used for darning and mending.

The free arm feature enables user to mend socks and trouser legs with equal ease.

The drop feed feature aids operator in mending, as well as other operations.

Tension release lever.

If user complains that thread doesn't release when presser foot is raised, the tension release lever may need adjusting.

Open face plate, lift presser bar lifter and observe relation of release lever to release pin.

If they don't make contact, turn eccentric screw(1), figure 162, until contact is made.

It isn't necessary to remove needle bar. Diagram is to show proper screw.

Figure 161

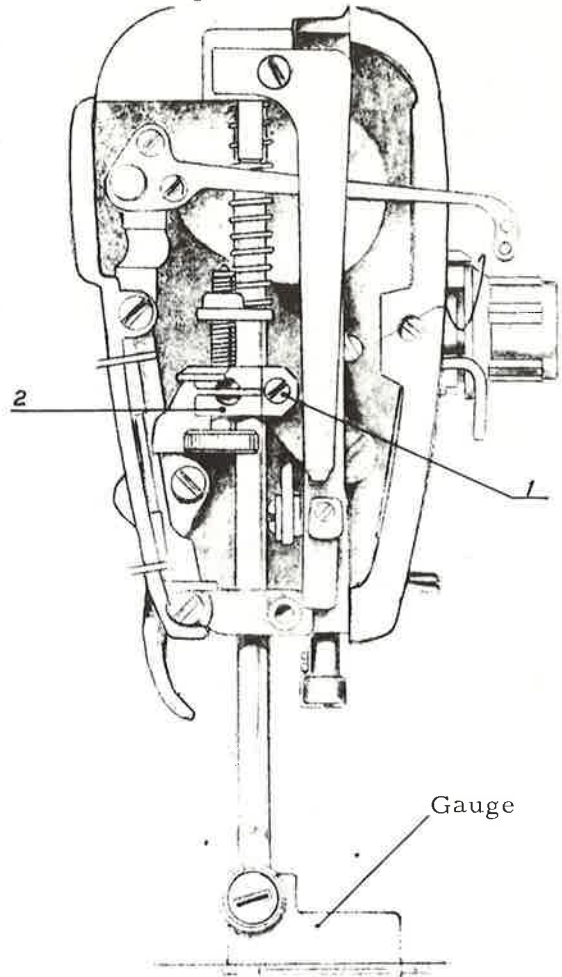
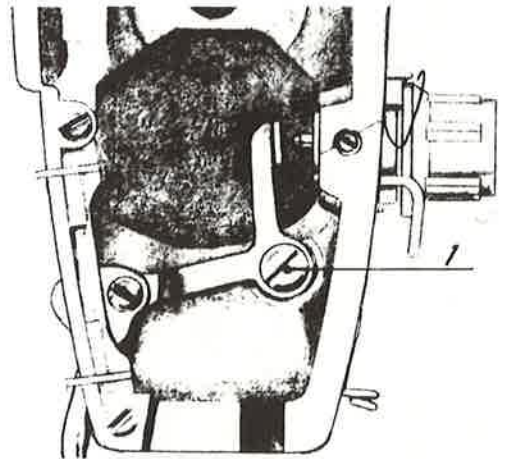

Figure 162



Feed dog.

If material doesn't move, or feeds erratically, and it's determined presser bar adjustment is correct, the feed dog should be adjusted.

Remove lower cover plate and free arm cover. Set stitch length control on 4 and turn balance wheel until feed dog is at its highest point.

The correct setting is $1/32$ " above needle plate when feed dog is at highest point.

If not, loosen set screw(1), move the feed dog to correct. See figure 163.

Tighten set screw.

Turn balance wheel and observe.

If feed dog motion seems consistent, tighten screw securely and replace the cover.

When feed dog strikes needle plate in slots, lateral adjustment is required.

Remove free arm cover.

Loosen screw(2), figure 164.

Move feed dog carrier proper direction to correct.

Snug screw(2), turn balance wheel and observe relation of feed dog and plate.

If corrected, tighten screw, replace free arm cover and test sew.

If feed dog strikes needle plate in end of slot, adjust as follows.

Remove free arm cover.

Set stitch length regulator on 4.

Loosen screw(1), figure 164, and set feed dog, manually, forward until clear and free.

Tighten set screw and turn balance wheel. If feed dog clears, replace all parts.

Test sew.

Figure 163

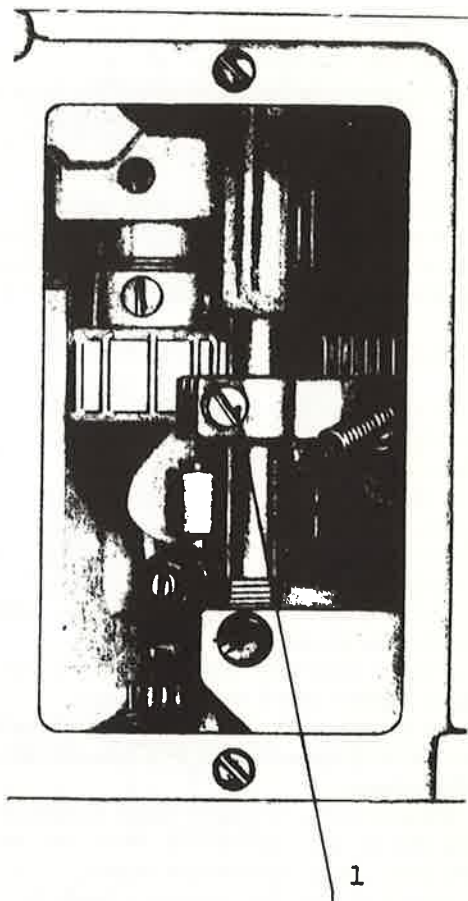
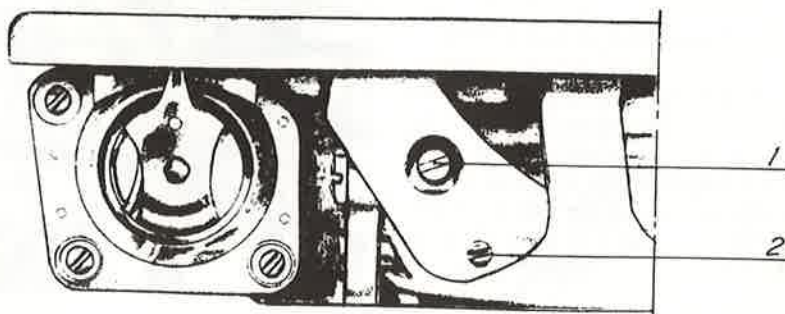

Figure 164



Feed Dog adjustment, model 20, 21 and 51

For lateral adjustment, loosen nut(4), figure 165, and nut at other end of feed rocker bar.

Free arm cover must be removed. Adjust tapered screw(5) opposite the direction from side feed dog is hitting.

Adjust as needed.

Tighten lock nuts.

For lengthwise adjustment, loosen set screw(2).

Move feed dog proper direction to correct.

Turn balance wheel and observe.

Feed dog should have maximum throw, without striking plate, when stitch length control is on 4.

Timing feed to needle bar.

In the sewing operation, the feed should be up, moving the material, when needle is at highest point.

If it doesn't, adjust as follows.

Set position lever in center.

Set zig zag control on 0 and the length of stitch control on 4.

Turn balance wheel until needle starts on downward stroke.

Press reverse button to find position where feed dog is inert.

At this point, the needle should be .472"(approx. 1/2") above needle plate.

To correct, loosen rear inspection plate and observe two set screws on feed eccentric cam.

Loosen the set screws and turn balance wheel until corrected.

Tighten set screws and replace inspection plate.

Test sew.

Caution; Tighten all set screws, securely, since even a slight vibration may loosen them and distort the entire sewing operation.

In many cases a loose screw will result in an expensive repair job.

The mechanic must be very careful. One free call back will take all the profit from a repair job.

Figure 165

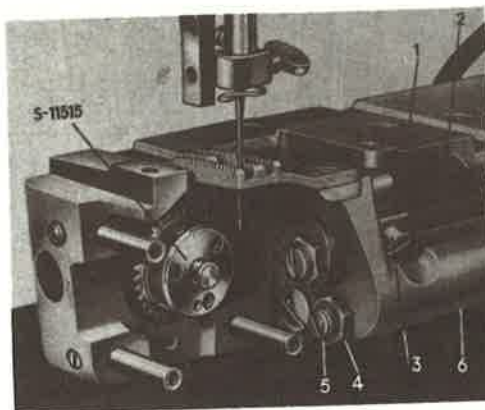
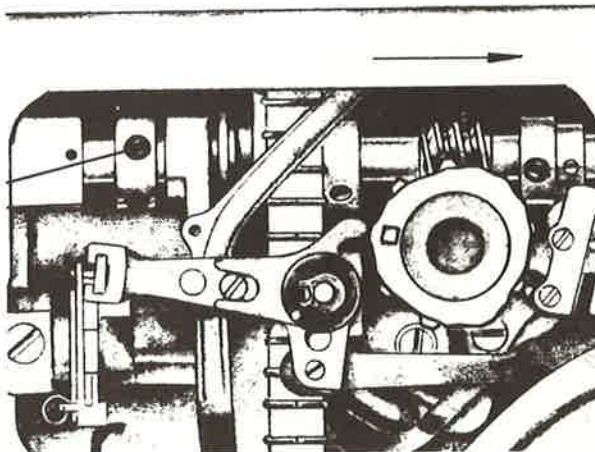
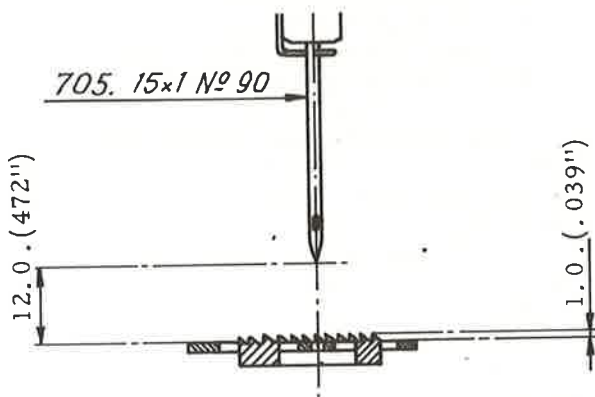

Figure 166



Adjustment for zig zag conformity.

On the model 21 and 51, set zig zag dial on 0.

Loosen set screw(2) on underside of dial. Figure 167.

Remove rear cover plate, figure 168, and move follower(4) until cam follower(1), figure 168, retracts from the camstack.

Tighten screw(2), figure 167.

The cam follower should leave camstack when dial is set on 0.

Figure 167

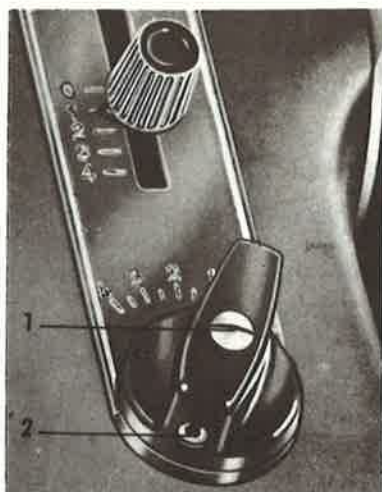

Figure 168

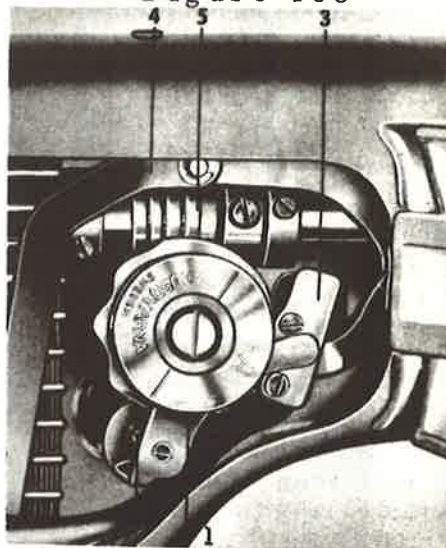

Figure 169

Needle position adjustment.

To set middle position, put zig zag dial on 0.

Turn balance wheel until needle enters needle plate.

Adjust eccentric screw(1), figure below, through rear inspection plate.

Turn screw until needle is centered. See figure 169.

To set left position, place business card under presser foot and set zig zag dial on 4.

Lower needle into cloth in left position.

Raise needle and return zig zag dial to 0.

Lower needle into card. If the needle doesn't enter card in exact spot, correct as follows.

Remove rear inspection plate and turn eccentric screw(2) until needle moves to proper place.

Test sew.

Figure 170-opposite.

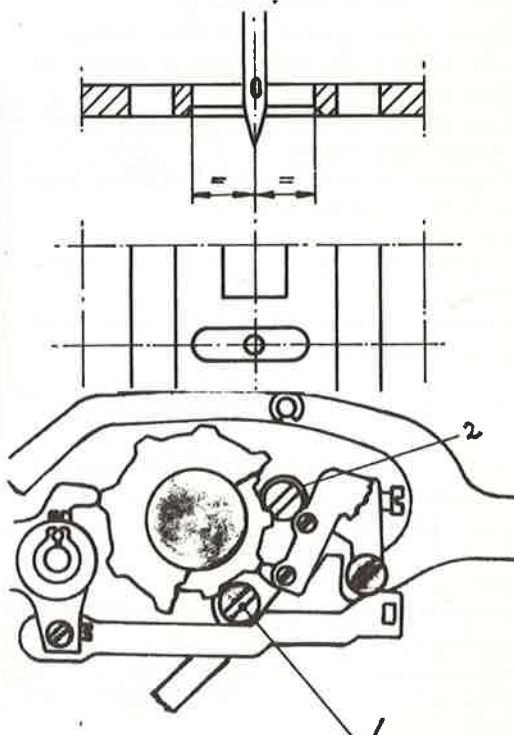

Setting zig zag width.

Set pattern selector on zig zag and width on 4.
 Drop the feed and place a business card under presser foot.
 Lower needle into extreme left and right positions. Measure marks.
 Distance should be same as dimension A, figure 172.
 Loosen screw(1), figure 171, turn counterclockwise to increase width.
 Turn clockwise to decrease width.

Figure 171

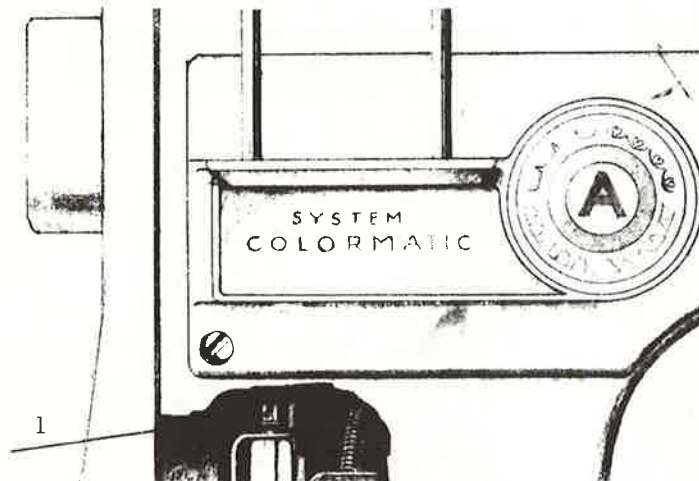

Zig zag adjustment, 21-51

Figure 173

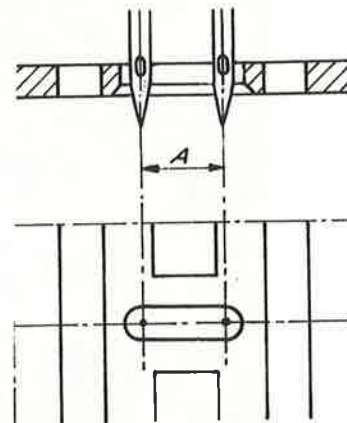

Figure 172

Set zig zag lever on left position.
 Place cam pattern on 5.
 Open rear plate and turn balance wheel until cam follower(1) contacts a lobe on the cam.

Loosen screw(2) and adjust follower to pivotal point.

Tighten screw(2) and turn zig zag dial to 0, and back to 4.

Extreme caution should be exercised when working on or near camstack.

Camstack material is fragile and can be easily broken.

Timing zig zag motion.

If machine develops a loud clatter or needle bar jumps violently to right on upward zig zag stroke, worm gear and camstack spur must be adjusted.

Remove rear inspection plate and camstack.

Loosen set screws(2), figure 174, next page, and move worm gear to-

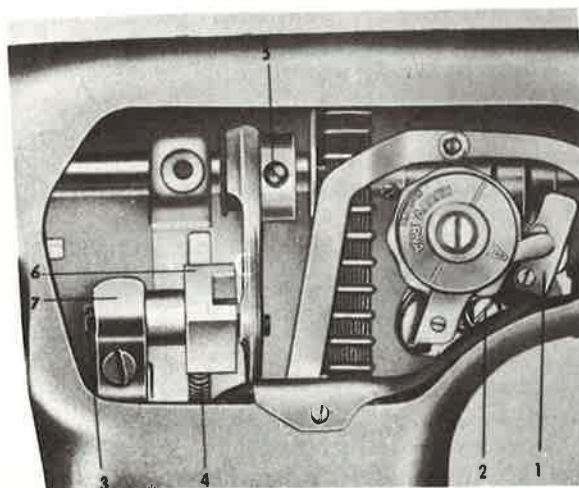

ward cam spur gear(3), until gears are properly meshed.

Loosen set screws on collar(4), and move snugly against worm gear.

Tighten set screws on worm gear and turn balance wheel several times.

If binding occurs, gears are too close together.

Loosen screws, move back until mesh is smooth.

Tighten screws.

Tighten collar and test sew,

Figure 174

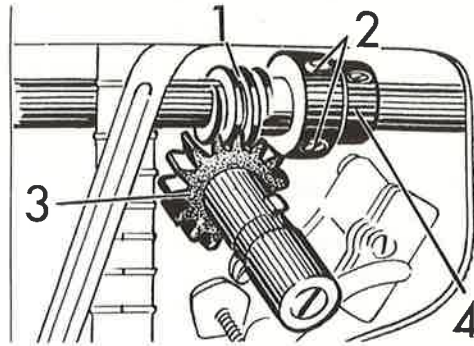

Timing zig zag movement, new style.

Open rear inspection plate.

Place pattern selector on zig zag and stitch width indicator on 2.

Loosen worm gear screws and turn pattern cam clockwise until follower contacts cam.

Hold worm gear and cam, turn balance wheel until needle reaches lowest point.

Tighten set screws and test sew, adjust further if necessary.

To check path of needle on zig zag, set dial on 4 and observe descent.

Needle should stop swinging and start downward into cloth, about 1/4" above needle plate.

As it rises, the needle swing should start about 3/8" above the plate.

Figure 175

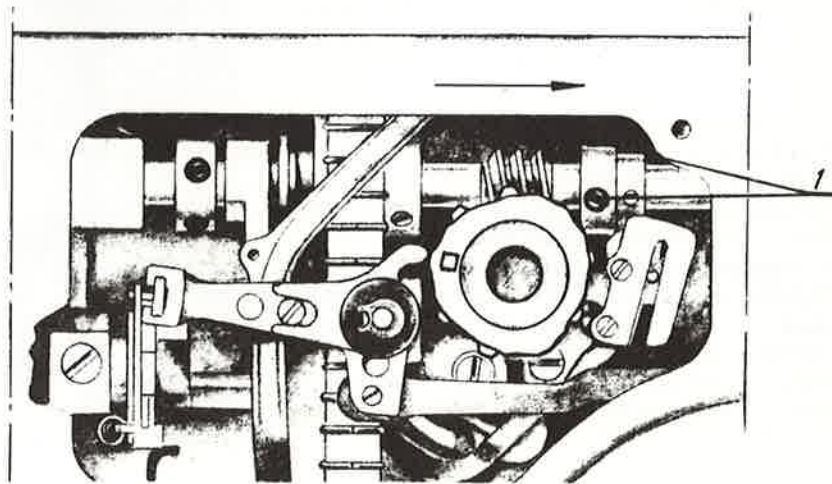
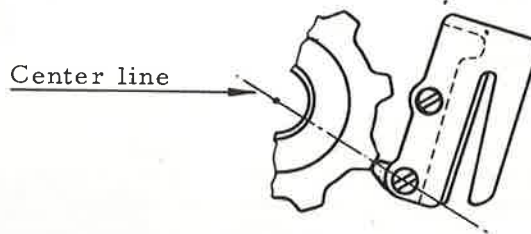

Adjusting end play in main shaft

An indication of main shaft end play, is excessive noise or vibration especially when using automatic patterns.

Loosen set screw and remove wheel.
Loosen set screws(1) on collar, and slide collar against front main bearing until snug.

Leave a small crack for oiling.
Tighten set screws.
Replace wheel and test sew.

Figure 176

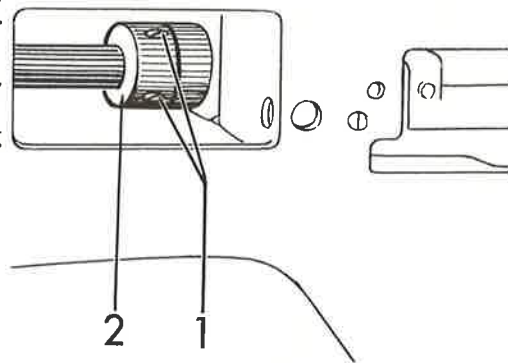

Gear reduction box.

The gear box serves a dual purpose. In addition to gearing down to the slow speed, it contains the bobbin winder.

When bobbin is placed on spindle(A), machine is taken out of gear.

Remove bobbin, machine's in gear.
To remove or adjust, the shield has to be removed.

Loosen three screws(1 & 2, fig.178 lower right).

Remove button on model 20 and 21.
Loosen screws(3) and remove gear box, pull it toward you.

If machine fails to change gears, a spring may be broken.

Check spring on gear(f), figure 177, and replace if broken.

Figure 177

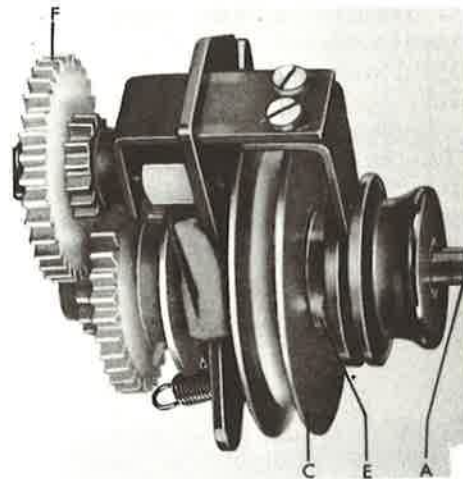

Changing drive belt.

To change drive belt, loosen the set screw holding balance wheel, remove.

Remove belt from pulley(D, fig 177) and replace with a new one.

Belt is "V" type and is available.

Figure 178

Changing motor belt.

To change motor belt, loosen gear box and move toward the motor.

Remove worn belt and replace.

Use the "V" type if possible.

Place belt over pulley and move the gear box until belt is taut.

Tighten set screw(1) and position as needed.

Tighten screw(c) and replace cover.
Figure 180 illustrates later system.
Button is attached to gear box.

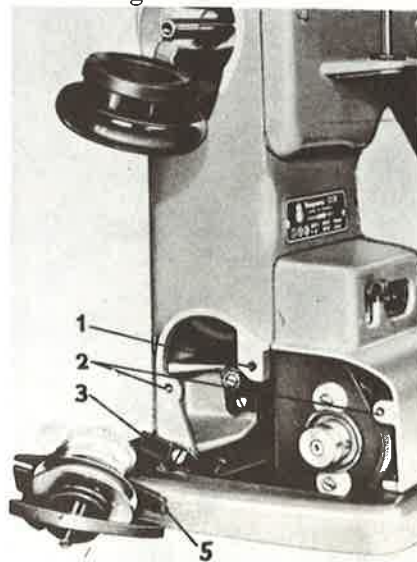

Gear box and motor assembly, new style.

Figure 179

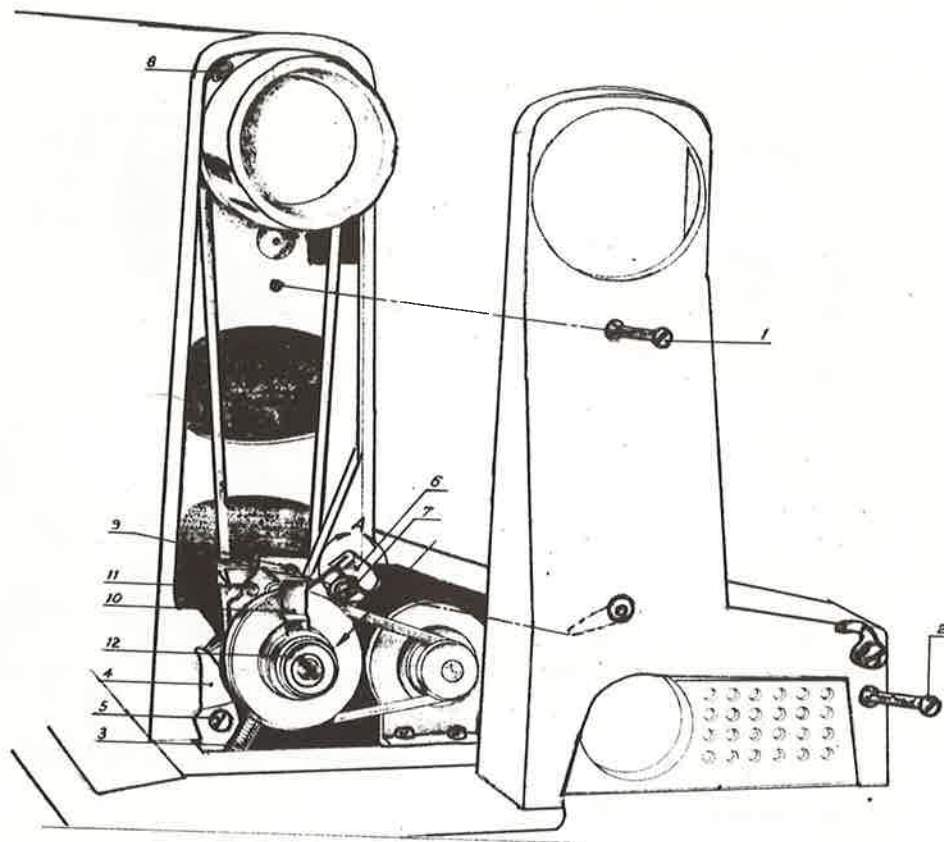

- To adjust for gear noise or malfunction, remove the cover plate.
 Loosen screws(1 and 2, figure 179).
 Turn eccentric screw(11), clockwise to decrease tension between shafts (gear mesh), or counterclockwise to increase it.
 Keep machine running during this adjustment.
 To change drive belt, remove cover plate.
 Loosen screw(5), disconnect spring(3) from guide plate(4) and remove the motor belt.
 Remove gear box.
 Remove balance wheel and drive belt.
 Replace belt with "V" type, see text page 136.
 Replace gear box.
 To replace balance wheel, place on shaft and push on as far as possible.
 Tighten screw(8).
 After gear box is in place, tension it in place with drive and motor belt.
 When both belts are taut, tighten screw(5).
 To replace motor belt alone, loosen screw(5) and move gear box toward motor.
 Put on new belt and tension as needed.
 When both belts are taut, tighten screw and replace cover.

Partial cut-away and description of the Viking 21E.

Figure 180

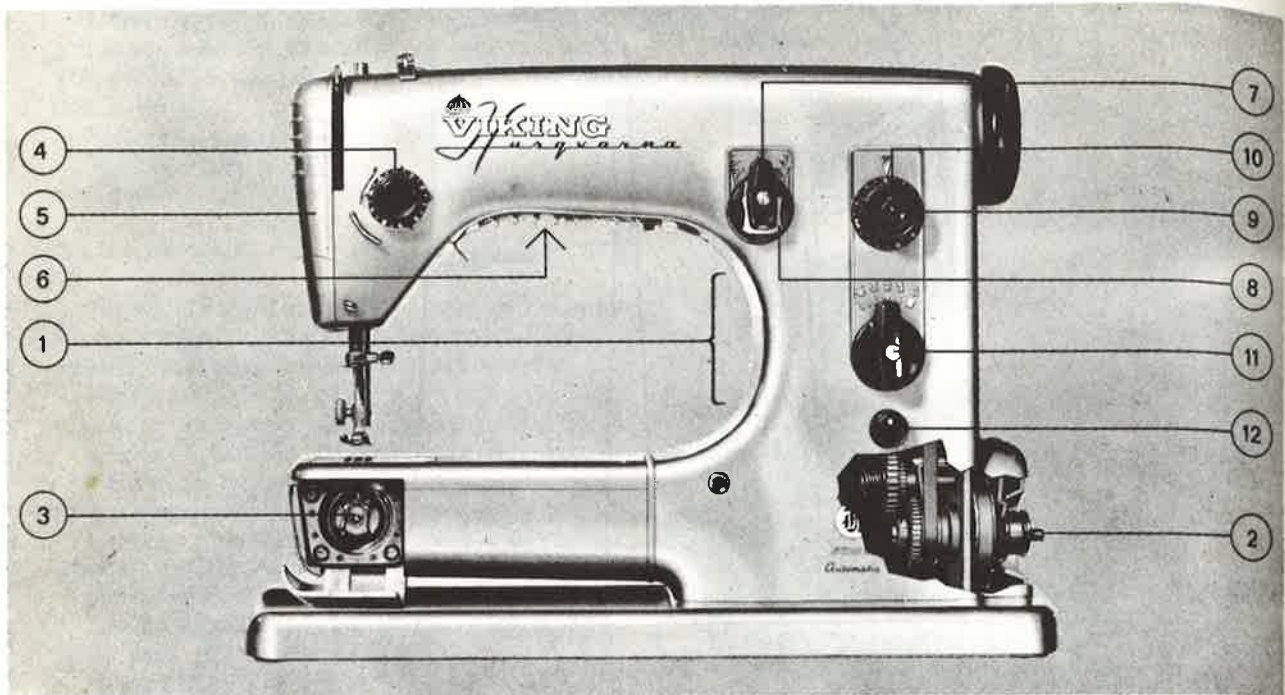

Viking Automatic #21E



1. The head and the free arm are cast in one and the same piece—a guarantee of superior strength and lasting precision.
2. Low-speed gear—just pull out the button, and the machine sews with 1/5th of its normal speed with the same pressure on the pedal—while the motor power increases accordingly.
3. 100% jam-proof shuttle. Needs no oiling, does not soil the thread.
4. Thread tension is clearly graduated from 0 to 9.

5. Pressure on the presser foot releases with a flick of the finger. You can darn and mend with the ordinary presser foot.
6. Built-in sewing light gives a glare-free and pleasant light over the working area.
7. Regulation knob for the zig-zag seam's starting position (right, left or center).
8. Pattern selector.
9. Press the button and this machine sews in reverse, release and the machine sews forward again. The

- button can also be locked in reverse.
10. The stitch length regulator has a micro-setting for the shortest stitches.
11. The control for seam width is graduated from 0 to 4 and can be set for any width between these figures.
12. The feed dog can be lowered with this control; for embroidering and darning.
13. The motor is equipped with a radio and TV disturbance suppressor.

The Riccar Automatic

The model RZ304B is a typical Japanese-made automatic. Simple to operate, and built to sew numerous designs automatically. Riccar makes several machines of similiar design, but the model RZ304B will be covered in depth.

Owners of other brand name machines of Japanese manufacture may refer to this chapter for service. Many of the service and repair procedures are the same.

Like many of their contemporaries, Riccar utilizes the class 15 mechanism. Some models are straight class 15, others utilize the transverse hook arrangement.

Figure 182

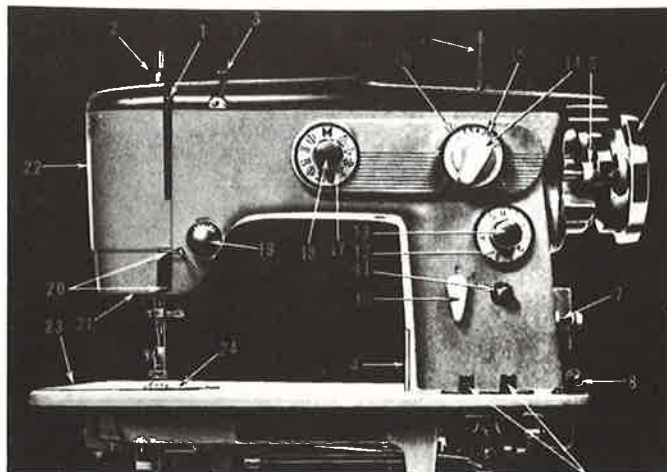

- | | |
|-------------------------------------|------------------------|
| 1. Thread Take Up Lever | 28. Presser Foot |
| 2. Patch-O-Matic Darnner | 29. Open Race |
| 3. Arm Thread Guide | 30. Presser Bar Lifter |
| 4. Spool Pin | 31. Cam Door |
| 5. Hand Wheel | |
| 6. Bobbin Winder | |
| 7. Built-in-Light Switch | |
| 8. Bobbin Winding Thread Guide | |
| 9. Drop Feed Push Button | |
| 10. Button Holer Device | |
| 11. Reverse Sewing Push Button | |
| 12. Stitch Length Regulating Dial | |
| 13. Stitch Length Regulating Knob | |
| 14. Zigzag Width Regulating Knob | |
| 15. Zigzag Width Regulating Dial | |
| 16. Needle Position Regulating Knob | |
| 17. Pattern Selecting Dial | |
| 18. Pattern Selecting Knob | |
| 19. Upper Thread Tension | |
| 20. Thread Guide | |
| 21. Built-in-Light | |
| 22. Face Plate | |
| 23. Slide Plate | |
| 24. Needle Plate | |
| 25. Needle Bar | |
| 26. Needle | |
| 27. Presser Bar | |

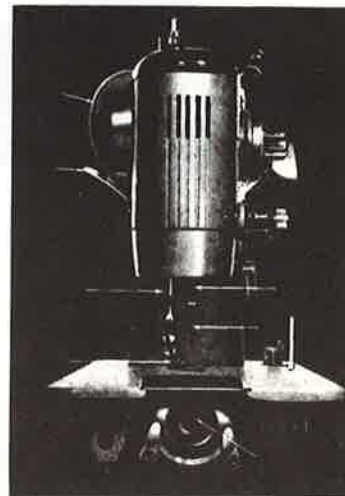

Upper tension assembly

The tension assembly as pictured in figure 182 is unitized, and entire assembly may be removed at the same time.

The tension dial is calibrated, and should be used to adjust the tension unless there is a malfunction elsewhere.

A setting of 3 to 5 is necessary for regular sewing, then a tighter or looser stitch setting can be made when the situation warrants it.

Most common problem of a tension assembly, is the thread cut disc. If a tension disc is thread cut, replace it.

Proper check spring adjustment is necessary, especially in zig zag sewing. The spring is properly adjusted when it releases the thread as the eye of the needle enters material, on the downward stroke.

If check spring is out of adjustment, proceed as follows:

Open face assembly door (figure 182a).

Use the tension screwdriver and loosen set screw (1). Remove tension assembly.

Loosen both screws on tension assembly block (figure 182b), and pull the tension stud outward.

If the check spring is broken or bent, replace it.

When adjustment is necessary, replace the spring over end of tension stud, with small finger of spring fitted into one of the slots on stud.

Replace tension stud in block and snug-tighten the two screws.

Flick check spring with your finger. If spring appears weak, loosen the two screws and turn tension stud clockwise, slightly. Tighten screws.

If spring seems too tight, loosen the screws and turn tension stud counterclockwise. Tighten both set screws.

Replace tension components and test sew. Reset tension to proper setting.

Check spring adjustment is largely "Feel". What is proper amount of check spring on one machine, may be too little on another.

Figure 182



Figure 182b

Figure 182a

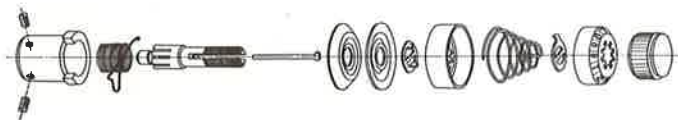
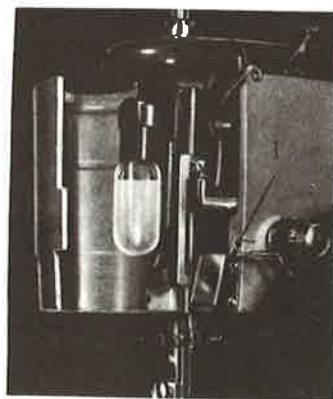

Lower sewing mechanism

Figure 183

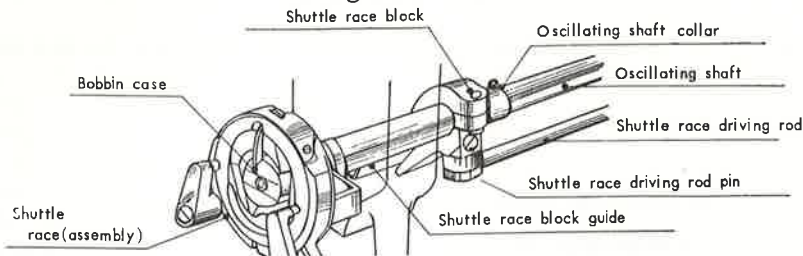

The shuttle mechanism on a zig zag machine (class 15), is basically the same as a class 15 straight stitch, except it moves back and forth in rhythm with the needle bar when the zig zag control knob is turned.

Figure 183 illustrates the lower sewing mechanism and components.

To adjust the lower tension, remove bobbin case from shuttle spindle.

Check bobbin case for proper threading (figure 183a).

If the bobbin case is properly threaded and machine still sews badly, and the upper tension is properly set, adjust bobbin case tension screw.

If lower thread is pulling through cloth, use the tension screwdriver to adjust screw (figure 183b), clockwise to tighten lower tension.

When upper thread is pulling down through cloth, turn screw counter-clockwise to loosen lower tension.

If either adjustment fails to correct the situation, remove screw entirely and check the tension spring (c & d, figure 183c).

If tension spring is bent, broken, or thread cut, replace it.

Bobbin case body should also be checked for thread cuts. If it's damaged, replace it. Emery cloth can dress it up temporarily, but replacement would be best.

If bobbin case doesn't latch, when placed on shuttle spindle, check the groove on the spindle for lint or pieces of thread.

When shuttle is clean, check latch assembly (A' & B, figure 183c), and the small spring illustrated next to bobbin case.

The latch must work smoothly in the slotted raceway. If it doesn't, replace the entire bobbin case.

Remove shuttle and check race area for lint or broken threads. After cleaning the area, put a few drops of oil on the shuttle.

Replace all components in proper order.

Inspect the shuttle. If the point is broken, or marred by numerous needle strikes, replace the shuttle.

Figure 183a

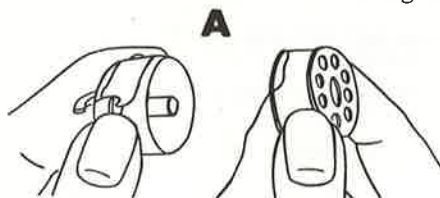

Figure 183b

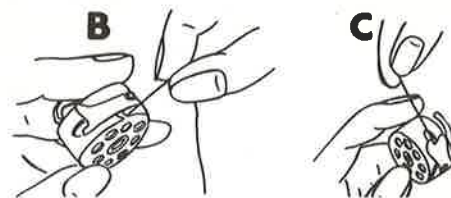
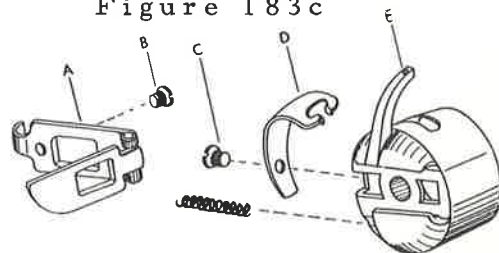
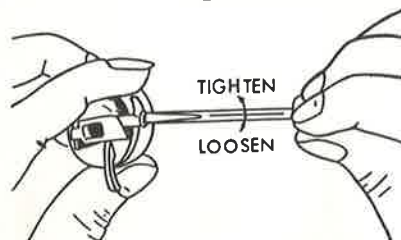

Figure 183c



The zig zag mechanism

The RZ304 zig zag mechanism is similiar to text covering the manual zig zag machine on pages 85 and 86.

Figure 184

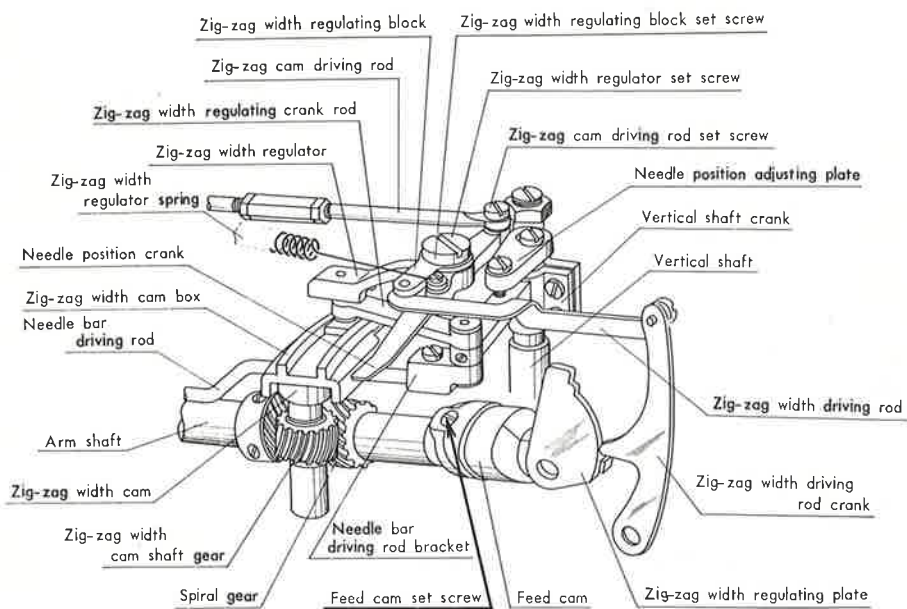

Needle bar and connecting components

Figure 184a

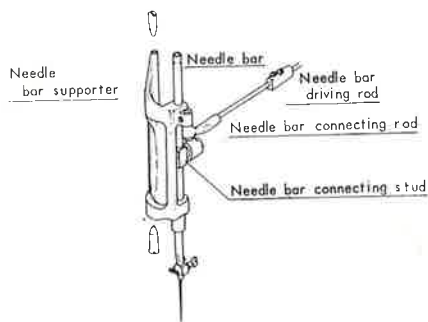

The Automatic Mechanism

Figure 185 illustrates the basic components of the automatic assembly. The indicator plate assembly(185a) fits over the extended shafts of the assembly on the upper arm of the machine. The nomenclature on each part is self explanatory. Service and repair principals will be covered on the next several pages.

Figure 185b illustrates the zig zag width control and the needle position dial. L, M and R stand for Left, middle and right respectively. Do not confuse the M on the Cam selector dial with the M on the needle position dial. The "M" on the Cam Selector Dial indicates the machine can make manual zig zag stitches at that point, otherwise, the machine will sew the stitch the cam selector indicates.

Figure 185

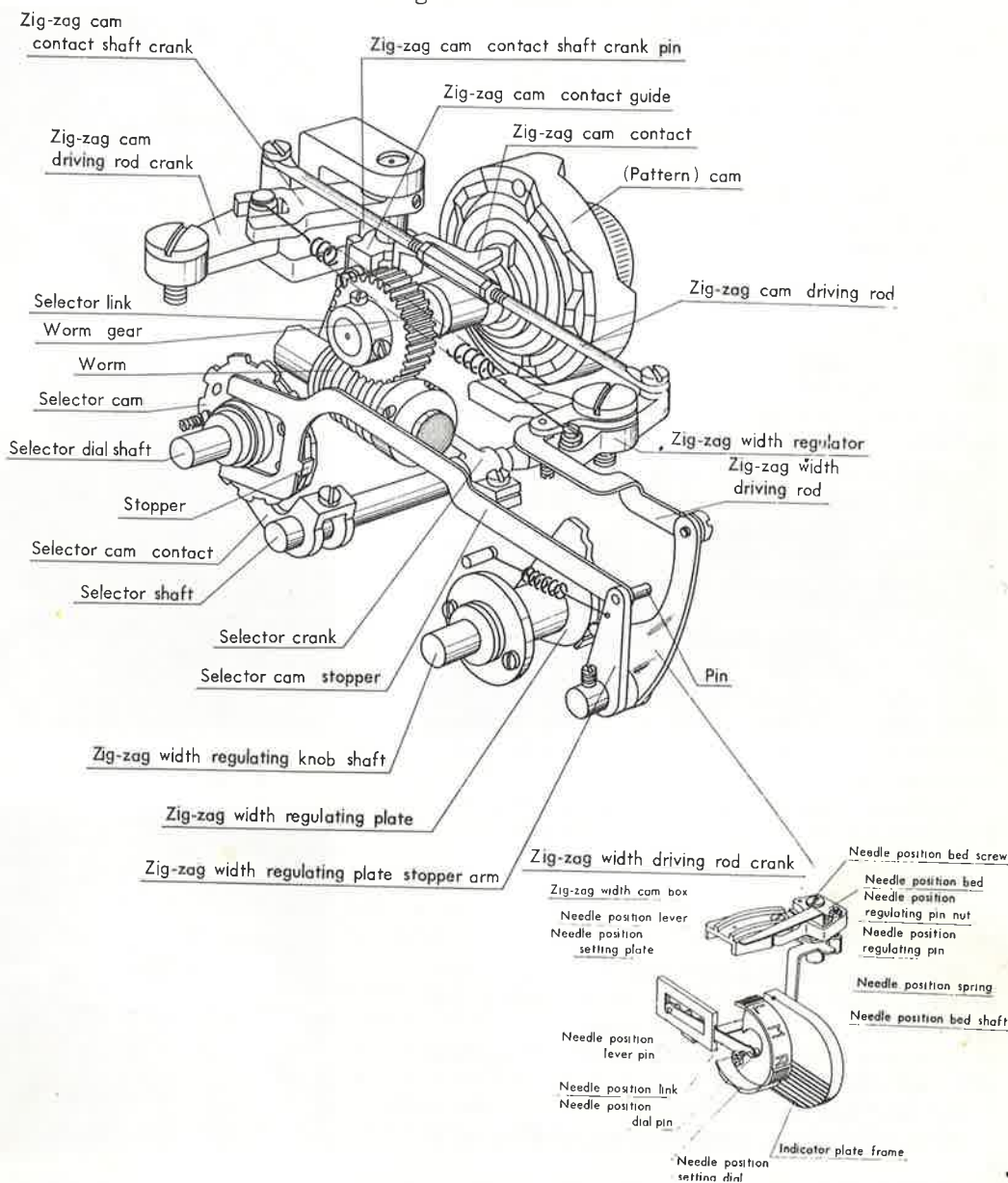

Gear Adjustment: Zig Zag

To adjust the mesh of the main shaft, and the spiral gear on the zig zag width cam shaft, loosen set screw located under control panel. (figure 186).

Insert screwdriver in driver hole.

Turn zig zag width cam shaft supporter(it's eccentric), slightly to the right, or left, as needed to correct.

Adjustment: Needle to needle hole

To adjust, replace zig zag plate with straight sew needle plate.

Remove top cover from machine.

Set zig zag control dial on setting 1.

Loosen set screw (a), figure 187, on needle bar driving rod bracket.

Adjust the rod(B), until needle enters needle plate at proper place.

Tighten all screws, and replace top. Test sew.

Adjustment: Zig Zag width regulator

Place needle position lever(figure 187a) in left position.

Turn balance wheel, remove top cover, and observe. Cam block(C), figure 187 should be in extreme left position.

When needle enters needle plate, stop turning the balance wheel.

Move zig zag control dial back and forth and if needle moves, adjustment is required.

Loosen needle position regulating pin nut(D), figure 187.

Pin(E), is eccentric. Turn slightly, then turn balance wheel by hand. When needle doesn't move back and forth, adjustment is correct.

Tighten nut(D), and double check the adjustment with straight needle plate.

Replace top cover and test sew.

Adjusting zig zag swing

When needle doesn't enter needle hole at same place, on left or right swing, refer to figure 187 for adjustment.

Remove top cover and loosen set screw (F), on spiral gear.

Set zig zag control on 5.

Observe which direction the needle bar

Figure 186

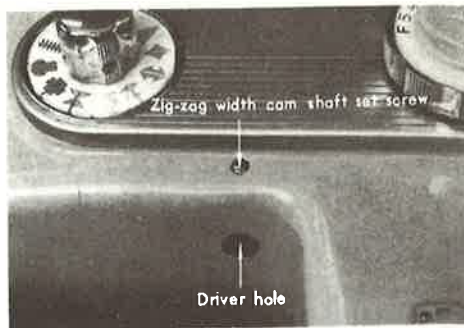

Figure 187

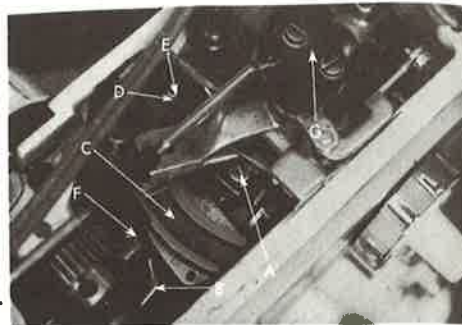

Figure 187a

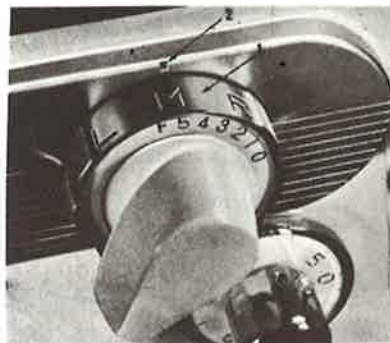
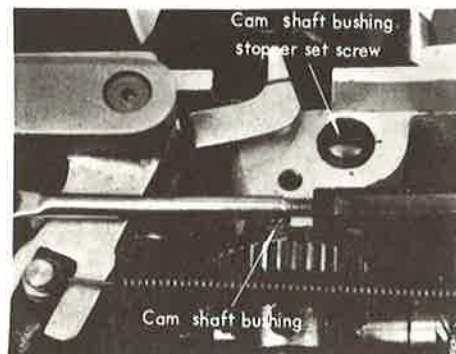

Figure 188



must be moved. Move the gear, either right or left, as needed to adjust.

Tighten set screw. Use extreme caution, don't allow the gear to slip.

Adjustment when machine zig zags on straight setting.

Set zig zag width control dial on "0" setting.

Remove top cover.

Loosen set screw (figure 187), located on needle position adjusting plate (G), page 146.

Turn balance wheel.

Adjust needle position plate (G), until needle rises and falls in same place.

Tighten set screw and test. Place a business card under presser foot and turn balance wheel by hand. When the needle rises and falls in same hole, without enlarging it, the adjustment is correct.

Adjustment of cam shaft worm gear.

If cam shaft gear is out of mesh, adjust as follows:

Remove top cover.

Loosen set screw on cam shaft bushing (figure 188).

Turn cam shaft bushing until gears mesh properly.

Tighten set screw.

Replace top cover plate, and test sew.

Figure 188a



Figure 189



Adjustment of cam contact finger.

Put a cam in machine (see figure 188a), and turn balance wheel until pin on cam shaft is straight up.

Set zig zag width control dial on 0.

Check the regulator, it must position needle stop.

Move cam driving rod until extreme point of cam control is slightly detached.

If cam contact is between two cam tracks, adjust as follows:

Set zig zag regulator dial on setting "F".

Turn selector dial until cam contact is at its highest point.

Loosen set screw on selector crank (figure 189, page 148), move the cam contact up, or down. Cam contact should descend on the middle of inner cam track, or M position (figure 189a). If adjusted properly, tighten selector arm securely.

Check the other cam tracks and watch selector stop. It should operate the zig zag width regulating dial, and pattern selector dial, in turn.

Adjusting the pattern selector

If machine doesn't sew pattern indicated on pattern selector dial(5, figure 189a), the dial may be out of place.

Loosen pattern dial screws, and turn dial until pattern corresponds with pattern being sewn. Tighten set screws.

The zig zag cam control MUST move freely on zig zag cam shaft.

Figure 189a

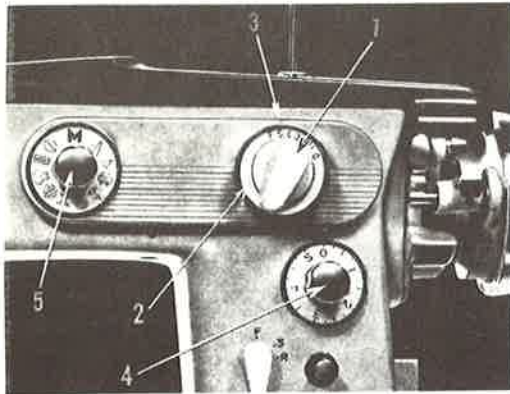

Buttonholer assembly

When adjusting the buttonholer assembly put needle bar in left position, and pattern selector dial on "M".

Remove top cover, and hand wheel cover, if one is present.

If machine is sewing a denser stitch in forward, than reverse, loosen feed regulator bushing, set screw(figure 190).

Turn feed regulator bushing counter-clockwise, as needed. Tighten screw.

If machine is sewing a denser stitch in reverse, repeat procedure, but turn feed regulator bushing, clockwise, as needed.

NOTE: Unless the special tool furnished by Riccar is used, balance wheel will have to be removed for adjustment.

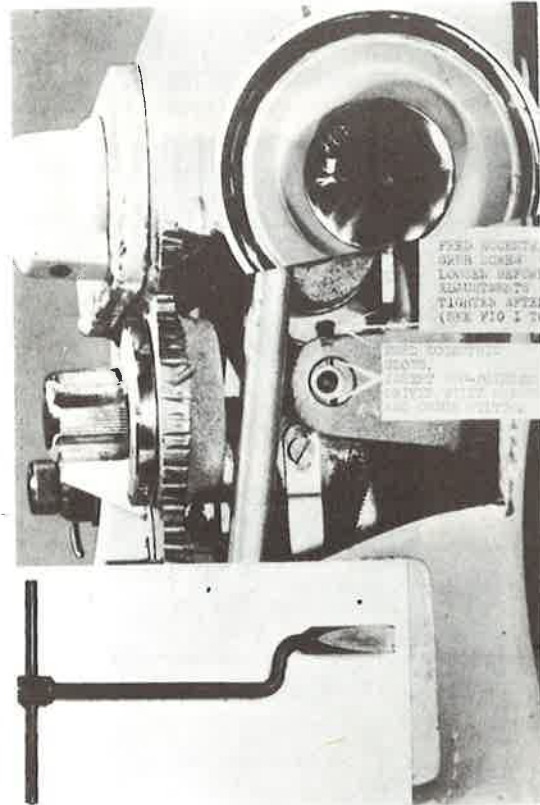

Figure 190

Adjusting buttonholer bar tack.

To adjust the bar tack, set zig zag dial on 0, and buttonholer knob on S.

Turn balance wheel until zig zag width cam block(A), arrives at extreme right position.

Loosen set screws(B, figure 191), on needle position crank and turn until needle is at center, at maximum zig zag width adjustment, and extreme right.

Hold needle position crank(C, figure 191), at the point where bar tacking crank, (D), touches zig zag width cam block(A).

Figure 191



Timing

Figure 192

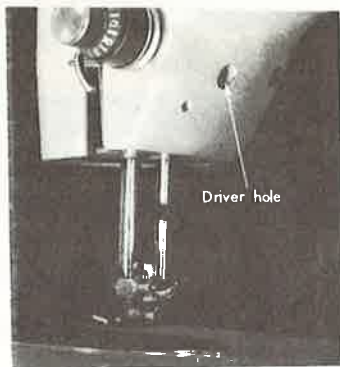

Figure 192a

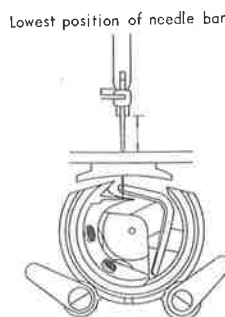
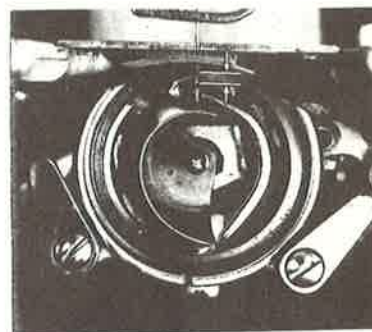

Figure 192b



If the machine skips stitches, remove shuttle race cover, and bobbin case. Tilt machine head back, and set zig zag regulator knob on setting 0. Thread machine, and turning balance wheel slowly, observe the needle travel, and its relation to the shuttle point when needle starts its upward travel.

Timing is incorrect if shuttle point doesn't pick up the upper thread.

To adjust, loosen set screw on needle bar, through driver hole (figure 192, and move needle bar until needle is in proper position.

Figure 192b shows proper position of needle in relation to shuttle hook at lowest point of needle bar travel.

Tighten set screw, replace shuttle components, and test sew.

Figure 192a, shows position of needle bar at lowest position. Measurement between arrows should be approximately $25/64$ ths of an inch.

The proper distance between eye of needle and point of hook, at position shown in figure 192b, is $3/32$ ".

Before timing a sewing machine, always start with a new needle, and be sure needle is properly inserted.

To adjust clearance between needle and point of hook, loosen shuttle race block screw (figure 192c).

Proper clearance is $.004$ ". This is quite close, about the thickness of a sheet of paper, doubled.

Move entire race assembly to correct. Remove needle plate.

Check needle position. Race assembly must not turn while this adjustment is being made. The needle must pass through the center of slot.

Tighten set screw on race block, and test sew.

Figure 192c

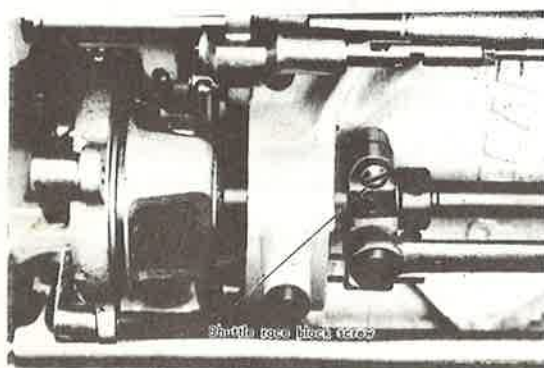

Relation of shuttle race upper spring and needle position

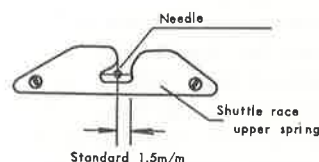

Adjusting the oscillating shaft.

When there is end-play in the oscillating shaft, loosen set screws on the shaft collar and adjust. (See figure 193).

Move collar slightly to the left, and the shaft to the right.

Tighten set screws snugly.

Turn balance wheel by hand. If machine binds, collar is too tight.

Loosen set screws and back collar off slightly. Tighten set screws.

Figure 193

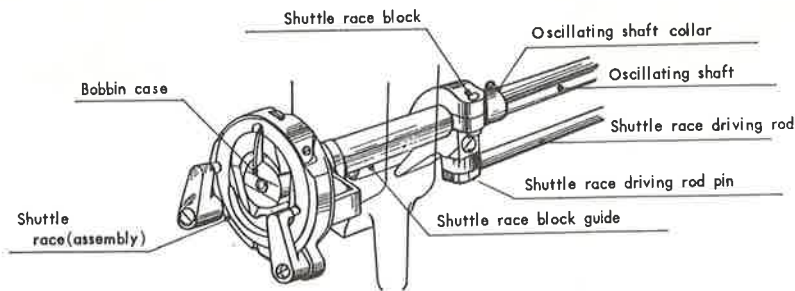

Adjusting the feed dog.

The proper height of the feed dog is $1/32$ " above needle plate, at its high point.

If adjustment is required, loosen feed lifting rock shaft clamping screw (figure 193a), and adjust as needed. (Figure 193a on page 151).

If feed dog is too low, raise it to proper height. If it's too high, lower to proper height, at high point of feed dog rise.

Tighten set screw and test.

Although this adjustment should solve the feeding problem, the presser bar unit might also need adjusting, and don't overlook the drop feed. It may be in "DOWN" position.

If problem is in presser bar assembly, open face plate door, and raise the presser bar lifter (figure 193b, page 151).

There should be about $1/4$ " clearance between the needle plate and lower part of presser foot, when the lifter is in "UP" position.

Loosen set screw on presser bar guide bracket.

Adjust to proper setting and tighten set screw.

When making this adjustment, hold presser bar firmly in place. If the presser bar slips, needle will strike presser foot, especially on wide zig zag stitching.

If pressure seems to be insufficient to feed material, screw patchomatic down as far as it will go. If the foot still lacks enough pressure, remove the darner assembly, and the presser spring.

Stretch the spring, replace spring and darner assembly, and test.

NOTE: If the spring is broken, replace it.

When your machine is not equipped with a darner, turn adjustment nut.

Figure 193a

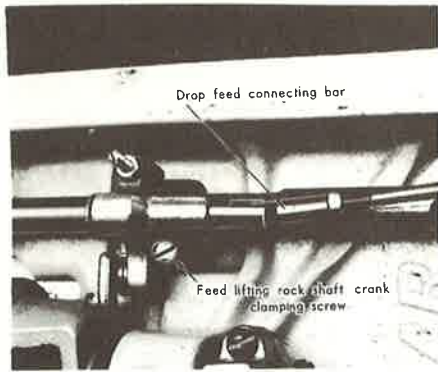
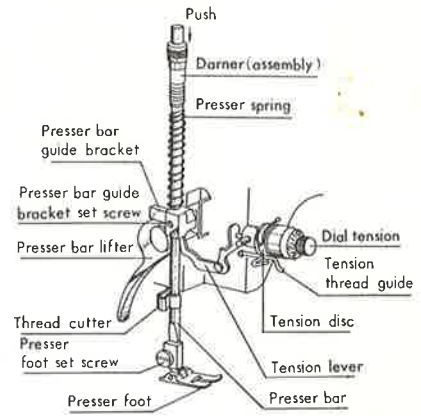

Figure 193b



Timing the feed system.

When the feed system is properly timed, the feed dog starts its motion, when the needle is at its highest point.

To adjust, place stitch length control lever on longest stitch. Loosen feed cam set screw.

Move cam until angle changes. Tighten set screw and test.

If further adjustment is needed, repeat the procedure.

To advance the feeding, turn cam clockwise.

To retard the feeding, turn cam counterclockwise.

Most machines have a timing mark on the feed cam. Set it on mark cut on the arm shaft, and feed timing should be accurate.

Figure 194

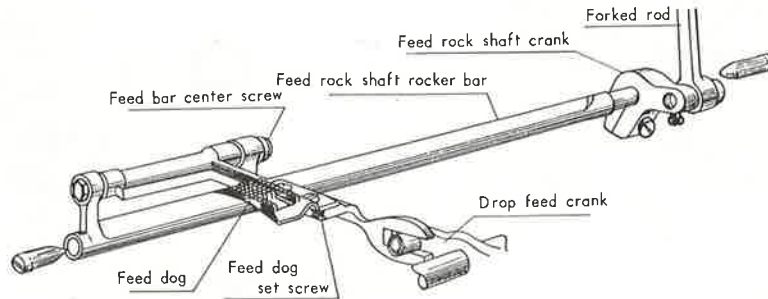
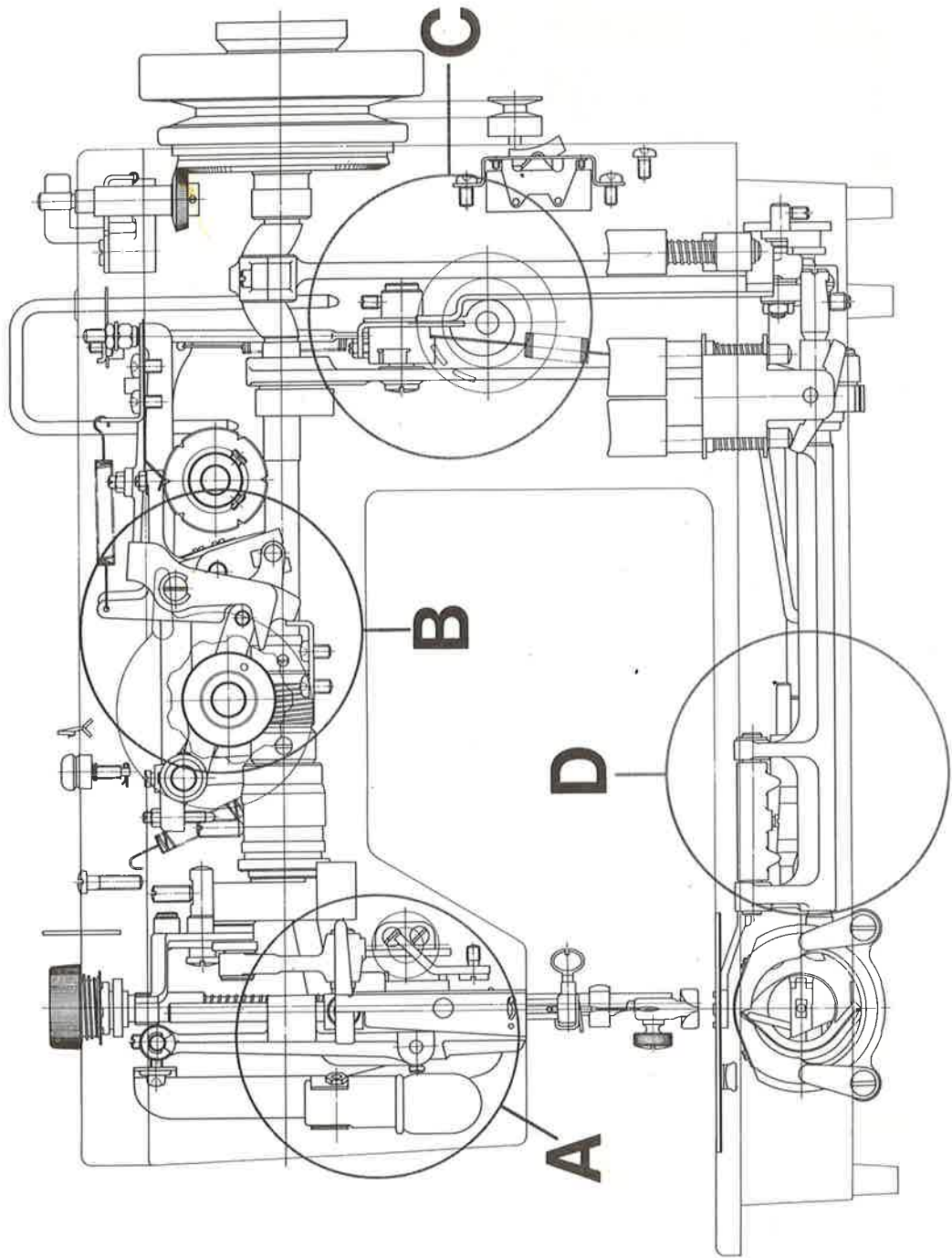
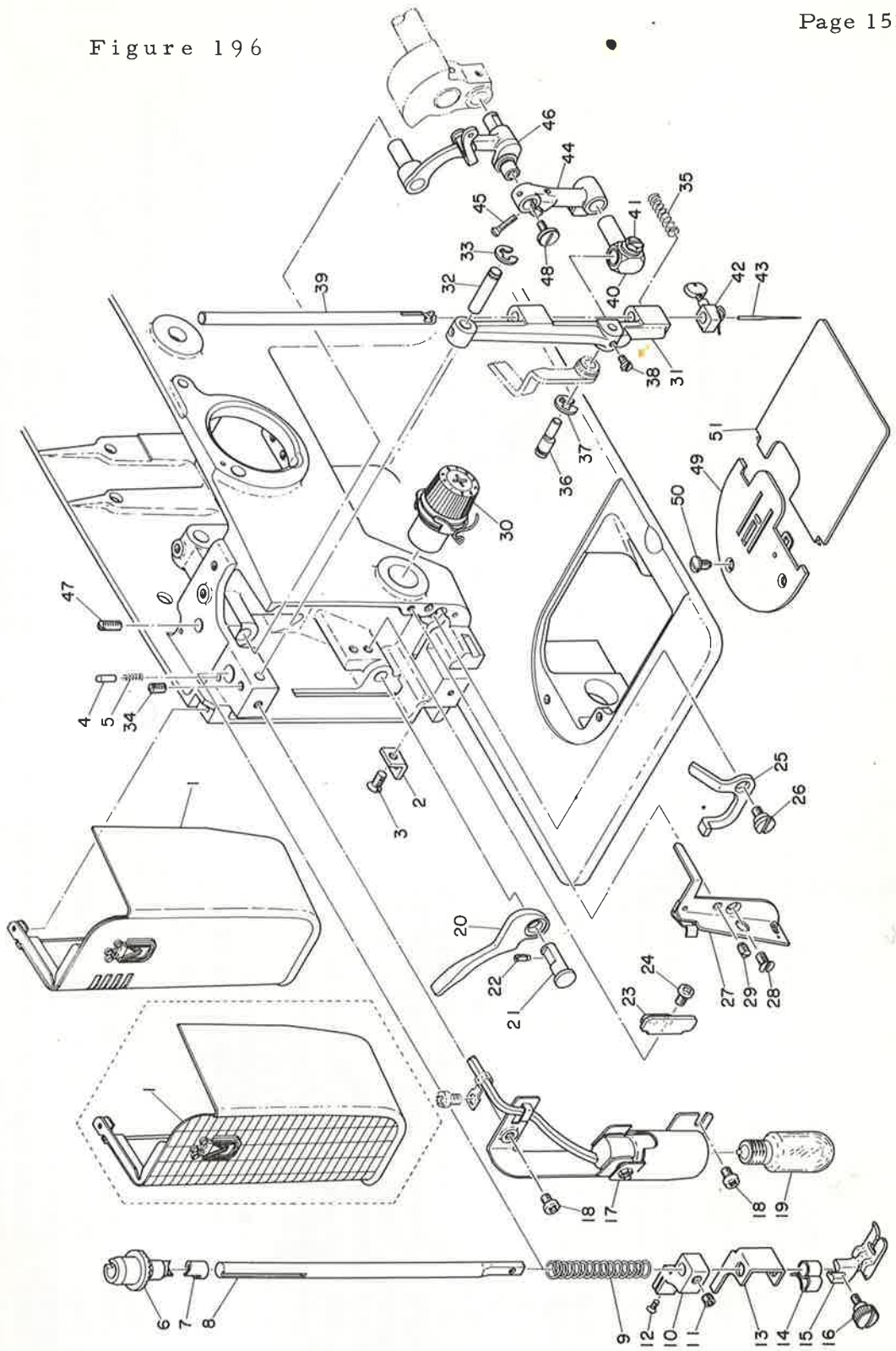

Figure 195

MECHANICAL DRAWING OF RZ-777



BLOCK-A



PARTS LIST

1.	Z-5510	Face plate (compl.) (RZ-777)	26.	Z-6125	Tension lever step screw
(1)		Face plate (compl.) (RICCAR-777)	27.	Z-5540	Arm thread guide (compl.)
2.	Z-5517	Face plate hinge	28.	Z-5518	Arm thread guide set screw
3.	L-6227	Face plate hinge set screw	29.	Z-6048	Dial tension set screw
			30.	L-4060	Dial tension (compl.)
4.	L-4082	Pressure regulator dial stopper pin	31.	Z-6044	Needle bar supporter
5.	L-4083	Pressure regulator dial stopper pin spring	32.	Z-6046	Needle bar supporter pin
6.	Z-5546	Pressure regulator	33.	Z-6047	Needle bar supporter pin set ring
7.	L-4084	Presser spring supporter	34.	Z-6048	Needle bar supporter pin set screw
8.	L-4086	Presser bar	35.	Z-6045	Needle bar supporter spring
9.	Z-5547	Presser spring	36.	Z-5853	Needle bar driving rod pin (eccentric)
10.	L-4091	Presser bar bracket	37.	Z-6047	Needle bar driving rod pin set ring
11.	H-1063	Presser bar bracket set screw	38.	Z-1363	Needle bar driving rod pin set screw
12.	L-1073	Presser bar bracket adjusting screw	39.	Z-6043	Needle bar
13.	Z-5545	Tension lever lifter	40.	Z-5930	Needle bar bracket (compl.)
14.	H-1065	Thread cutter	41.	Z-5949	Needle bar bracket set screw
15.	Z-1050	Presser foot (compl.)	42.	Z-6080	Needle clamp (compl.)
16.	Z-2084	Presser foot thumb screw	43.	H-1413	Needle
			44.	Z-5551	Needle bar crank rod
17.	Z-5880	Lamp holder (compl.)	45.	H-1077	Needle bar crank rod set screw
18.	L-4036	Lamp holder set screw (2 pcs.)	46.	Z-5570	Thread take-up lever (compl.)
19.	Z-5895	Lamp	47.	Z-1187	Thread take-up lever set screw
20.	Z-2083	Presser bar lifter	48.	Z-1185	Arm shaft balance pin left handed screw
21.	H-1068	Presser bar lifter pin	49.	Z-5561	Needle plate
22.	H-1069	Presser bar lifter pin set screw	50.	H-1394	Needle plate set screw (2 pcs.)
23.	Z-5552	Needle bar crank guide	51.	Z-5562	Hinged plate
24.	L-4036	Needle bar crank guide set screw (2 pcs.)			
25.	Z-5544	Tension lever			

NOTE: Parts in bracket must be ordered together with the parts which they are assembled with.

NOTE: Parts in bracket must be ordered together with the parts which they are assembled with.

BLOCK-B

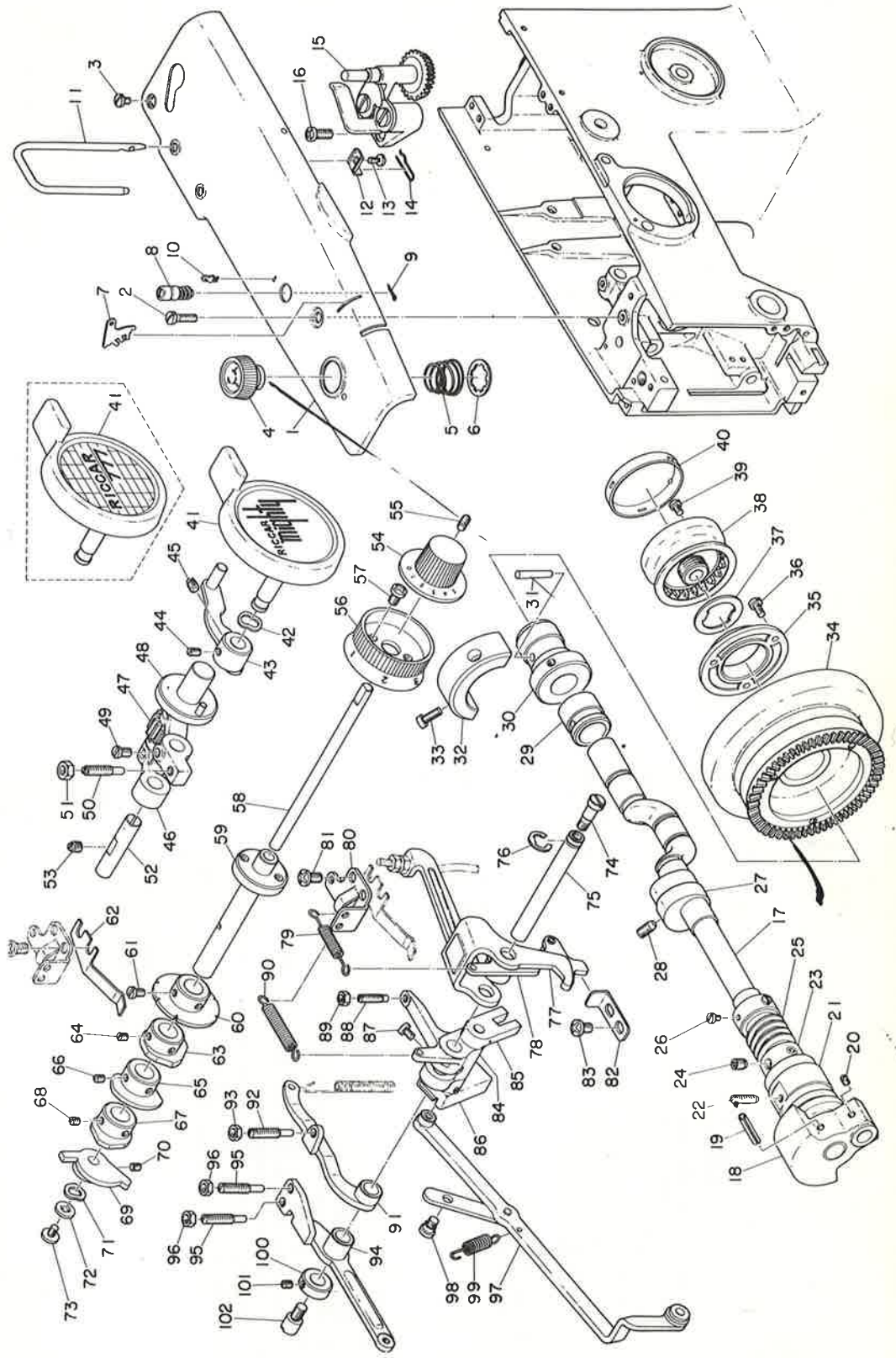

PARTS LIST

1.	Z-5521	Arm cover							
2.	Z-2307	Arm cover set screw (2)							Zigzag width regulating cam set screw (2 pcs.)
3.	Z-6041	Arm cover set screw (1)							Zigzag width regulating dial shaft spring washer
4.	Z-5533	Pressure regulator dial							Zigzag width regulating dial shaft washer
5.	Z-5535	Pressure regulator dial spring							Zigzag width regulating dial shaft fastening screw
6.	Z-5536	Pressure regulator dial spring set washer							Cam contact shaft fastening screw (2)
7.	Z-5531	Arm cover thread guide (1)							Cam contact shaft
8.	Z-5950	Thread guide (compl.)							Cam contact shaft set ring
9.	L-6087	Thread guide adjusting screw set pin							Feed cam contact
10.	Z-5532	Arm cover thread guide (2)							Zigzag width cam contact
11.	Z-5537	Spool pin							Zigzag width cam contact spring
12.	Z-5528	Spool pin adjusting plate							Spring holder
13.	L-1104	Spool pin adjusting plate set screw							Spring holder set screw (2 pcs.)
14.	Z-5538	Spool pin spring							Cam contact stopper
15.	Z-5870	Bobbin winder (compl.)							Cam contact stopper set screw (2 pcs.)
16.	L-4124	Bobbin winder set screw (2 pcs.)							(2 pcs.)
17.	Z-5581	Arm shaft (assembled)							Needle position conductor (compl.)
18.	Z-2101	Arm shaft balance							Zigzag width connecting fork
19.	L-2044	Arm shaft balance set pin							Zigzag width controller
20.	H-1069	Arm shaft balance set screw							Zigzag width controller slide block stopper set screw
21.	Z-5582	Arm shaft bushing (1)							Needle position conductor adjusting screw
22.	Z-5592	Arm shaft bushing (1) set screw							Needle position conductor adjusting screw nut
23.	Z-6156	Arm shaft collar							Needle position conductor spring
24.	Z-6571	Arm shaft collar set screw (2 pcs.)							Buttonholer feed lever
25.	Z-5591	Worm							Buttonholer feed lever adjusting screw nut
26.	H-1174	Worm set screw (2 pcs.)							Buttonholer feed lever adjusting screw
27.	H-1396	Feed cam							(2 pcs.)
28.	H-1254	Feed cam set screw							Zigzag width lever adjusting screw
29.	Z-6157	Arm shaft bushing (2)							Zigzag width lever adjusting screw nut (2 pcs.)
30.	Z-5862	Hand wheel bushing							Zigzag width lever adjusting screw
31.	H-1148	Hand wheel bushing set pin							Needle bar driving rod (compl.)
32.	L-4123	Balance weight							Zigzag width link step screw
33.	L-6113	Balance weight set screw (2 pcs.)							Zigzag width rod spring
34.	Z-5861	Hand wheel							Needle bar driving rod spring
35.	Z-4519	Clutch							Cam contact shaft collar
36.	H-1284	Clutch set screw (3 pcs.)							Cam contact shaft collar set screw (2 pcs.)
37.	Z-4518	Clutch motion washer							Cam contact shaft fastening screw (1)
38.	Z-4510	Clutch motion (compl.)							
39.	Z-4515	Clutch motion set screw (2 pcs.)							
40.	Z-4517	Cap							
41.	Z-5700	Cam door (RZ-777)							
		Cam door (RICCAR-777)							
		(41)							
42.	Z-5704	Cam door spring washer							
43.	Z-5710	Cam contact detaching lever (compl.)							
44.	H-1272	Cam contact detaching lever set screw (1)							
45.	Z-1154	Cam contact detaching lever set screw (2)							
46.	Z-5670	Holder (compl.)							
	(47.	Z-5681	Worm gear						
	[48.	Z-5690	Cam shaft (compl.)						
49.	H-1174	Holder set screw							
50.	Z-5673	Holder adjusting screw							
51.	L-6151	Holder adjusting screw nut							
52.	Z-5672	Holder supporting pin							
53.	H-1069	Holder supporting pin set screw							
54.	Z-5830	Zigzag width regulating dial (compl.)							
55.	L-2056	Zigzag width regulating dial set screw							
56.	Z-5775	Needle position selector dial							
57.	L-4123	Needle position selector dial set screw (2 pcs.)							
58.	Z-5773	Zigzag width regulating dial shaft							
59.	Z-5772	Needle position selector dial shaft							
60.	Z-5781	Dial positioner (compl.)							
61.	Z-1363	Dial positioner set screw (2 pcs.)							
62.	Z-5783	Dial positioner spring							
63.	Z-5791	Needle position regulating cam							
64.	Z-1154	Needle position regulating cam set screw (2 pcs.)							
65.	Z-5801	Buttonholer feed cam							
66.	Z-1154	Buttonholer feed cam set screw (2 pcs.)							
67.	Z-5811	Buttonholer zigzag width regulating cam							
68.	Z-1154	Buttonholer zigzag width regulating cam set screw (2 pcs.)							
69.	Z-5821	Zigzag width regulating cam							
70.	H-1174	Cam door spring washer							
71.	Z-5833	Cam contact detaching lever (compl.)							
72.	Z-5774	Cam contact detaching lever set screw (1)							
73.	Z-1078	Cam contact detaching lever set screw (2)							
74.	Z-5723	Holder (compl.)							
75.	Z-5721	Worm gear							
76.	Z-6308	Cam shaft (compl.)							
77.	Z-5724	Holder set screw							
78.	Z-5725	Holder adjusting screw							
79.	Z-5764	Holder adjusting screw nut							
80.	Z-5765	Holder supporting pin							
81.	L-4036	Holder supporting pin set screw							
82.	Z-5762	Zigzag width regulating dial (compl.)							
83.	L-4036	Zigzag width regulating dial set screw							
84.	Z-5730	Needle position conductor (compl.)							
	[85.	Z-5736	Zigzag width connecting fork						
	[86.	Z-5733	Zigzag width controller						
	87.	L-6017	Zigzag width controller slide block stopper set screw						
88.	Z-5732	Needle position conductor adjusting screw							
89.	H-1263	Needle position conductor adjusting screw nut							
90.	Z-5763	Needle position conductor spring							
91.	Z-5741	Buttonholer feed lever							
92.	Z-5673	Buttonholer feed lever adjusting screw							
93.	H-1263	Buttonholer feed lever adjusting screw nut							
94.	Z-5751	Zigzag width lever							
95.	Z-5673	Zigzag width lever adjusting screw (2 pcs.)							
96.	H-1263	Zigzag width lever adjusting screw nut (2 pcs.)							
97.	Z-5840	Needle bar driving rod (compl.)							
98.	Z-1273	Zigzag width link step screw							
99.	Z-5852	Needle bar driving rod spring							
100.	Z-5761	Cam contact shaft collar							
101.	Z-1175	Cam contact shaft collar set screw (2 pcs.)							
102.	Z-5722	Cam contact shaft fastening screw (1)							

BLOCK-C

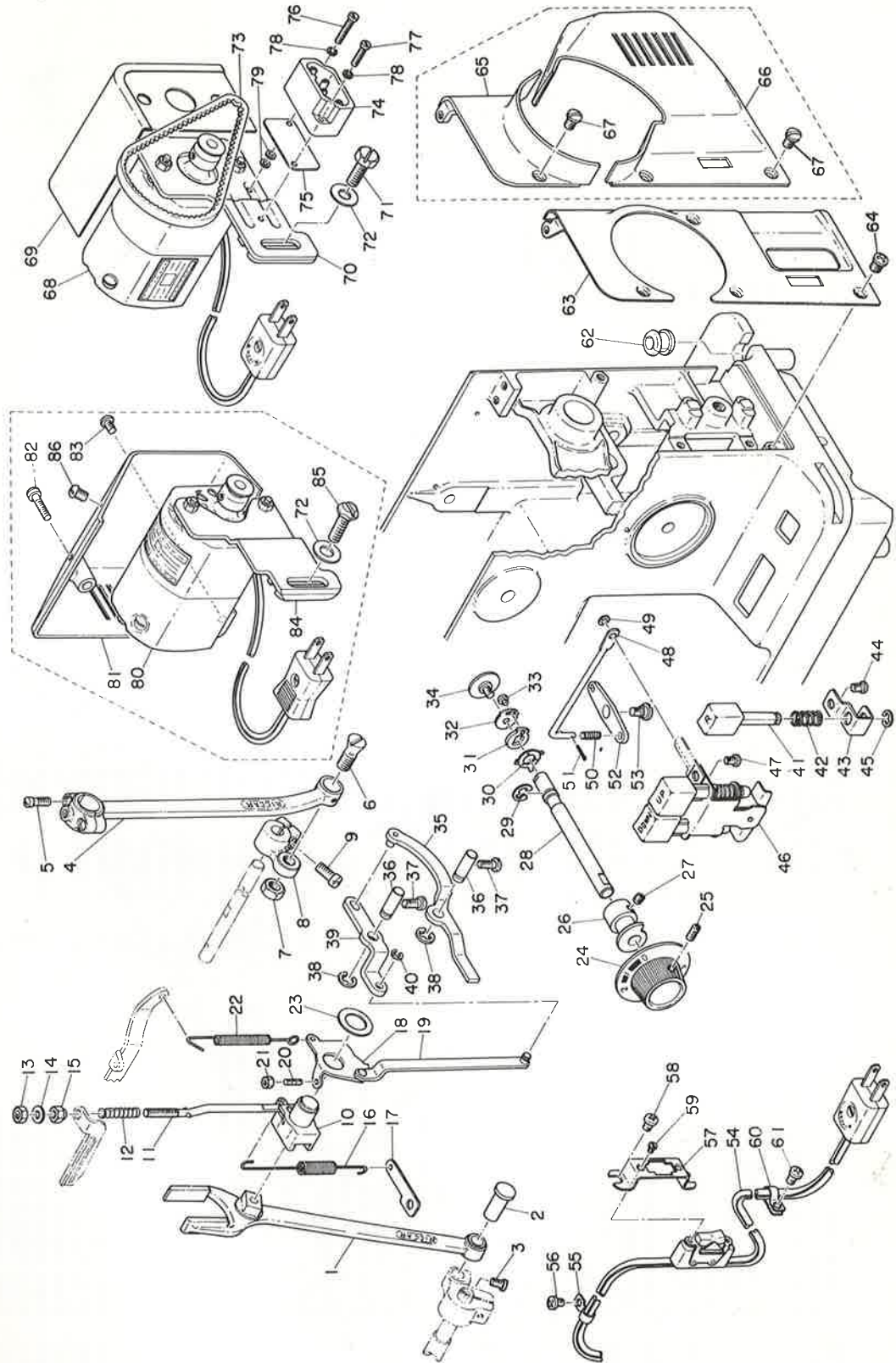

PARTS LIST

1.	Z-6314	Forked rod	35.	Z-5615	Reverse lever (1)	67.	Z-6132	Belt cover (1) (2) set screw (3 pcs.)
2.	Z-6583	Forked rod pin	36.	Z-5618	Reverse lever pin	68.	E-1130	Motor (compl.) (RZ-777)
3.	H-1174	Forked rod pin set screw	37.	L-4124	Reverse lever pin set screw	69.	E-1010	Motor cover
4.	Z-6358	Crank connecting rod	38.	Z-6047	Reverse lever pin set ring	70.	E-1013	Motor bracket
5.	H-1393	Crank connecting rod set screw	39.	Z-5617	Reverse lever (2)	71.	E-1051	Motor bracket clamping screw
6.	H-1163	(2 pcs.)	40.	Z-6193	Reverse lever (2) set ring	72.	E-1052	Motor bracket clamping screw washer
7.	H-1164	Crank connecting rod tapered screw	41.	Z-5621	Reverse sewing button	73.	E-1023	Belt
8.	Z-6359	Crank connecting rod crank	42.	Z-5622	Reverse sewing button spring	74.		Consent
9.	H-1243	Crank connecting rod crank set screw	43.	Z-5623	Reverse sewing button supporting plate	75.		Consent inserting plate
10.	Z-5600	Feed regulator (compl.)	44.	L-4036	Reverse sewing button supporting plate set screw	76.		Consent set screw (1)
[11.	Z-5603	Feed interlocking rod]	45.	Z-6047	Reverse sewing button set washer	77.		Consent set screw (2)
12.	Z-6045	Feed interlocking rod spring	46.	Z-5660	Drop feed (compl.)	78.		Consent set screw washer (2 pcs.)
13.	Z-5605	Feed adjusting nut	47.	L-4036	Drop feed supporting plate set screw (2 pcs.)	79.		Consent washer (2 pcs.)
14.	Z-5608	Feed adjusting stopper washer	48.	Z-5667	Drop feed connecting bar	80.	E-1140	Motor (compl.) (RICCAR-777)
15.	L-6151	Feed adjusting lock nut	49.	Z-6193	Drop feed connecting bar set ring	81.	Z-5411	Motor cover
16.	Z-5614	Reverse spring	50.	Z-6377	Drop feed connecting bar spring	82.	Z-2307	Motor cover set screw (1)
17.	Z-5555	Reverse spring holder	51.	L-6216	Drop feed connecting bar set pin	83.	Z-6132	Motor cover set screw (2)
18.	Z-5610	Feed regulator plate (compl.)	52.	Z-6378	Drop feed regulating crank	84.	E-1019	Motor bracket
[19.	Z-5612	Reverse link]	53.	Z-6125	Drop feed regulating crank step screw	85.	E-5412	Motor bracket clamping screw
20.	Z-5619	Feed regulator plate adjusting screw	54.	Z-5890	Switch cord (compl.)	86.	Z-6041	Belt cover set screw
21.	H-1263	Feed regulator plate adjusting screw nut	55.	Z-5898	Cord holder (1)			
22.	Z-5743	Buttonholder feed lever spring	56.	L-4036	Cord holder (1) set screw			
23.	Z-5554	Feed regulator bushing washer	57.	Z-5899	Switch bracket			
24.	Z-5630	Feed regulator dial	58.	L-4036	Switch bracket set screw (2 pcs.)			
25.	L-6042	Feed regulator dial set screw	59.	Z-2417	Switch set screw (2 pcs.)			
26.	Z-5651	Feed regulating cam	60.	Z-5932	Cord holder (2)			
27.	Z-1154	Feed regulating cam set screw	61.	L-4036	Cord holder (2) set screw			
28.	Z-5641	Feed regulator shaft	62.	Z-5927	Rubber bushing			
29.	Z-6308	Feed regulator shaft set washer	63.	Z-5863	Back cover plate (RZ-777)			
30.	Z-6349	Feed regulating stopper spring	64.	L-4036	Back cover plate set screw (4 pcs.)			
31.	Z-5653	Feed regulating stopper (1)	65.	Z-5413	Belt cover (1) (RICCAR-777)			
32.	Z-5654	Feed regulating stopper (2)	66.	Z-5414	Belt cover (2)			
33.	Z-6348	Feed regulating stopper adjusting screw						
34.	Z-6351	Feed regulating stopper fastening screw						

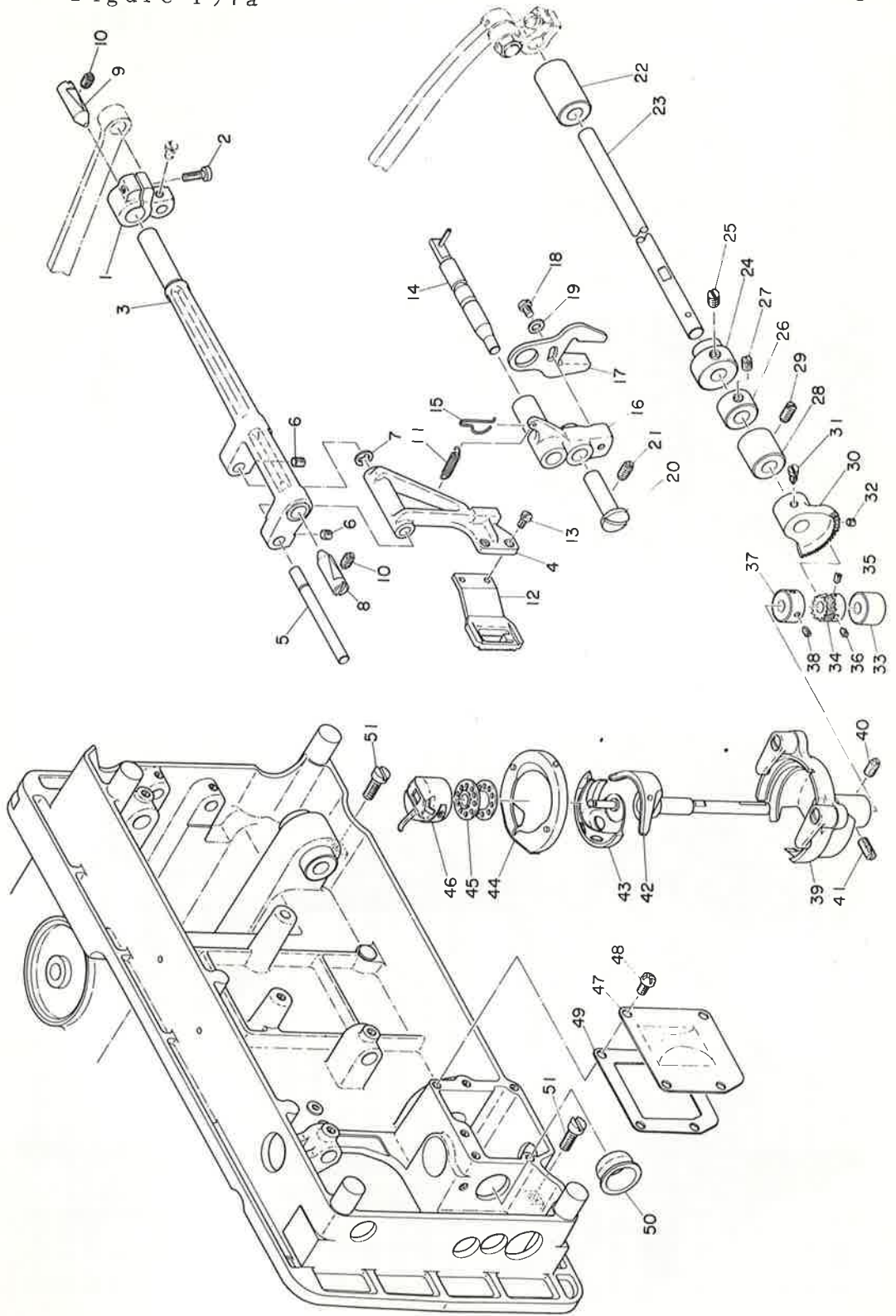

BLOCK-D

66. Z-5414 Belt cover (2)

fastening screw

P A R T S L I S T

1.	Z-6352	Feed rock shaft crank			
2.	H-1243	Feed rock shaft crank set screw			
3.	Z-5940	Feed rock shaft (compl.)			
	[4.	Feed bar)			
	[5.	Feed bar shaft)			
6.	H-1174	Feed bar shaft set screw (2 pcs.)			
	[7.	Feed bar shaft set ring)			
8.	L-6115	Center bar (1)			
9.	L-6116	Center bar (2)			
10.	H-1069	Center bar set screw (2 pcs.)			
11.	Z-2373	Feed bar spring			
12.	Z-6357	Feed dog			
13.	H-1234	Feed dog set screw (2 pcs.)			
14.	Z-6503	Feed lifting regulator bar (with pin)			
15.	Z-6505	Feed lifting regulator bar spring			
16.	Z-2374	Feed lifting rock crank			
17.	Z-6367	Feed lifting rock crank fork			
18.	H-1383	Feed lifting rock crank fork set screw			
19.	Z-2252	Feed lifting rock crank fork set screw washer			
20.	Z-6369	Feed lifting rock crank pin			
21.	H-1069	Feed lifting rock crank pin set screw			
22.	Z-6363	Oscillating shaft bushing (2)			
23.	Z-6361	Oscillating shaft			
24.	Z-6366	Feed lifting cam			
25.	H-1069	Feed lifting cam set screw (2 pcs.)			
26.	Z-6364	Oscillating shaft collar			
			27.	H-1063	Oscillating shaft collar set screw (2 pcs.)
			28.	Z-6362	Oscillating shaft bushing (1)
			29.	H-1069	Oscillating shaft bushing (1) set screw
			30.	Z-6365	Oscillating shaft gear
			31.	Z-6572	Oscillating shaft gear set screw
			32.	H-1063	Oscillating shaft gear set screw
			33.	Z-6383	Shuttle driver shaft bushing
			34.	Z-6381	Shuttle driver shaft gear
			35.	Z-1154	Shuttle driver shaft gear set screw (1)
			36.	Z-6388	Shuttle driver shaft gear set screw (2)
			37.	Z-6401	Open shuttle race holder collar
			38.	Z-1154	Open shuttle race holder collar set screw (2 pcs.)
			39.	Z-6390	Open shuttle race (compl.)
			40.	H-1069	Open shuttle race set screw (1)
			41.	Z-2379	Open shuttle race set screw (2)
			42.	Z-6382	Shuttle driver (compl.)
			43.	Z-1389	Shuttle hook
			44.	Z-6393	Shuttle hook holder
			45.	H-1229	Bobbin
			46.	Z-6450	Bobbin case
			47.	Z-2376	Gear box cap (1)
			48.	L-4036	Gear box cap set screw (4 pcs.)
			49.	Z-2377	Gear box cap packing
			50.	Z-6385	Gear box cap (2)
			51.	H-1159	Hinge set screw (2 pcs.)

LIST OF PARTS

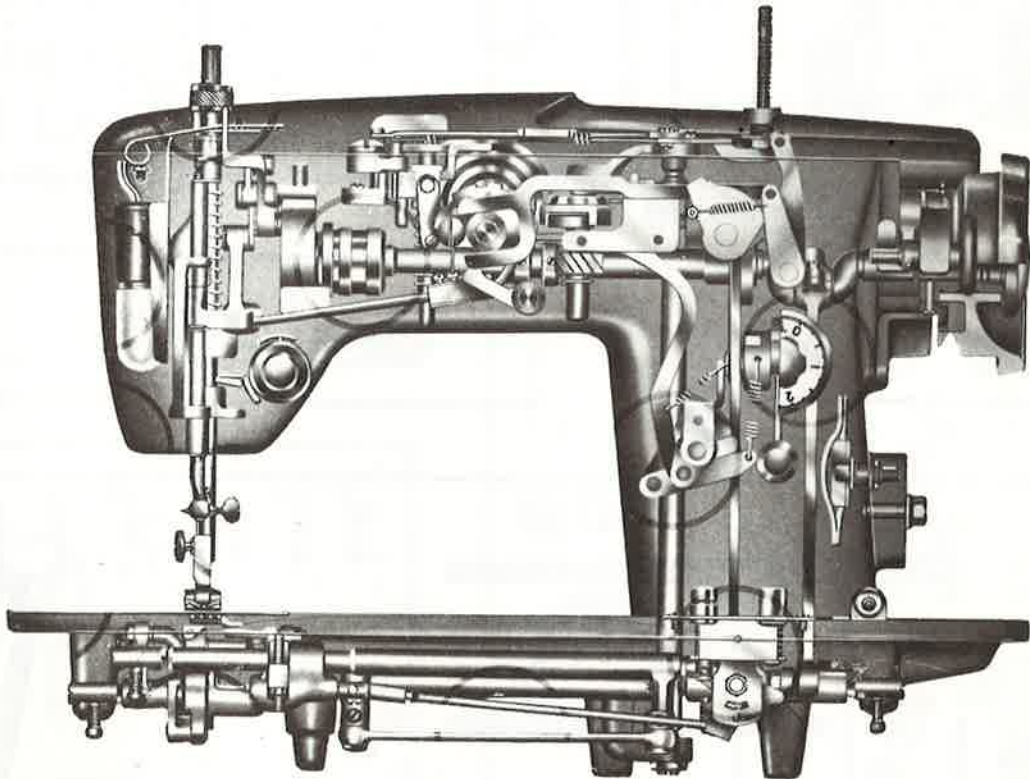
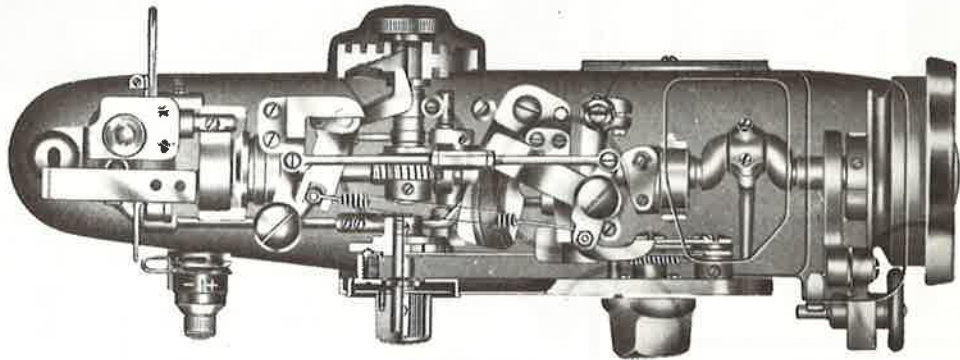
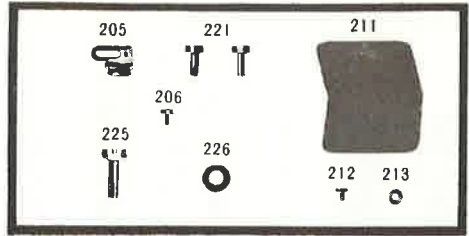

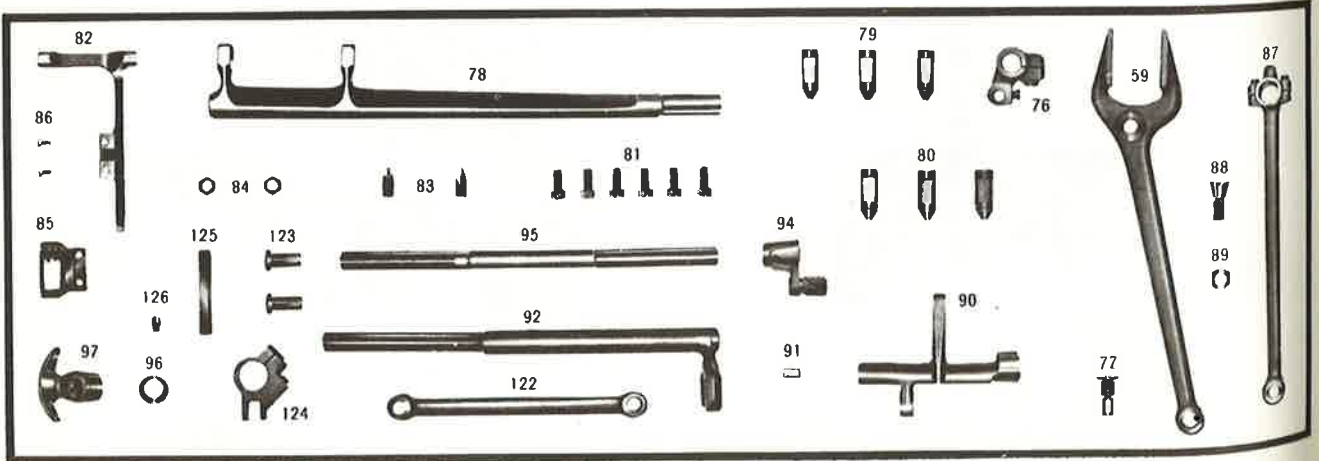
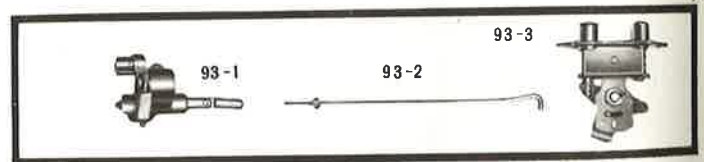
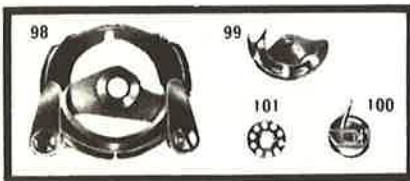
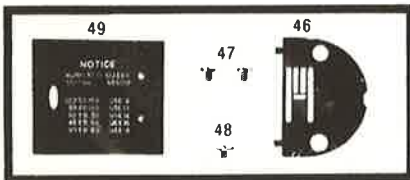
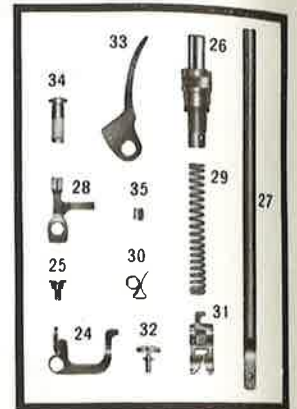
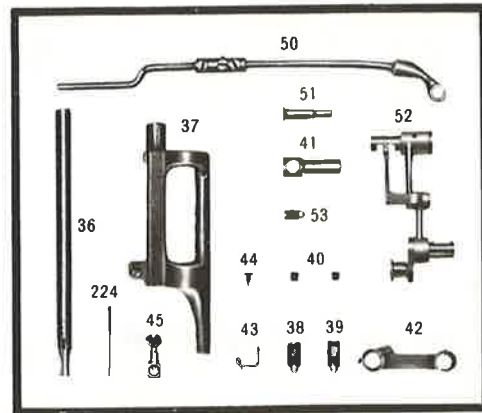
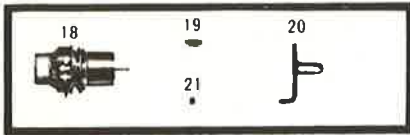
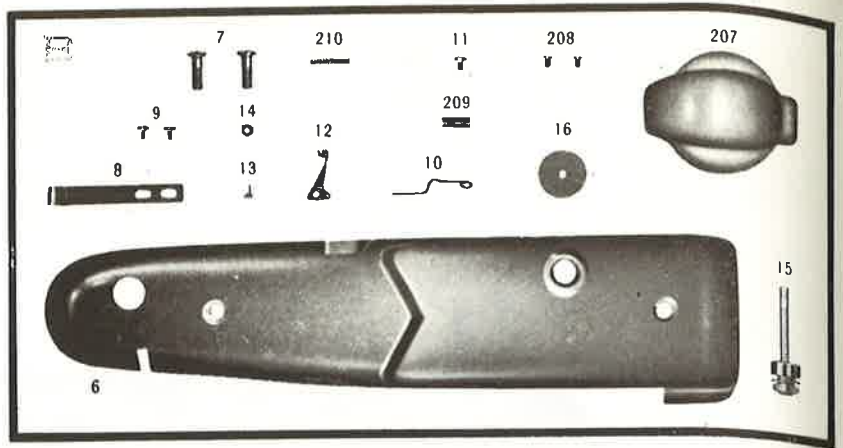
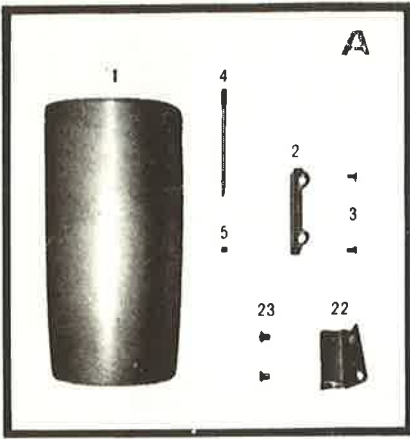

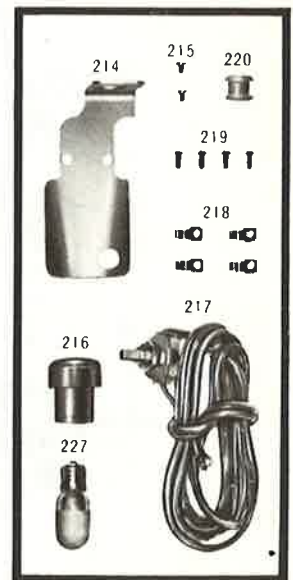
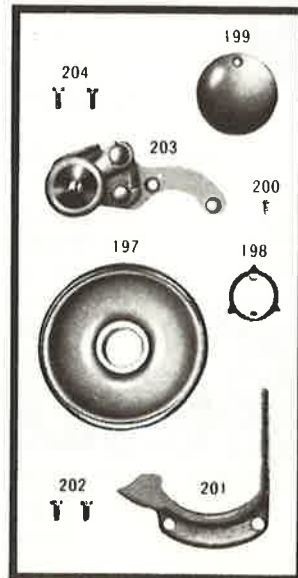
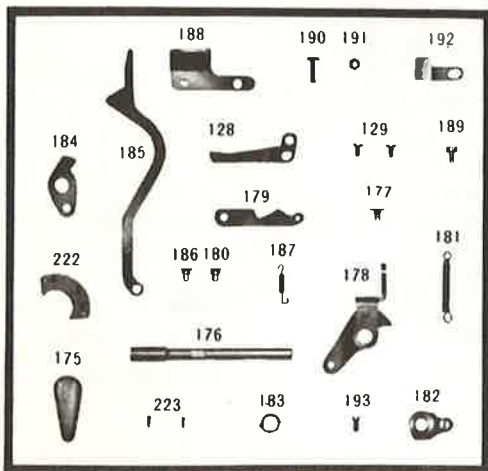
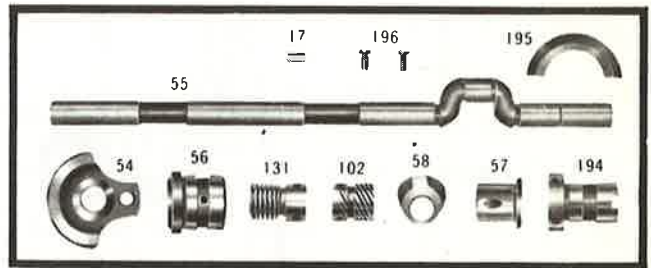
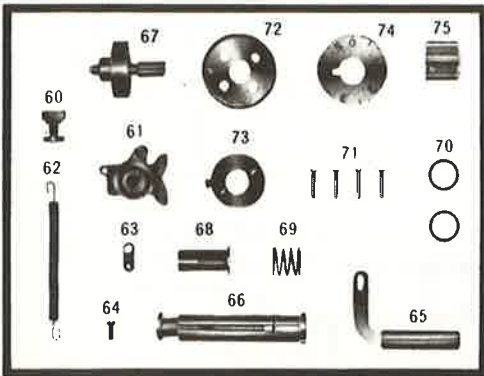
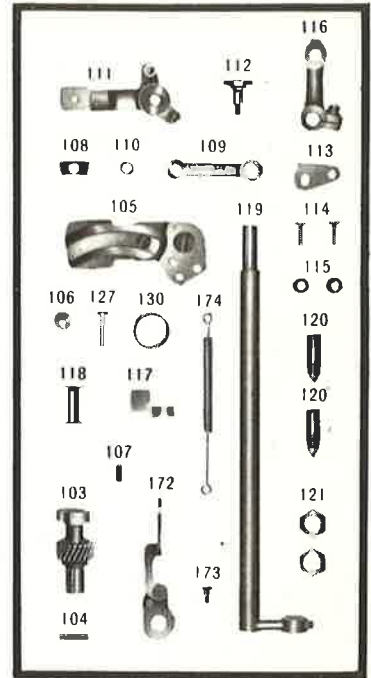
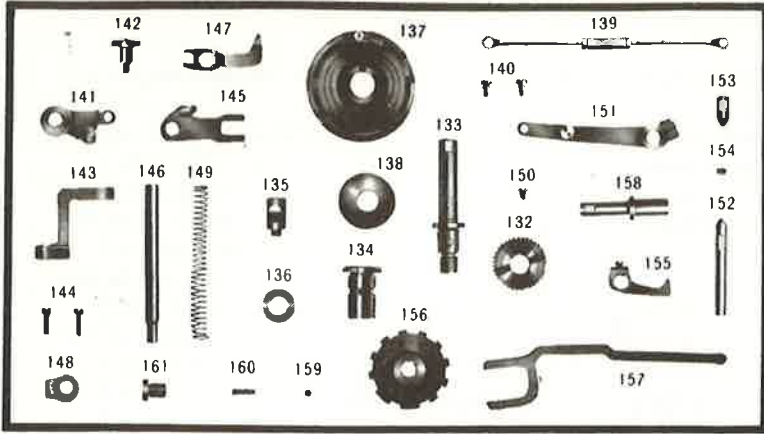

The Adler Automatic.

The Adler is another example of the excellent workmanship European companies build into their machines. They are precision made with extremely close tolerances at all vital spots and are made to last for many years.

Figure 198

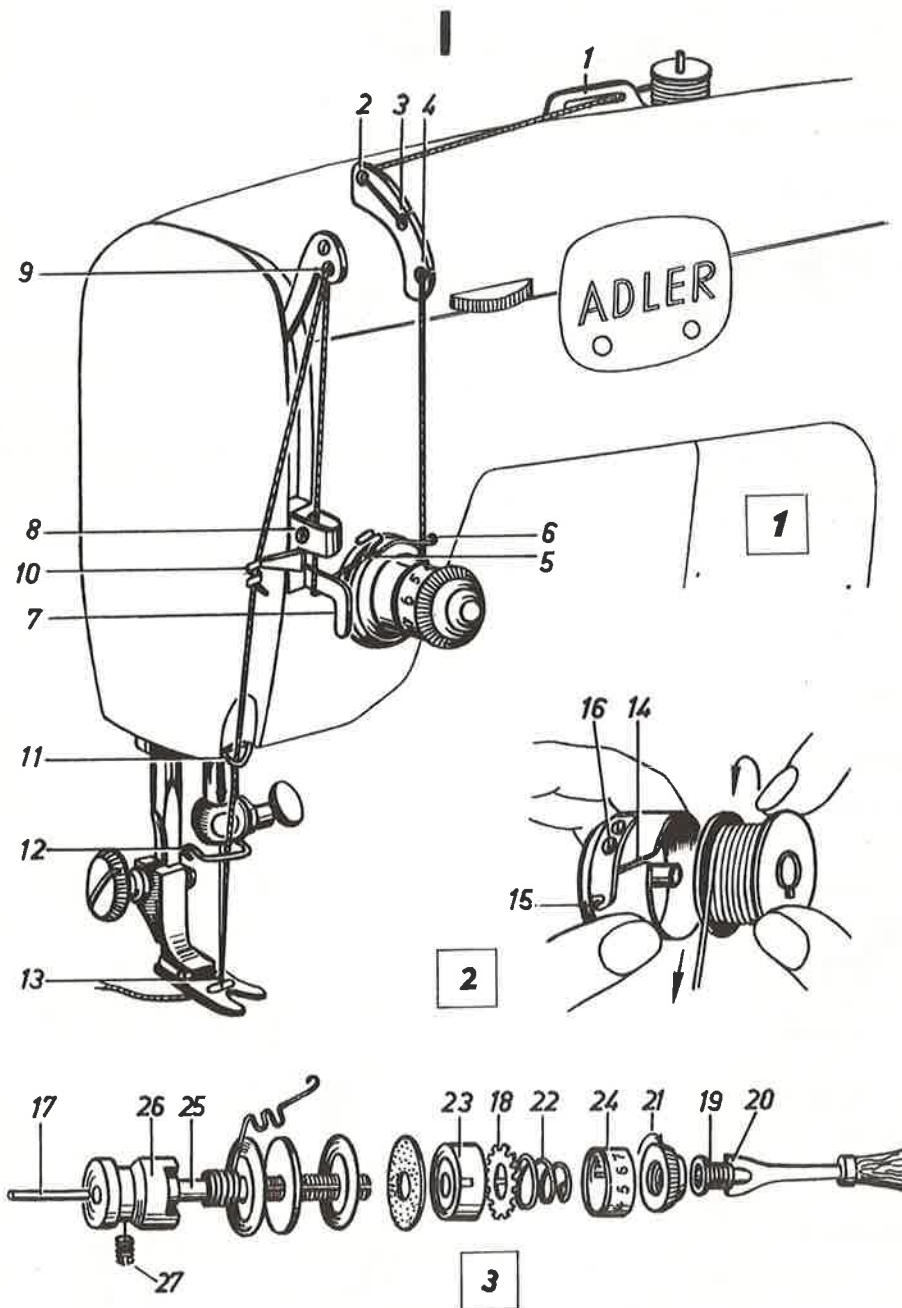

Upper tension.

Steps 1 thru 13 illustrate correct threading of the Adler 289A-589A automatic.

Nothing new here except excellent thread control at points 2, 3 and 4.

Take-up lever is drilled for double needle operation.

Sewing mechanism is transverse hook, therefore needle threads from the front. Flat shank of needle faces away from the operator.

To dismantle tension assembly, a special screwdriver with cut-out blade must be used.

Hold threaded sleeve(19, figure 198, securely, while turning knurled knob (21), counterclockwise with a pair of pliers.

Remove balance of components according to sub-assembly 3, figure 198.

Tension control is made by adjusting numbered dial.

0 setting is for extremely loose upper tension.

10 setting is for extremely tight upper tension.

To tighten beyond setting 10, turn threaded sleeve inward as needed. Lock in place with special screwdriver.

If tension discs are thread cut, smooth with emery paper.

If damage is too severe, replace the tension discs.

If upper thread fails to release when presser bar lifter is activated, check release pin(17).

A broken or bent pin must be replaced.

Check spring adjustment.

Properly adjusted check spring should release the thread as needle enters the material.

To adjust, loosen pin(25), in adjustment sleeve(26).

Release tension pin. (tension components must be removed so tension dials will release far enough for spring to be adjusted.)

If spring has too much check, turn adjustment sleeve counterclockwise as needed.

Reverse the procedure if spring has too little check.

Tighten pin, re-assemble tension components.

Test sew.

If spring is broken or bent, replace it.

The bobbin case.

Correct threading of bobbin case is illustrated in figure 198, sub-assembly 2.

Thread comes off bobbin counterclockwise into notch 14, under spring and into notch 15.

Bobbin tension is adjusted by turning adjusting screw(16).

For more lower thread tension, turn screw(16), clockwise as needed.

For less bobbin thread tension, turn screw counterclockwise.

If spring fails to hold tension, remove and inspect closely.

A thread-cut bobbin case spring should be replaced.

Clean lint and dirt from the area.

Oil all moving parts one every service call, or once a month.

Service tip: When new parts are needed, always replace them.

Always insert a new needle when servicing a sewing machine.

Skeleton showing zig zag and needle bar assembly.

Figure 199

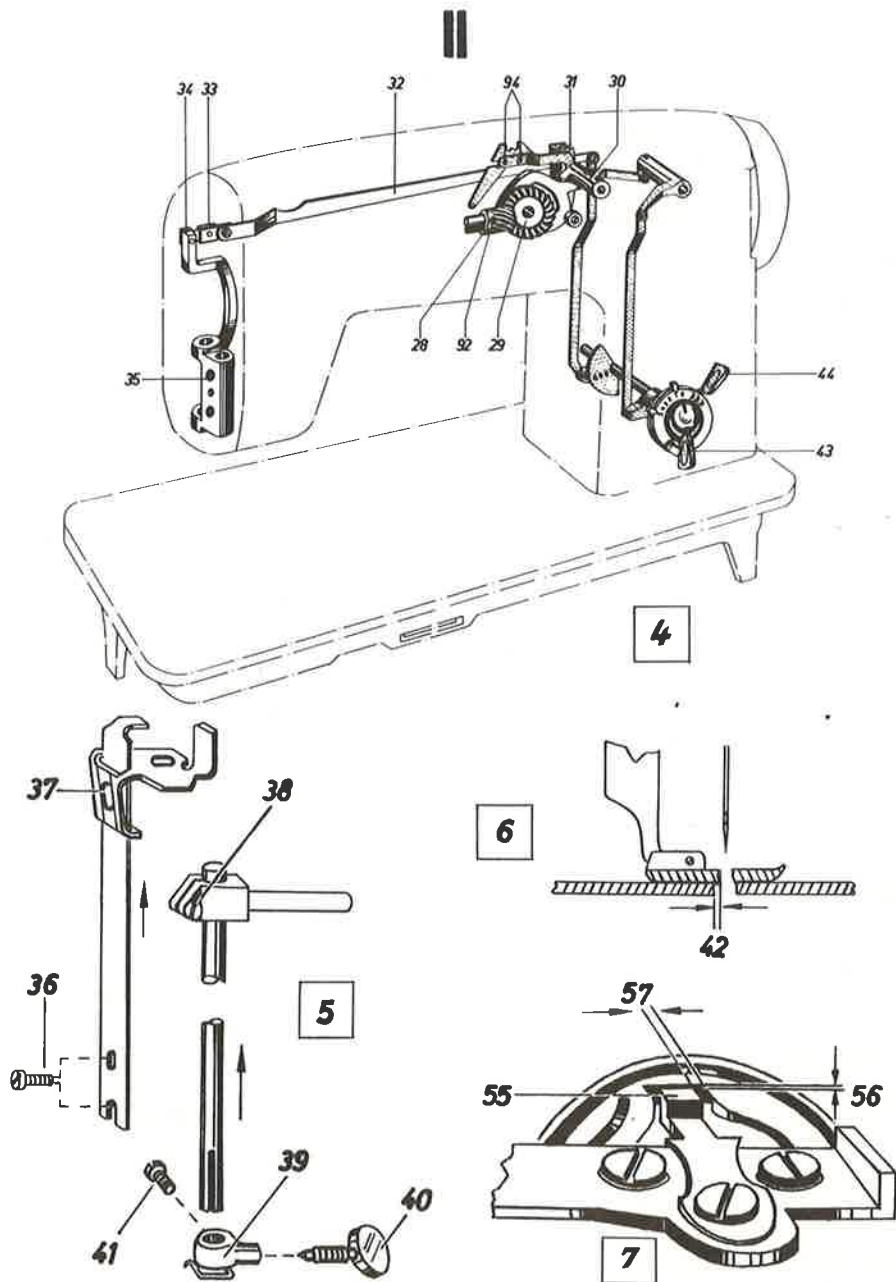

Needle bar components.

1. Needle bar rocker(35).
2. Needle bar.
3. Block and adjusting screw(38).
4. Needle clamp and screw(39-40).
5. Needle stop screw(41).
6. Quick adjuster and set screws(36-37).
7. Needle(not illustrated).

To remove needle bar, loosen screws(36, figure 199) on bar adjuster.
 Remove the adjuster by pulling out toward the top.
 Loosen screw(38).
 Remove needle clamp, screw and stop screw.
 Pull needle bar out top of machine.
 Replace new bar in reverse order.
 Later text covers timing.

The needle stop(41) prevents needle from sliding too far up into bar.
 If the stop screw is broken, or missing, machine will skip stitches.

Sub-assembly 6 illustrates needle guard in presser foot.
 If groove becomes dirty, machine may break thread.

Zig zag system.

Lever(43) changes the width of zig zag
 When lever is changed it changes position of width link(31).
 Sidewise motion is caused when machine turns and lever(43) is activated.
 Main shaft turns gears(28-29), which turns stitch width fork(30) and link(31)
 which connects with link(32) with link and rod(33 & 34) and moves rocker.
 The rocker fits over needle bar and moves sidewise when activated.

Needle bar position lever.

The needle position lever(44) changes needle from left, center and right,
 straight sewing position. Zig zag will operate from all three positions.

If needle bar acts erratically when zig zag lever is activated, check gear
 (29). If mesh isn't accurate, loosen screw(92) and move until correct. The
 screw is accesible through a hole in rear of machine.

Double needle.

The double needle is adaptable by using a twin needle clamp.
 Before using, check timing with hook and be sure clearance is correct.

Sub-assembly 7.

Sub-assembly 7 illustrates bobbin case holder and lug(55, 56).
 Screw should be adjusted so space(57), allows thread through easily.
 Over-adjustment will cause thread to break.
 Under-adjustment will cause a lot of noise and loose thread control.

Needle.

Drive assembly(upper and lower) and feed assembly.

Figure 200

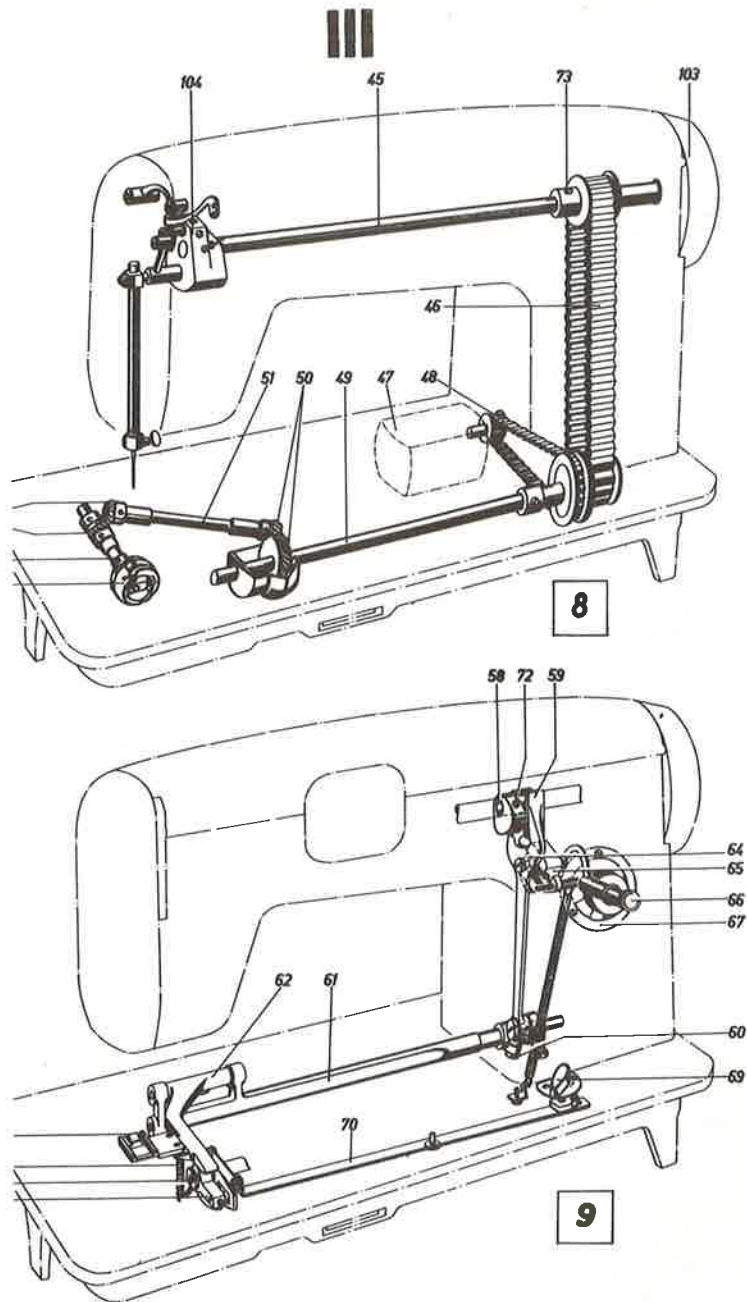

The hook and lower drive.

The lower drive is activated directly from the motor(47) with belt(48) and lower assembly is timed at this point.

The hook is driven from shafts(49 & 51) by two sets of helical gears.

The Adler hook functions in same manner as other high speed rotarys do, and is one of quieter machines on the market.

The hook catches the upper thread as loop is thrown when needle is on up-stroke.

If hook contains needle strike marks, smooth with emery cloth. If marks are too severe, replace the part.

Timing is covered in later text.

The feed mechanism. (Figure 200).

The feed fork(59) runs off cam(58) which is attached to upper main shaft, and is controlled by length of stitch knob(66).

The fork connects lower feed mechanism at feed block(60).

Fork action transmits through feed bar and rocker shaft(61 and 62) to the feed dog.

To raise height of feed dog, loosen set screw on rocker cam and adjust it as needed. Proper height is 1/32" above level of needle plate.

Timing the needle bar and feed dog.(figure 201).

To time feed dog, loosen set screw(73, figure 200).

Turn balance wheel until feed makes motion like 10, figure 201.

Hold the belt and turn balance wheel until needle and feed dog are at highest point.

Tighten set screw and test sew.

Correct motion of feed dog is: forward motion(74), dropping of dog(75). Return to starting position(76), and upward motion of feed dog(77).

Timing the needle bar.

Lower needle to it's lowest position(sub-assembly 12, figure 201).

Take-up arm should be half-way on downward stroke.

Tip of hook should be at 45 degrees away from needle.

Feed dog should be at lowest position, starting toward starting point.

Loosen screw(36) and turn balance wheel until hook enters loop.

Move needle bar up slightly, until top of needle eye is .04" below hook.

Tighten set screw.

When the needle is set in middle position, clearance between hook point, and needle should be .004".

Disregard gauge shown in sub-assembly 15. Above adjustment will do.

The bobbin case.

The bobbin case holder should fit in place with lug on holder located accurately in notch in lower end of case so feed dog won't strike it.

If bobbin case does contact the feed dog, bend holder downward.

Tension assembly.

The tension is similiar to many models already covered, refer to previous text earlier in this chapter.

Timing, for both needle bar and feed dog.

Figure 201

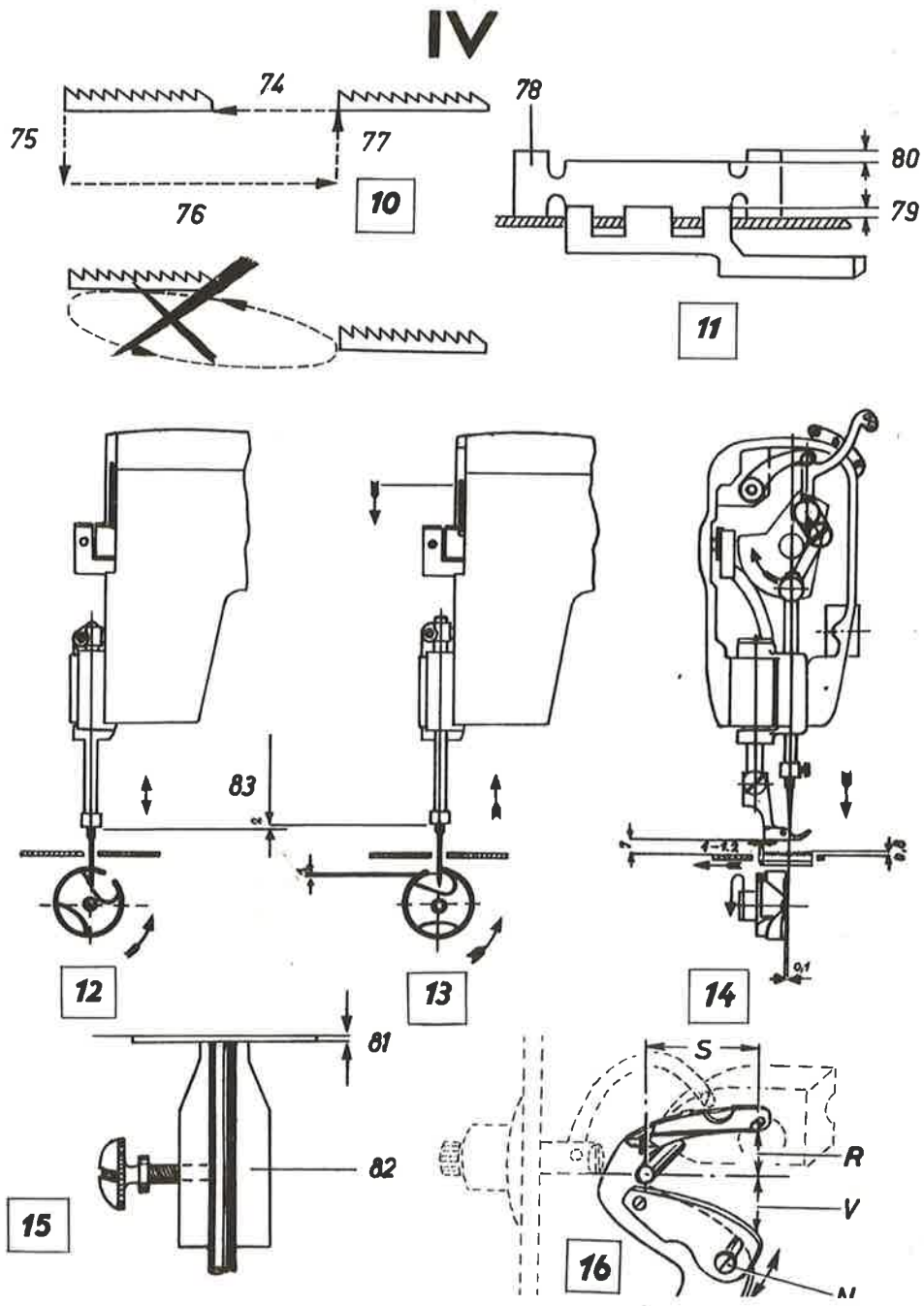

The Automatic assembly.

The automatic unit(sub-assembly 17, figure 202) when activated, controls the width of stitch, position and length of stitch.

The Adler automatic is removable cam type, with three control unit.

When automatic controls are engaged, the manually operated controls become inert and may be re-engaged only after automatic operation ceases.

The automatic unit doesn't alter any manual operational settings.

Service.

If automatic unit becomes extremely noisy, or sews decorative stitches in an erratic manner, remove cover on upper arm.

Inspect gears(84 and 85, figure 202).

If loose, loosen screw(86).

Adjust screws(87 and 88), until gears mesh properly.

Adjusting stitch width mechanism.

When stitch width mechanism is properly adjusted, needle should lower in motion illustrated in figure 18, of figure 202.

Needle must enter cloth in straight downward motion.

To adjust, loosen screw(92), figure 199, and move bevel gear back.

Turn bevel gear(29) until properly adjusted. Tighten screw.

Adjusting automatic stitch width mechanism.

Engage automatic stitch width control.

Needle shouldn't swing when in this position.

If needle moves, turn eccentric screw(93) until corrected.

To check zig zag needle position, set automatic stitch position knob on.

Set width control on widest throw.

Disengage the drop feed.

Place a business card under presser foot and lower foot.

Penetrate card at all three positions per drawing 19.

Return stitch width control to 0.

Turn balance wheel and lower needle into center position.

If needle doesn't enter hole in exact spot, loosen screws(94, figure 199), and holding bracket in place, engage lever 44 until needle is properly set.

Tighten set screws(94) and test sew.

If further adjustment is needed, loosen screw(95), hold spring in place as you press the spring into center position of the catch.

Tighten screw(95).

Figure 202

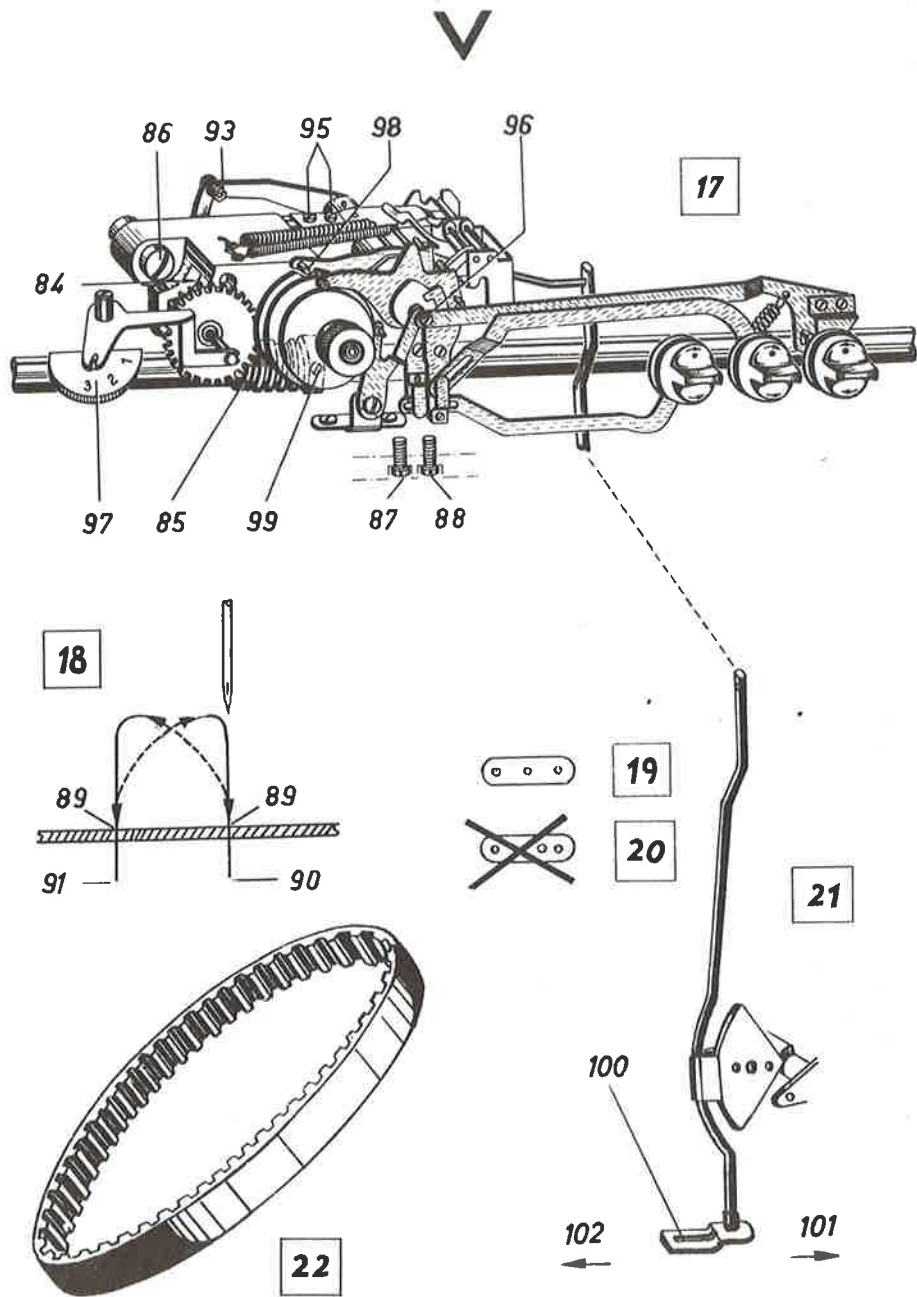

The Elna Supermatic.
Needle clearance-Free Arm



Loosen 4 casing assembly screws.

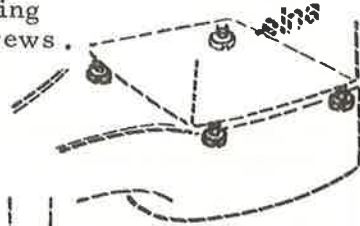

Adjust to proper clearance by moving upper casing in relation to lower casing.

(.002")



Tighten all casing screws.



Elna Disc drive.



Run machine full speed and observe arc of the needle bar.

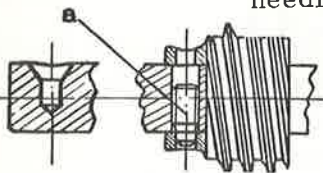

If not swinging properly, loosen screw(a). Loosen worm gear and change it's position until corrected.

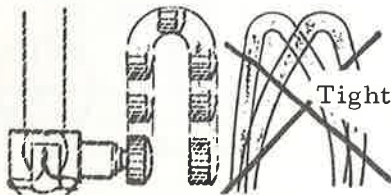

Tighten screw(a).

Needle clearance-Flat Bed

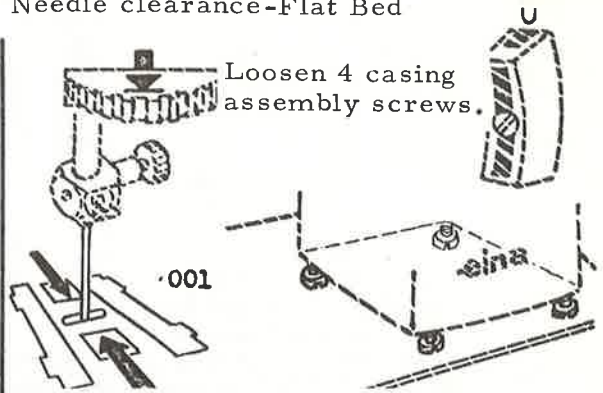

Loosen 4 casing assembly screws.

Loosen 3 of 4 screws slightly and adjust the clearance like #1.

Tighten 3 lower casing screws.

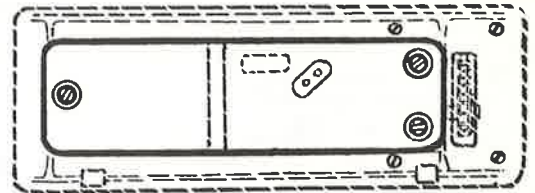

Needle bar swing.



Loosen screw(a) and adjust screw(b) until corrected.

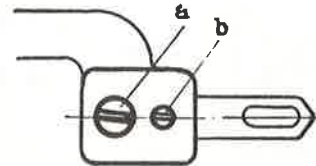

X1 = X2

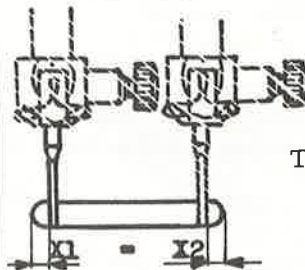

Tighten screw(a).

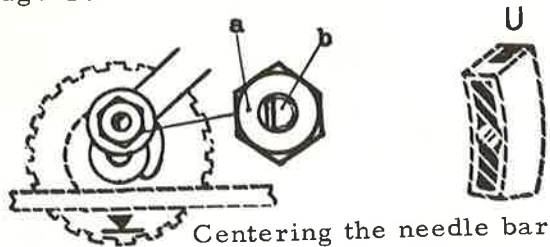

Centering the needle bar

Loosen nut(a) and adjust screw(b) as needed. See X-1/X-2.



The groove on eccentric(b) must be to the left.

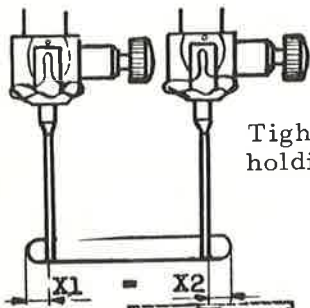

Tighten nut(a) while holding eccentric(b).

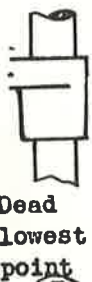

Timing the hook.

Loosen both screws on the driving belt pinion.

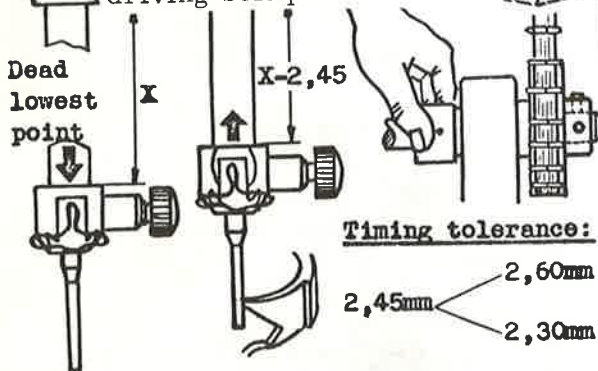

Drop needle to lowest point.

Turn to right as lower shaft is turned direction of operation, and bring hook point around to the needle. Snug the shaft with driving belt pinion and tighten screws. Lower shaft must turn freely.

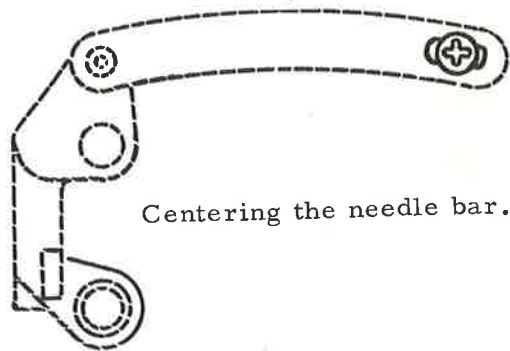

Centering the needle bar.

Loosen screw(a) and adjust the retainer to center of needle hole.

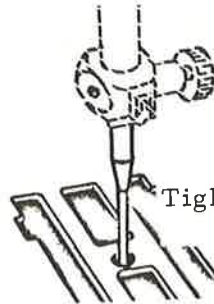

Tighten screw(a).

Setting needle bar height.

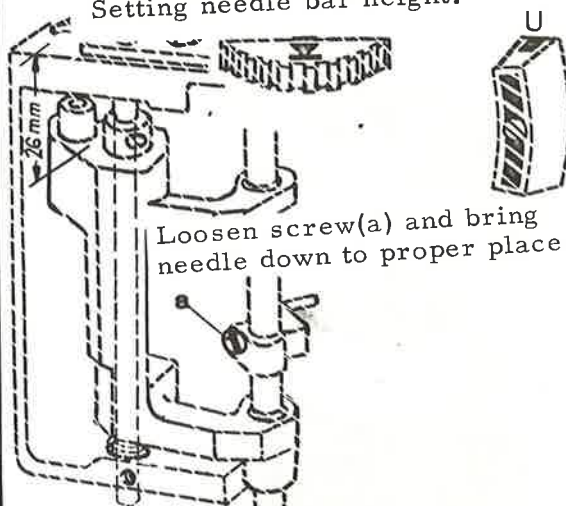

Loosen screw(a) and bring needle down to proper place.

The needle frame (cradle) should be approx. 1" from upper surface of machine. If adjustment needed, push upward manually as needed.



Tighten screw(a).



Needle bar position



Loosen screw(a) until needle bar is loose.

Adjust as needed and tighten screw(a).

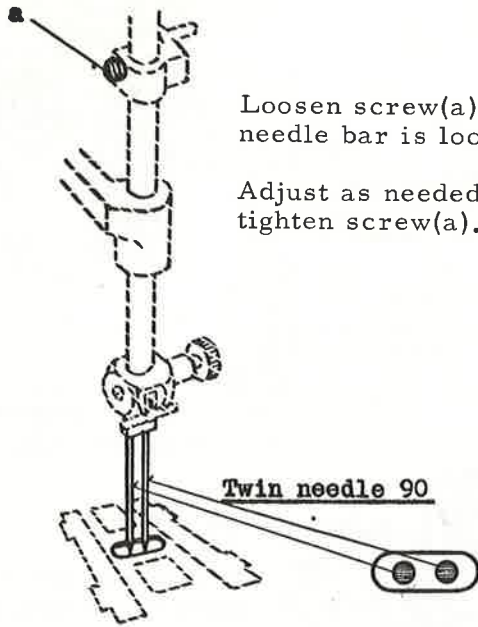

Timing the feed.

Loosen screws(a, b), to disengage feed pinion.

Place take-up arm at highest point.

Turn feed gear until feed dog will continue 1 mm more.

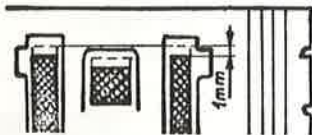

Engage feed pinion so you can tighten both screws while lining it with the center of the feed gear.

Loosen both screws and position as needed.

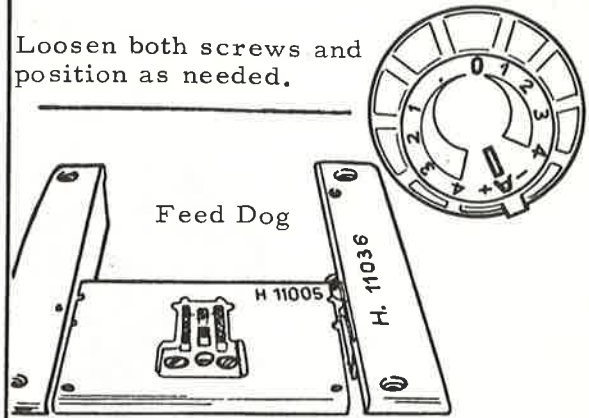

Tighten screws after positioning.

Proper height is 1/32" above needle plate.
To adjust, loosen nut(a) and turn upward.

Check stitch length. Feed dog must not touch plate on long stitch at setting 4.

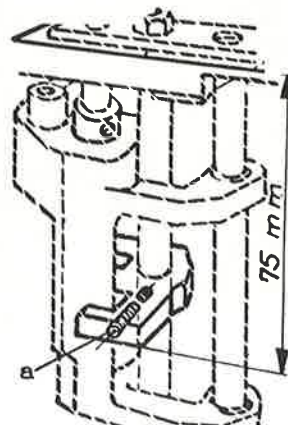

Presser Bar

Loosen screw(a) and drop feed to lowest position. Lower presser foot and hold bar in proper place. Measurement is less than 3" from block to upper cast.

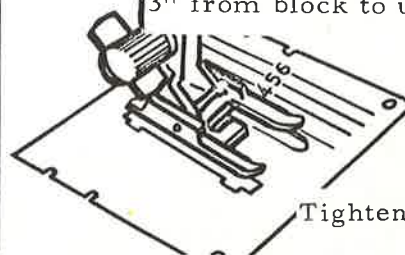

Tighten screw 'a'.

Stitch length

Free screw(a), and loosen(b) just enough to move feed control cam proper direction.

Move in direction of arrow to increase length of stitch.

Backward to decrease.

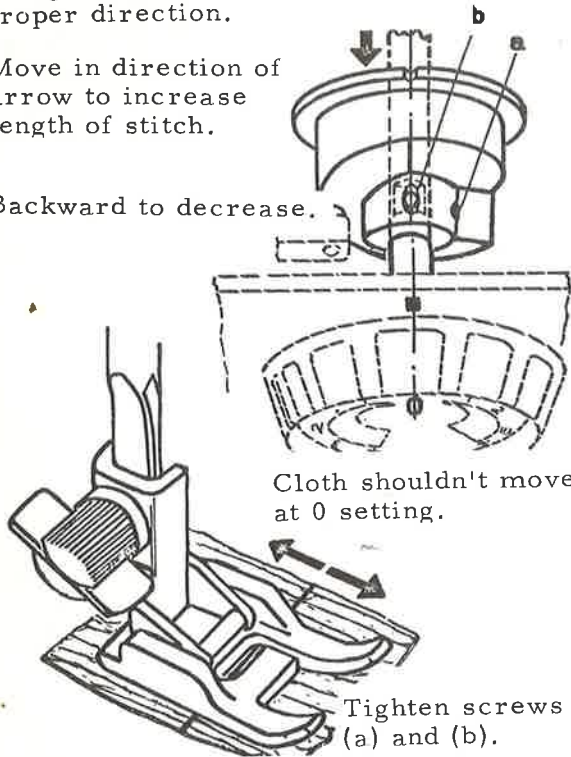

Automatic Buttonhole feed

No double disc in the machine.

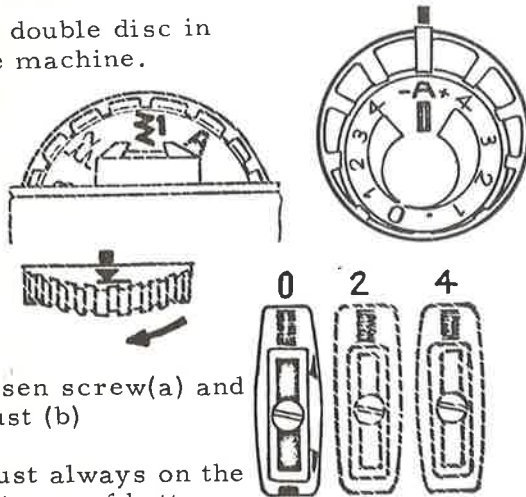

Loosen screw(a) and adjust (b)

Adjust always on the first row of buttonhole.

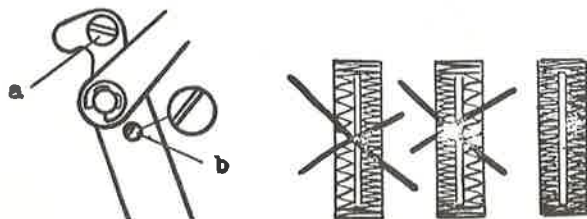

Automatic feed

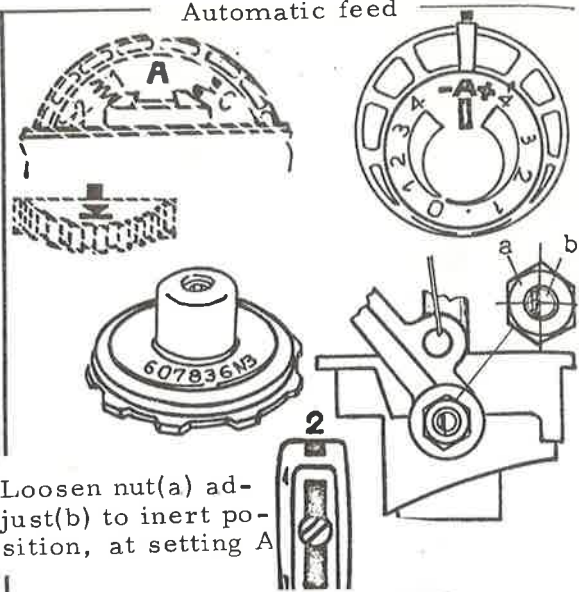

Loosen nut(a) adjust(b) to inert position, at setting A

The eccentric groove must be on the left.

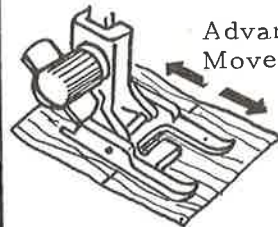

Advance at plus.
Move back at minus.

Advance and return nearly equal length

Tighten screw(a).

No double disc in the machine.

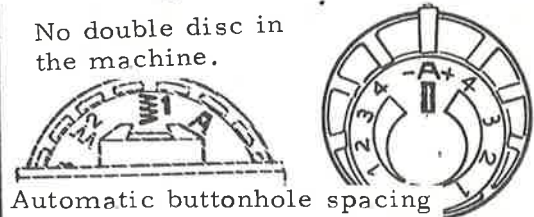

Automatic buttonhole spacing

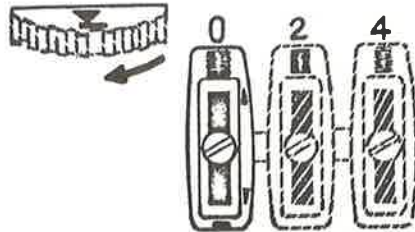

Loosen screw(a) and adjust (b) to obtain ideal spacing.

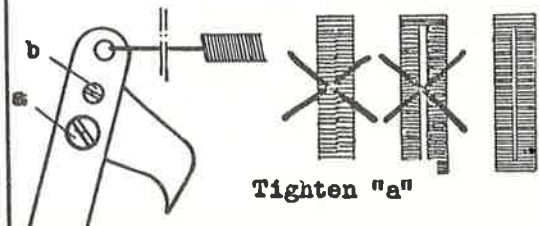

Tighten "a"

Bobbin winder

Loosen flywheel couple knob one half turn

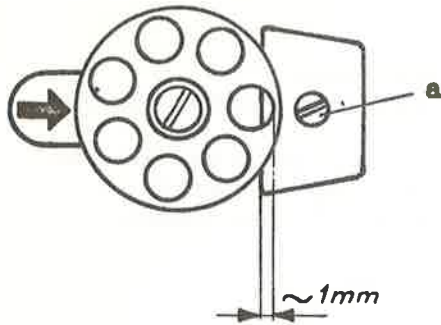

Loosen screw(a) until wheel overlaps .04", of bobbin winder stop.

Tighten screw(a).

Lower tension.

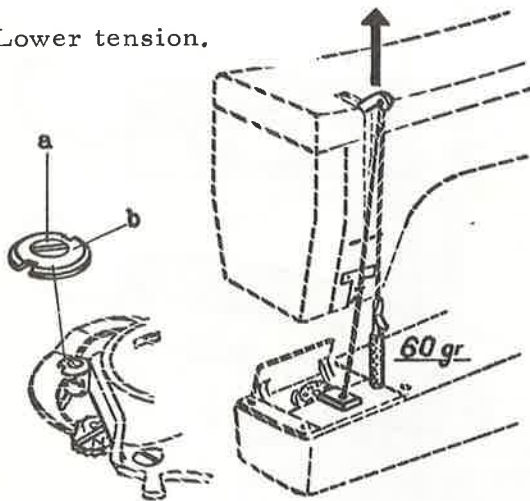

Loosen "b" to



To adjust, loosen screw(a). Adjust screw(b) as needed. Clockwise to increase the tension. Counterclockwise to decrease as needed.

Tighten screw(a).

Upper Tension

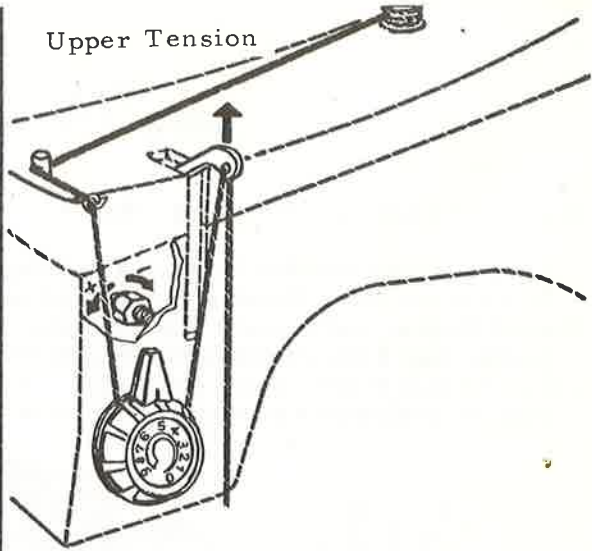

Tension is similar to assemblies already covered.

Turn tension clockwise to adjust as needed. For increase.

Turn tension counterclockwise to decrease the tension.

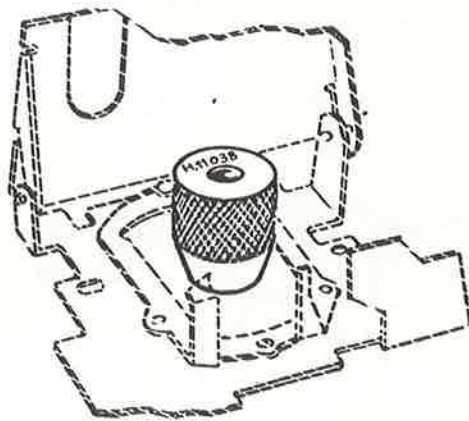

Center separating plate and align rotary hook cover to needle plate

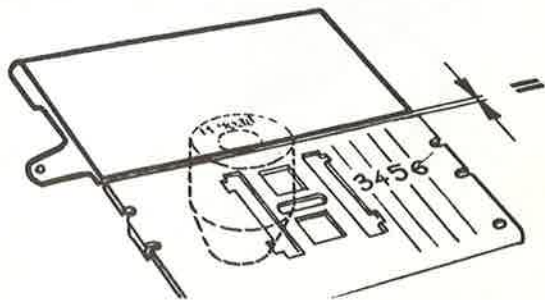

Bobbin winder

Loosen flywheel couple knob
one half turn

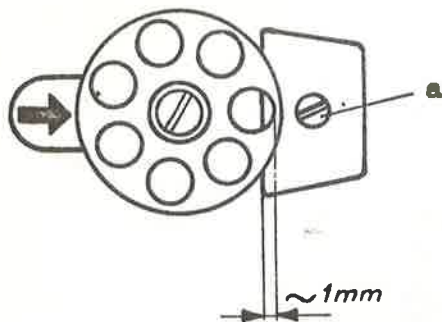

Loosen screw(a) until wheel overlaps .04", of bobbin winder stop.

Tighten screw(a).

Lower tension.

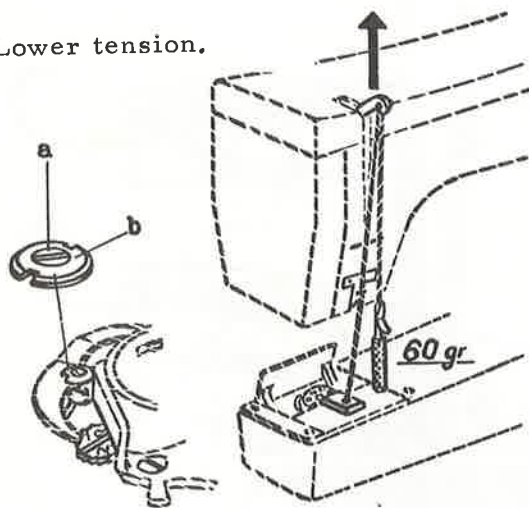

To adjust, loosen screw(a).
Adjust screw(b) as needed.
Clockwise to increase the tension.
Counterclockwise to decrease as needed.

Loosen "b" to



Tighten screw(a).

Upper Tension

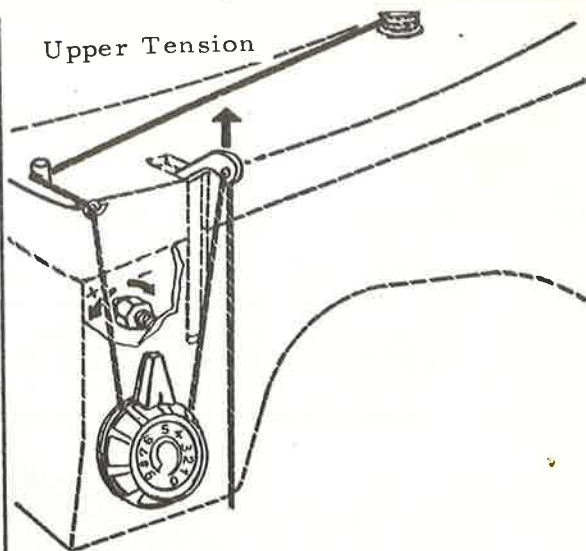

Tension is similar to assemblies already covered.
Turn tension clockwise to adjust as needed. For increase.
Turn tension counterclockwise to decrease the tension.

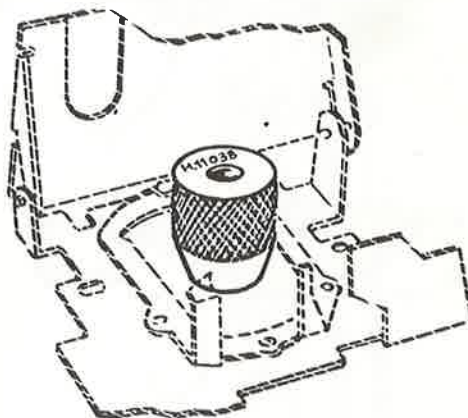

Center separating plate and align rotary hook cover to needle plate

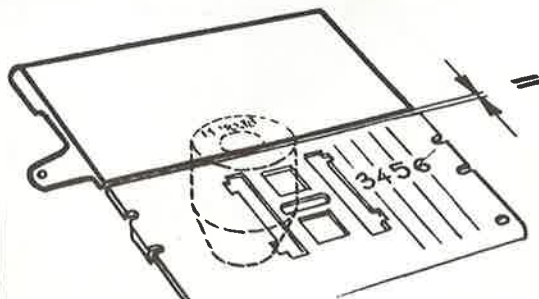

Chapter Seven

Miscellaneous Sewing Machines.

This chapter touches briefly a variety of sewing machines.

Since Free-New Home and National no longer manufacture machines in the United States, we'll cover each slightly.

Latter day Free-Westinghouse and New Home machines can be serviced as Class 15 machines, from chapter 2. For zig zag, see chapter 5 and 6.

Figure 206 shows correct steps in threading a long shuttle New Home.

Figure 215

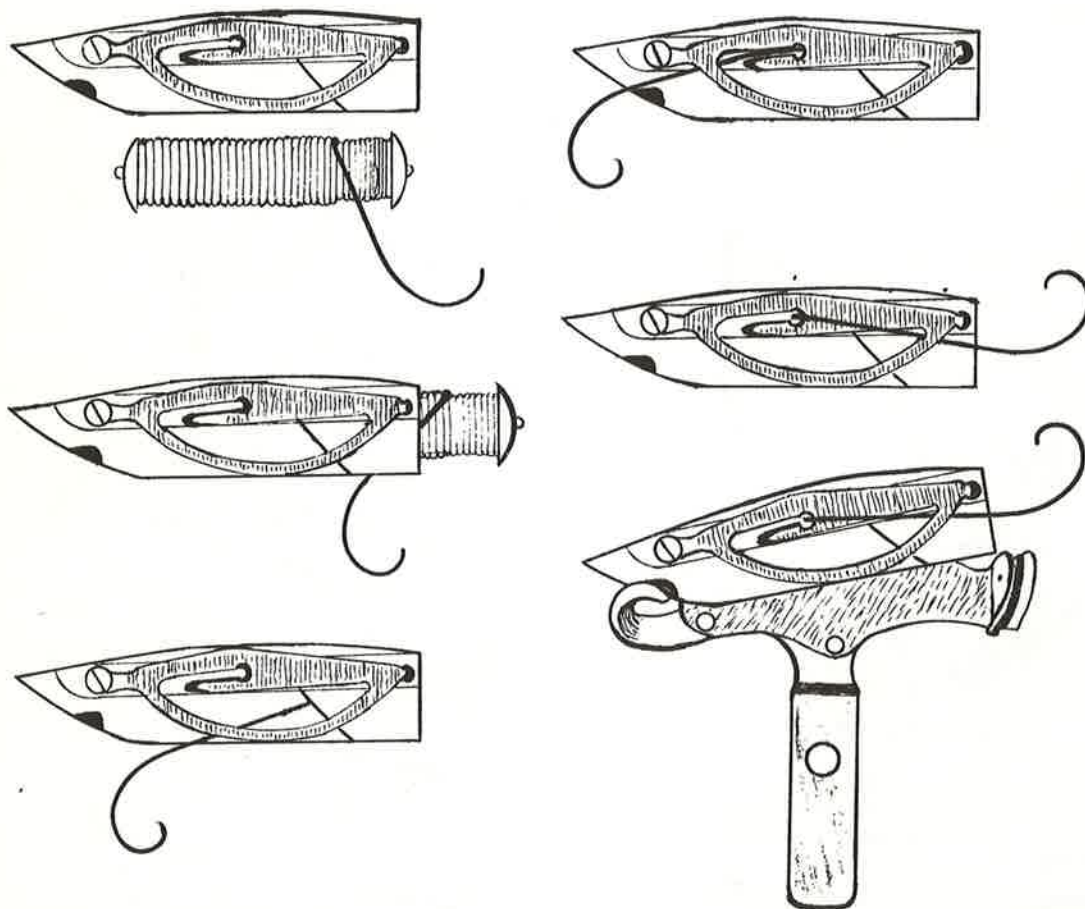
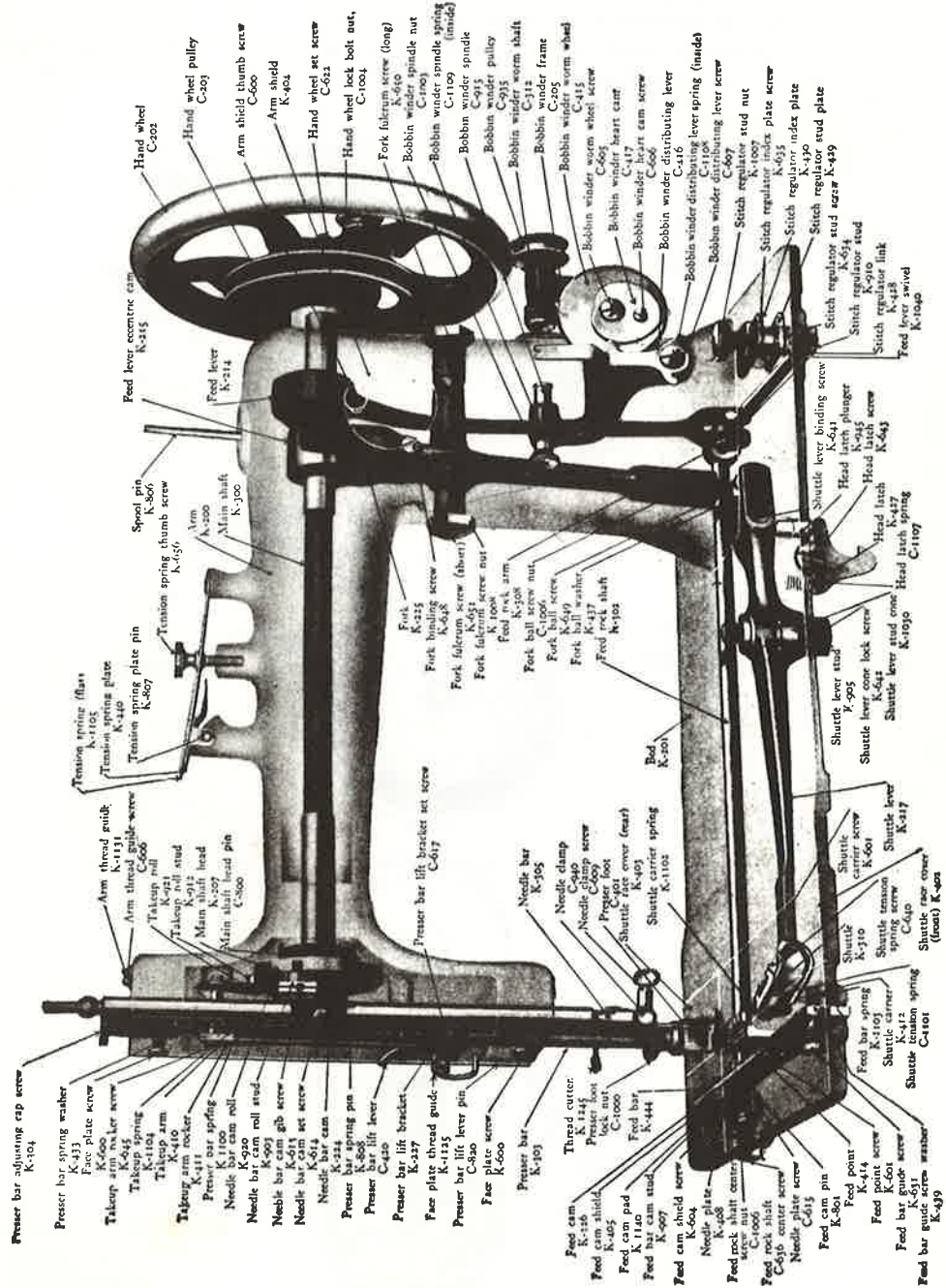

Figure 216

New Royal K, N, MO, NMO, VX, W



Hook and Race assembly for Free Westinghouse/New Home

Figure 217 shows a breakdown of the Free Westinghouse-New Home bobbin case, hook assembly.

The bobbin case holder rides on hook and is held in place by retaining ring.

Bobbin case adjustment is similiar to FR White.

To increase bobbin tension, turn adjusting screw clockwise, as needed.

To decrease bobbin tension, reverse the adjustment.

If tension spring is thread cut, replace spring.

If spring bends upward and extreme adjustment won't hold, bend down.

Check assembly for breakage or needle scars. Replace as needed.

Figure 217

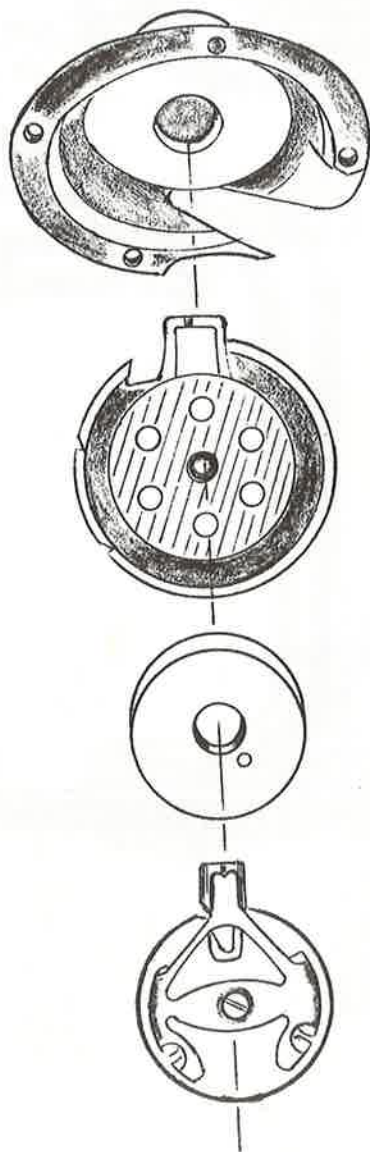

Selection of Eldredge and National machine heads.

fig. 218-222

Figure 218
Eldredge two spool. This
machine doesn't use a bob-
bin.

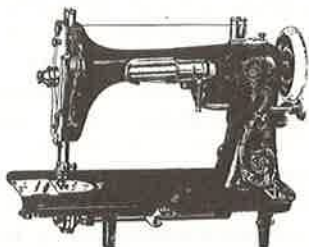

Figure 219
Eldredge B machine

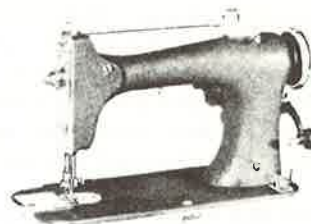

Figure 220
Eldredge A

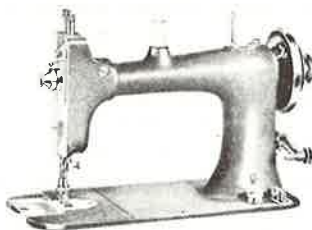

Figure 221
Rotary R40

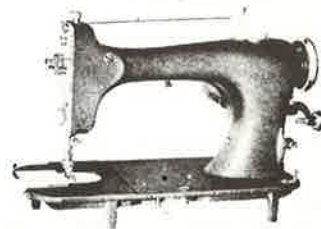
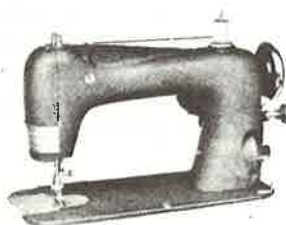

Figure 222
Streamlined machine
Montgomery Wards



Chapter Eight

Electrical Equipment.

Most sewing machines sold in the United States during the past twenty years have been electrified. With the advance of REA into the farmlands of America many housewives are able to enjoy electricity for the first time. The treadle sewing machine was either traded for an electric, or electrified.

The first electric sewing machine was marketed in the early 1920's. Manufacturers simply added a motor to a treadle head. In the late '20's, they improved the machines by adding a small balance wheel, changing sewing mechanism for quieter operation and designing the cabinet with electric operation in mind.

In 1930 the Singer Company marketed the first sewing machine totally designed for electric operation. The Singer 101 featured a built-in motor and top rotary hook. The underside of the machine was completely enclosed.

Since that time, sewing machines have been electrified in a variety of ways. White-Domestic used the friction drive pulley. National, Free and New Home utilized friction drive with motor built-in the machine. Singer featured the built-in, gear drive on top-line machines and V-belt drive on the low end models. Singer's low end machines could be used either as an electric or treadle.

After World War II, before sewing machine factories had re-tooled from wartime production, sewing machines were a rare commodity. The housewife would pay any price for a sewing machine, and often did.

Skilled repairmen bought old treadle machines, dismantled them completely, replaced or rebuilt old parts, bake painted the head, added a motor, light and control with either cabinet or portable case and sold the machine for \$150.00 and up. Thus the conversion was born.

When new machine production increased, the conversion market gradually ebbed until it's a very small part of today's market.

The late 40's ushered in the new era of imported machines. Uncle Sam was busy trying to rebuild war-torn nations, with the Marshall Plan in Europe, and the Keep Communists out of Japan. Sewing machines were a top commodity, but to circumvent high import duty, machine heads were shipped in stripped and electrified in this country. Most of the imports featured the belt drive since it was easier to attach a motor on the machine. A few contained built-in motors, but they also utilized the belt drive.

The market today is much the same. The V-belt has been created for greater efficiency. Geared machines operate quieter, and the friction drive has all but disappeared since the American domestic scene contains only the Singer Company.

White, Free-New Home Companies function as importers-distributors and National has closed its factory completely.

The Motor.

The sewing machine motor is a universal type, fractional horse power motor regulated by a rheostat type control with a range from 5 to 8 speeds, depending on the style or manufacturer.

Although motors come in a variety of sizes, shapes and attaching plates, they can be categorized into two different types.

First is the forward type and is used on all machines in which the balance wheel turns forward. This includes Singer, most long shuttles, and all imports.

Second is the reverse type. It's found on most friction drive machines, such as White, Free-New Home, etc.

The average motor contains an outer case, field, armature, two motor brushes with springs, fan, bearings, brush caps, fibre shims, lead wires, pulley and bracket for attaching motor to the sewing machine.

Servicing the forward type motor.

With the exception of Singer, most forward motors are lubricated with regular household oil. Singer utilizes a heavy viscosity lubricant with capillary action wick.

On Universal type a small oil hole is visible at each end of motor. Oil at least once a month. One drop is sufficient. On the motor requiring lubricant, fill cup every four to six months.

All motors except gear drive variety contain an adjustable bracket. Check following items.

1. Adjust belt tension. On machines with rubber belt, adjust motor bracket until belt is taut.
Over-adjustment will wear belt and shorten motor life.
When V-belt is used, adjust bracket until belt has slight play.
2. Adjust motor pulley until belt runs in straight line from balance wheel.
Use tension screwdriver and loosen set screw.
Most motors have a flat side on shaft.
Tighten set screw at this point until pulley is secure.
3. On forward motor with friction drive, move pulley until it centers on balance wheel.
As friction pulley wears, it may be moved on shaft to either side of rubber surface.
If rubber portion of pulley becomes oil soaked, replace it.
If rubber surface has been left against balance wheel for some time, it may develop a flat spot.
If this situation exists, replace the pulley.

Figure 223

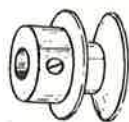
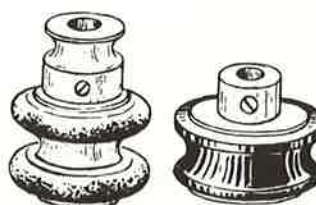

Figure 224



Dismantling the motor.

If the machine is sluggish when control is depressed, remove motor belt and turn balance wheel proper direction.

A freely turning machine indicates electrical trouble.

Depress control and observe motor.

If motor speed increases, you may assume the foot, or knee, control is functioning properly.

Motor will probably sputter, strain and show a definite lack of power.

Remove motor pulley, loosen motor bracket and remove motor from the machine.

Loosen screws in each end of motor and remove both ends of motor cover. Many models contain screws in only the front end. Motor cover is one piece, remove cover as needed.

After separating cover from motor, remove the armature.

There are two types of motor brush assembly. One contains entire assembly inside motor cover. The second and most common features a screw, cap arrangement in which motor brushes may be removed from motor without complete disassembly.

Remove cap, spring, and motor brush, or loosen wire if type one.

Clean motor with dry cloth and blow tiny particles out with a vacuum cleaner.

Inspect armature. Clean thoroughly and check for damage.

Exercise caution when cleaning commutator.

Remove carbon from cracks and sand surface with a smooth, non-metallic abrasive.

Caution: Never use emery cloth, file or anything metallic.

Check motor bearings and clean as required.

Oil hole should be opened to insure regular lubrication.

Inspect field for loose lead wires, or if motor block is affixed to motor, check both connections.

Motor brushes are carbon and wear after years of hard use.

When brush is badly worn or chipped at contact point (bevelled end) replace it, or them as the case may be.

Over oiling a sewing machine motor causes as many problems as not oiling it at all.

If motor sparks when operator starts machine, commutator is dirty, or motor brush is rough or saturated with oil.

If brush is oil soaked, it may be dried one of two different ways.

Either place in hot sun (slow process), or burn out excess oil with open flame. Hold brush at holder end with pair of needle nose pliers.

Light a match or other small flame and hold under brush.

The brush will catch fire and burn away excess oil.

Figure 225

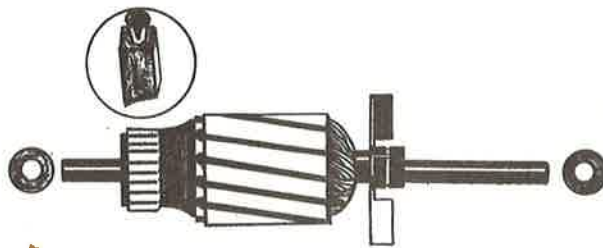

Re-assembly.

Replace armature in cover, commutator end first.

Oil holes in cover always point upward. Lubrication holder type downward.

Tighten outside holder screws and turn shaft several times to insure correct installation. Shaft must turn freely.

Move shaft and check for end play.

If excessive play is present, add fibre washer (figure 225) until .030" clearance is left.

Complete motor re-assembly.

When replacing motor brush, attach spring to holder end and insert in the channel.

Longer side of bevelled contact point must be inserted in direction of motor travel.

Forward on the forward motor, and reverse on a reverse motor.

Screw brush caps in place.

Replace motor pulley, and attach motor to machine.

Line up pulley with balance wheel, replace motor belt and test.

If motor still malfunctions after complete servicing, replace it.

It's less expensive to replace a motor than to have it rewound.

Servicing the reverse type motor.

Most common reverse type motor is the White series (A, B, C, figure 227). A and B use common household oil. Type C uses lubricant.

The White motor is dismantled by removing two nuts at shaft end of motor after motor pulley has been removed.

Remove end cap, loosen two small nuts, remove protective plate, and slide the armature out.

Refer to previous text for procedure on service and cleaning.

Replace in reverse order, until step involving the end cap.

Before tightening the last pair of lock screws, plug motor into lead wire and test. If motor is sluggish, tap outer cover sharply three or four times. When motor revs up to top speed, tighten last two lock nuts.

Replace motor pulley and attach motor to machine head.

When motor is in place, position rubber motor pulley with balance wheel and tighten set screw. If pulley is worn in center, move to one side.

On older model White with tapered pulley (figure 226), loosen set screw and slide pulley along motor shaft until pulley contacts balance wheel firmly.

Tighten set screw.

Figure 226

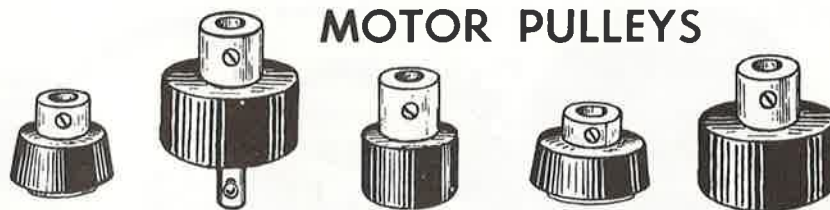

White motor grouping.

A. FR and 31 series

B. 41 and 75 series

C. 43-77 series

D. #8 series

Figure 227

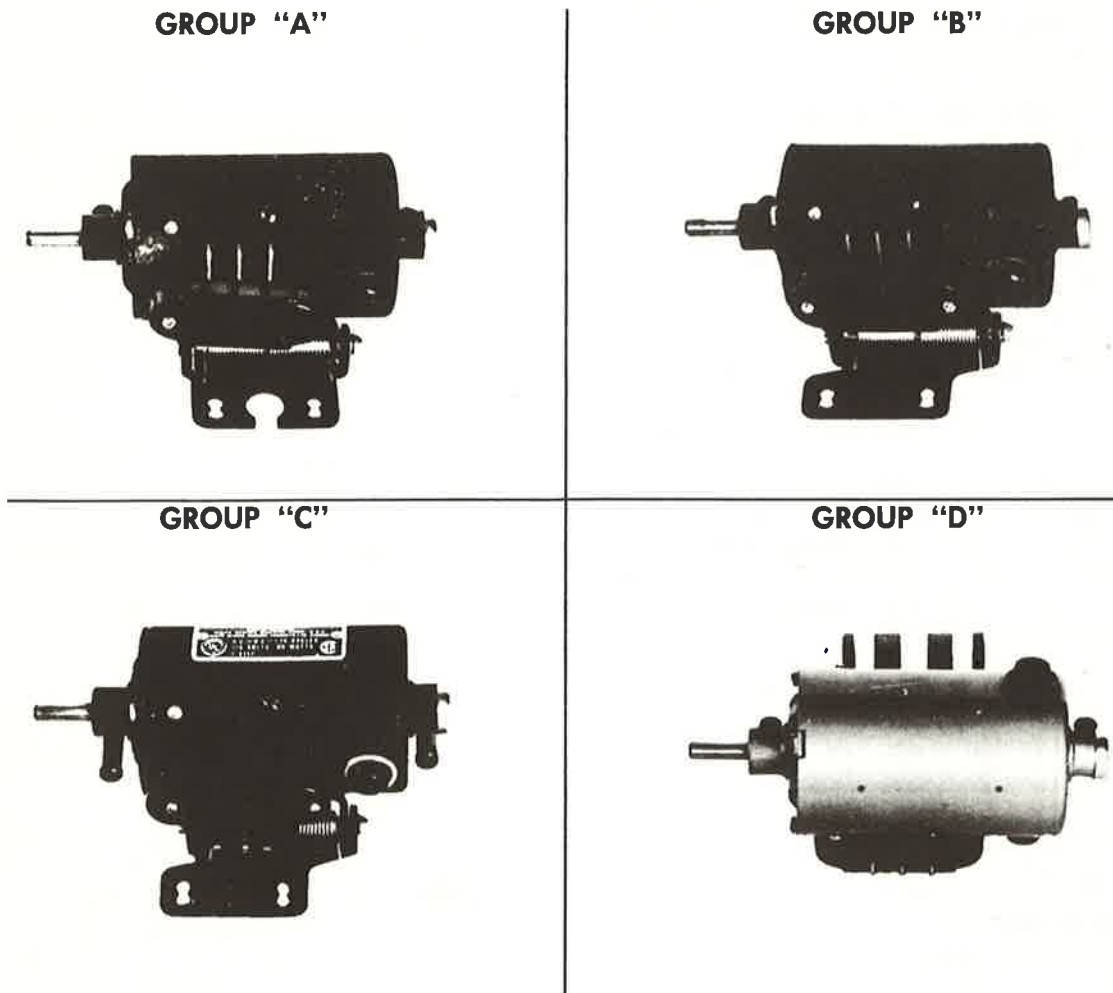

Motor pulleys, White friction drive.

Figure 228



Control and wiring assemblies.

The sewing machine control is usually a variable speed rheostat with a range of from one to eight speeds.

There are two basic types, carbon and contact point.

The carbon type features a series of tiny carbon discs set in porcelain. Two wires from motor block are attached to extreme end. A lever or button is attached to a spring and push rod assembly. When user depresses lever or button, the push rod presses against the carbon discs and releases electricity from one pole to another, and up to the motor. As the control is pressed harder, discs are jammed together allowing more electricity through until extreme allows full charge of electricity through and motor races at top speed.

The contact point type has a series of wires, different lengths, bradded into porcelain base, with a swivel arm that sweeps from one end to the other. Lead wires are attached at one end of arm and longer contact wire. When knee lever or foot button is depressed, the arm swings over and touches the contact points. Shorter wire allows a small amount of electricity through and gradually increases as control is depressed until last contact point which allows full charge through to the motor.

Control trouble is indicated if machine runs at one speed regardless of control position, or if motor runs constantly, whether control is activated or not.

There isn't a sensible way to repair a control. If control is burnt out, it must be replaced.

To replace, loosen set screw and remove bottom. This is universal since most controls are constructed alike.

Loosen lead wire at contact points and remove from control.

Replace new element in reverse order.

Caution: Always unplug wall plug before servicing electrical equipment.

1. Carbon type used by Singer.
2. Carbon type used on imported machines.
3. Contact point type.
4. Mercury contact point type, foot and knee control.

Figure 229

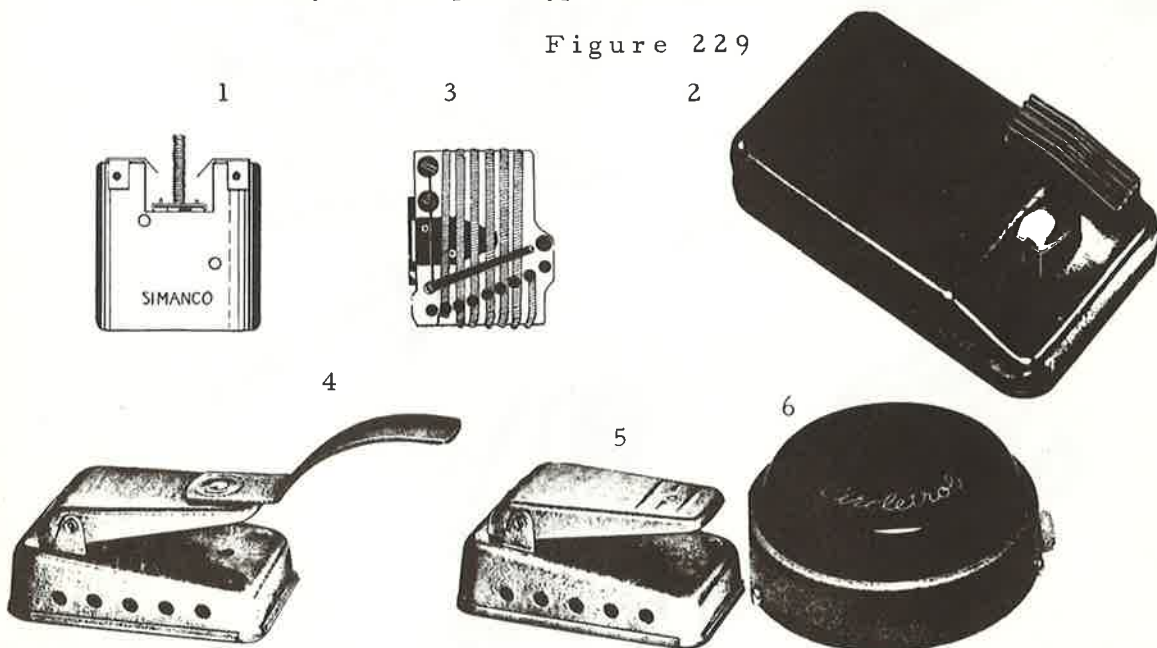

Motor block.

Universal motor block consists of two sockets, one for the light and the other for the motor. Standard male plugs are used in this simplified system. Lead wire is attached at light end of block, control wire at motor end. When lead wire is plugged into wall socket, the block is "HOT". The control wire is attached to appropriate contact points by two screws. Motor is plugged in motor end, light in light end of motor block. To check, turn light switch and light should burn. Depress control and motor should run. If not, reverse plugs.

Figure 230



Every sewing machine motor block functions in this manner, although many are very sophisticated.

The basic wiring diagram is illustrated below.

Regardless of style motor block used, wiring can be repaired from this diagram.

If a motor block isn't available, join wires as in figure 231.

Figure 231

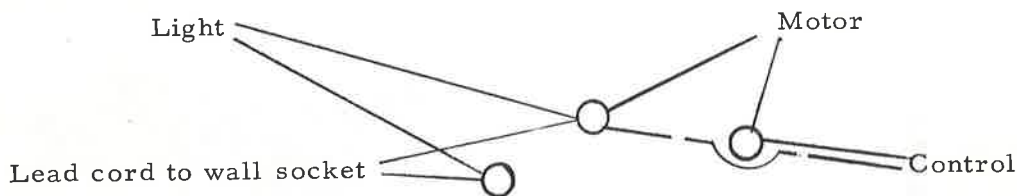

Three way hook-up.

- On three way plugs, loosen set screw and check wire at each contact.
- Remove assembly from machine and repeat checking procedure.
- Draw a diagram of location of each wire. Color if color coded.
- Turn to figure 231 and rewire as needed.

Typical three way plug and terminal assemblies.

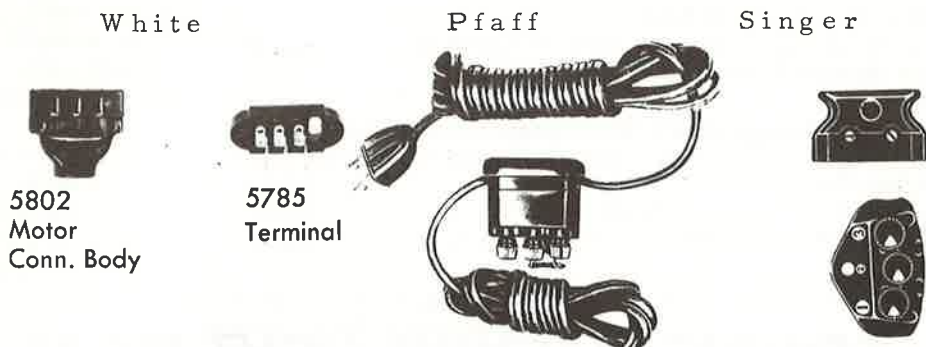

Control and motor block assemblies.

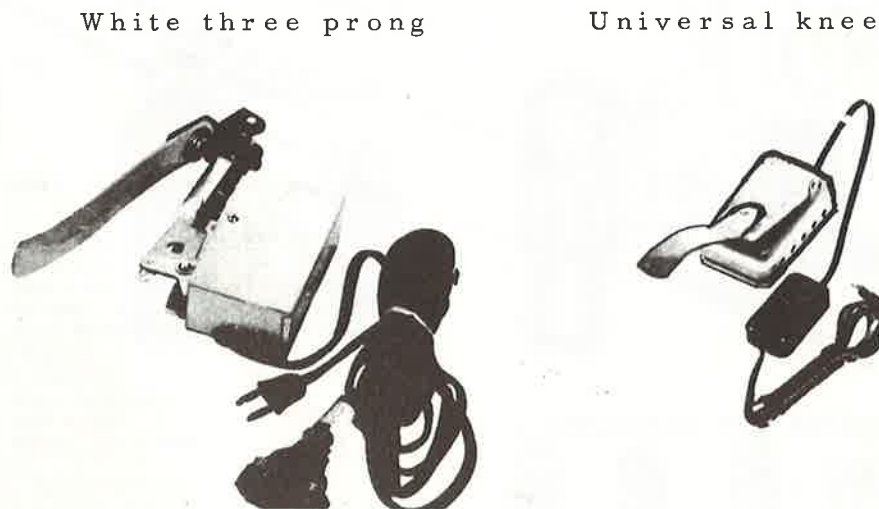

The sewlight.

Most modern sewing machines have built-in sewing lights. Some are under sewing arm and others are built-in over the needle.

A few of the low end machines still attach the sew light on rear of arm.

There is a unitized light assembly available for treadle machines.

Figure 234 shows a few of the more popular light bulbs.

1. White rotary.
2. Most imported machines.
3. Free-Westinghouse and New Home(American made).
4. Older model White and Singer.
5. Adler.
6. National, Montgomery Ward(American made).
7. Most Singer machines. Some model White's.
8. Necchi.
9. Singer.
10. Anker.

Figure 234

SEWING MACHINE LIGHT BULBS

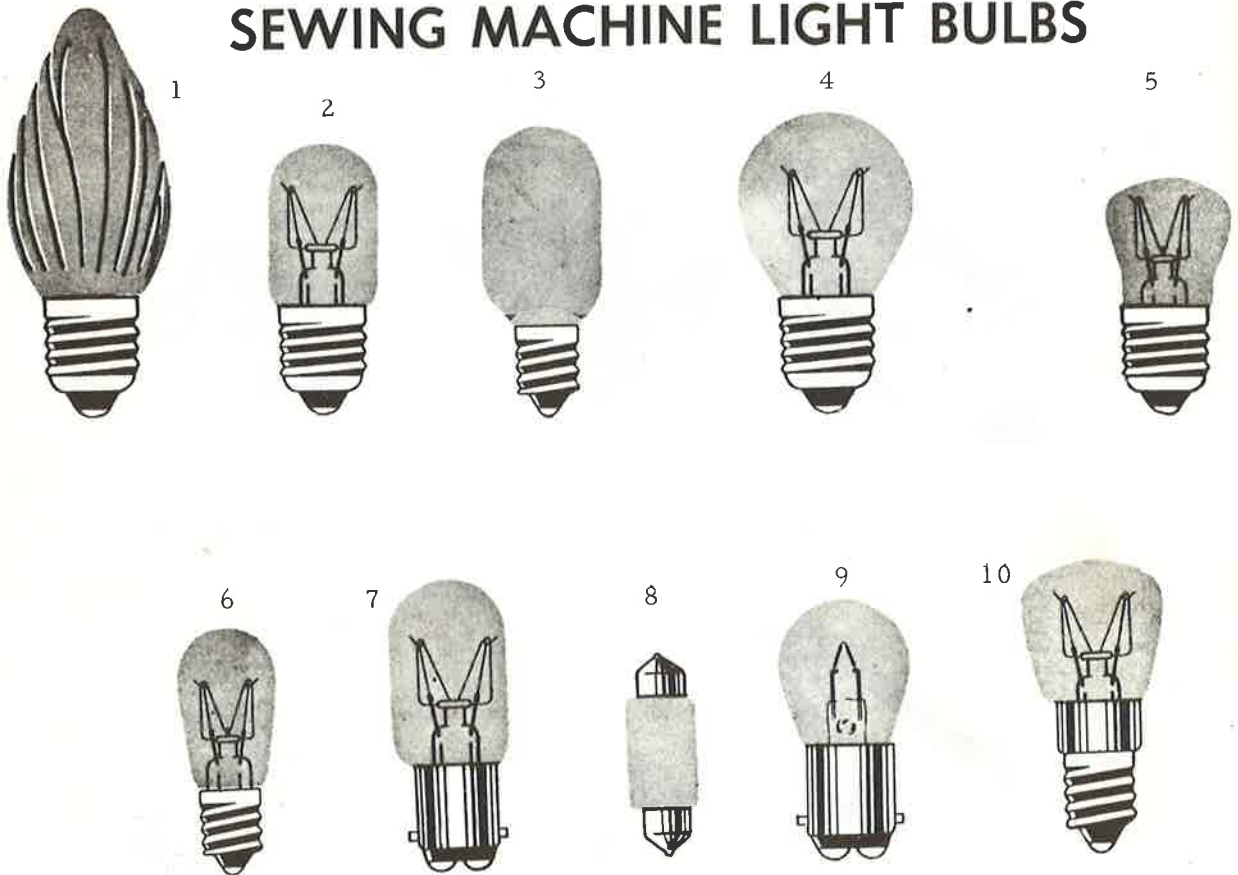

Chapter Nine

Attachments.

This chapter on attachments will consist of identification and brief description of each.

For the housewife it should enlighten and aid her in the use of "that box of parts" stuck away in machine drawer.

The serviceman may use the knowledge to further enhance his reputation. It helps to know your product when the user asks questions.

The buttonhole attachment is the most widely used attachment in the home. The automatic machine features a built-in attachment and the manual zig zag can be adjusted to make a buttonhole, therefore the attachment is for use on a straight stitch.

Greist is the frontrunner in the attachment field and most sewing machine distributors use Greist attachments.

The attachment illustrated below is for use on Singer and imported machines.

Different models are listed because manufacturers use different methods for attaching the buttonholer.

Refer to introduction and how to identify your machine for correct type for your machine.

Figure 235

GREIST BUTTONHOLE ATTACHMENTS

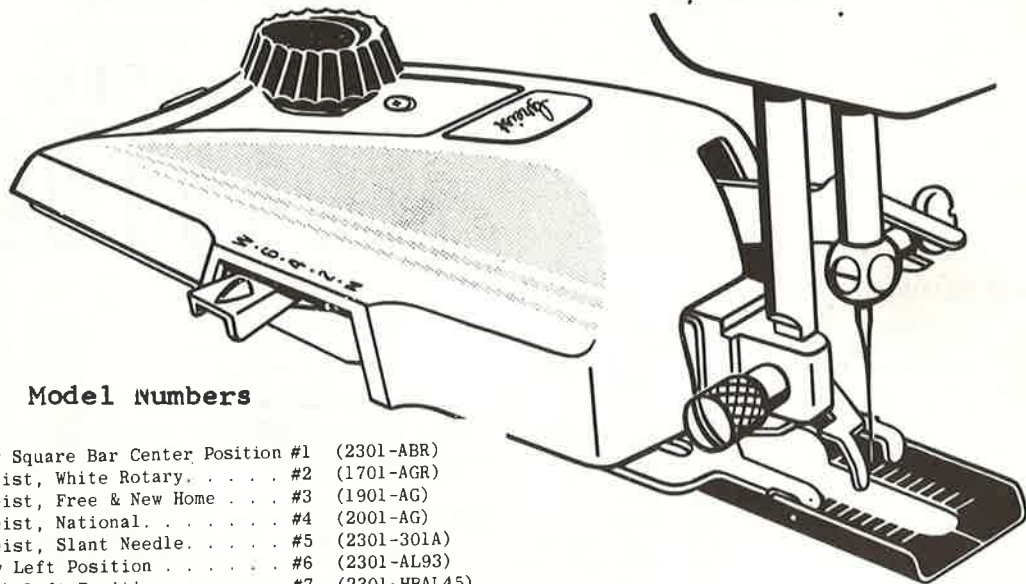

Model Numbers

Low Square Bar Center Position #1	(2301-ABR)
Greist, White Rotary #2	(1701-AGR)
Greist, Free & New Home #3	(1901-AG)
Greist, National #4	(2001-AG)
Greist, Slant Needle #5	(2301-301A)
Low Left Position #6	(2301-AL93)
High Left Position #7	(2301-HBAL45)
Greist, Pfaff (excluding model #139 & 239) #8	(2601-APF-60G)
Greist, Necchi, Low Center Position #9	(2401-AG)
High Bar, Center Position (includes Pfaff Model #139 & 239) #10	(2301-HBA)

- Templates for Buttonholer



5



Parts breakdown for Greist buttonhole attachment. (fig. 236)

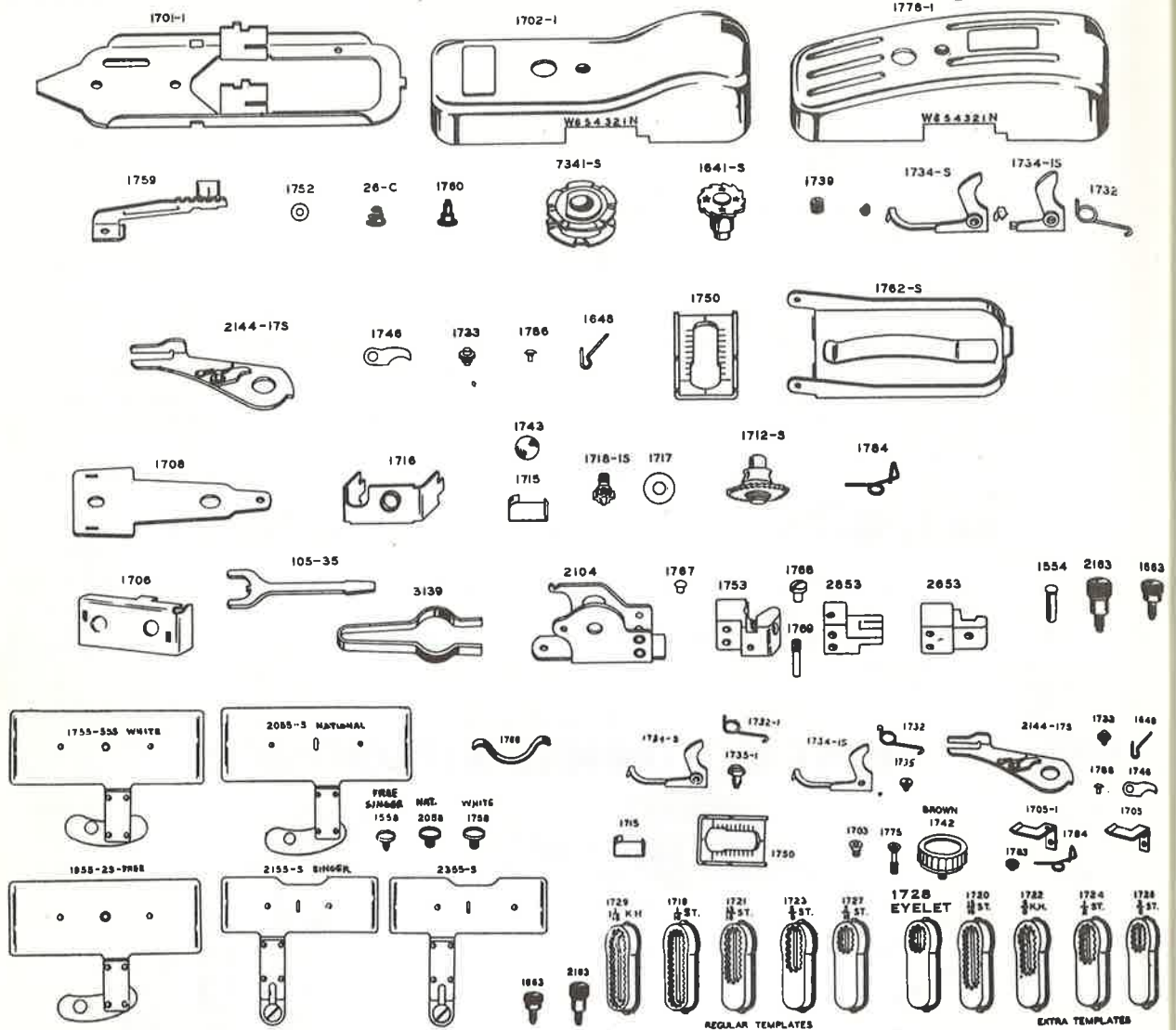

GREIST BUTTONHOLE PARTS

* ILLUSTRATED

26c	Slide Spring	1718-1s	Pinion Washer	* 1750	Cloth clamp	* 1955-2s	Feed cover plate Free ..
105-35	Wrench	Templates		1751	Feed blade	1979-b	Free knob, blue
1510	Cam roller stud	* 1719	1 1/16" straight	1752	Slide washer	1979-a	New Home knob, red ..
1511	Cam roller	* 1720	15/16" "	1753	Adapter for White	2001-1	Base for National
* 1554	Adapter rivet	* 1721	13/16" "	* 1755-5s	Cover plate, White	2004	Cam support, National ..
* 1558	Cover plate sc. Free, Sgr.	* 1722	5/8" Keyhole	* 1758	Cover plate screw	2053-1	National adapter
1641-s	Cam shaft sub assby	* 1723	5/8" Straight	1759	Slide adjuster	2054	National adapter rivet ..
* 1648	Pawl spr. for fork arm ..	* 1724	1/2" "	1760	Slide stud	* 2055-s	Cover plate, National ..
1660	Friction spring washer ..	* 1726	3/8" "	1762-s	Retainer	* 2058	Cover plate sc. " ..
* 1663	Slotted clamping screw ..	* 1727	5/16" "	1764	Rivet-retainer & name pl.	2071	Greist name plate, gm.
1701-1	Base except National ..	* 1728	Eyelet "	1765	Retainer hinge	2072	" " " blue ..
* 1702-1	Cover for Singer	* 1729	1 1/16" Keyhole	* 1766	Retainer hinge spring ..	2104	Cam support except Nat
1703	Cover screw short	* 1732	Finger Spring, O.S.	1767	Cam support rivet	* 2144-17	Fork arm
* 1705	Pawl, O.S.	* 1732-1	Finger spring, N.S.	1768	Adapter clamp screw	* 2144-17s	Fork arm
* 1705-1	Pawl, N.S.	* 1733	Pawl stud on fork arm ..	1769	Adapter stop pin	* 2155-s	Cover plate, Singer 66 ..
1706	Cover bridge	* 1734-s	Finger, O.S.	1774	Knob retaining spring ..	* 2163	Slotted clamping screw ..
1707	Cam roller stud	* 1734-1s	Finger, N.S.	* 1775	Cover screw, long	* 2355s	Cover plate, Sgr. 15-30 ..
1708	Driving lever	* 1735	Finger screw, O.S.	1779	Knob for White	2653	Adapter for Singer
1709	Lever bushing	* 1735-1	Finger screw, N.S.	* 1783	Ratchet pawl rivet	3005-1	Cam friction washer ..
1712-s	Pinion ratchet	1739	Cam set screw	* 1784	Pawl spring	3139	Wrench for National ..
* 1715	Ratchet brake spring ...	* 1742	Knob- Singer, National ..	* 1786	Rivet for pawl spring ...	3539	Fastening Bar-Free ...
1716	Hanger	1743	Ratchet brake roll	1902	Cover for Free	3575	Presser bar nut-Free ...
1717	Pinion washer	* 1746	Pawl on fork arm			7341-s	Cam

The Famous or Model C Buttonhole attachment.

The model C works on the same principle except each adjustment must be made manually.

The depth of stitch and cutting space settings are made by hand and care must be exercised to insure uniformity.

The model C is also made for industrial use. It's a special heavy duty model, however the adjustments are made in the same manner.

To service the model C, put a drop of oil in all oil holes.

Figure 237

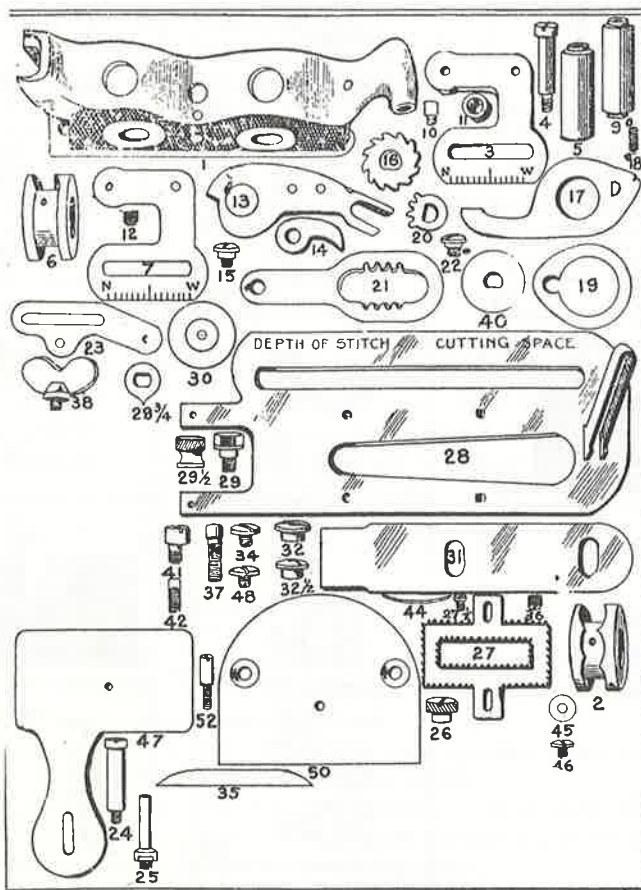

BUTTONHOLE WORKER MODEL "C"

No.	Part Name
0	Dust Cap
1	Case
2	Oscillating Cam
3	Oscillating Cam Lever
4	Oscillating and Switch Cam Lever Studs, each
5	Oscillating Cam Shaft
6	Switch Cam
7	Switch Cam Lever
8	Same as No. 4
9	Switch Cam Shaft
10	Cam Roll Stud
11	Cam Roll for 2 or 6
12	Cam Set Screw
13	Drive Lever
14	Pawl
15	Pawl Screw
16	Ratchet
17	Clutch Lever
18	Clutch Spring
19	Clutch Ring
20	Feed Gear
21	Feed Rack
22	Feed Rack Screw
23	Feed Lever
24	Feed Lever Stud
25	Adjusting Stud
26	Adjusting Stud Nut
27	Cloth Clamp
27 1/2	Cloth Clamp Screw
28	Bottom Slide
29	Adjusting Swivel Block and Stud
29 1/2	Adjusting Swivel Block Nut
29 3/4	Adjusting Swivel Block Pointer
30	Retaining Washer
31	Retaining Plate
32	Retaining Plate Rear Nut
32 1/2	Retaining Plate Centre Nut
34	Screw to hold No. 16 and No. 30
35	Cam Friction Spring
36	Cam Friction Spring Set Screw
37	Presser Bar Set Screws, each
38	Winged Screw for end of Shaft No. 9
40	Clutch Disc
41	Stitch Regulating Screw
42	Set Screw for No. 41
44	Pawl Spring
45	Washer for holding 44
46	Screw for holding 44
47	Feed Cover
48	Feed Cover Screw, flat head, for 47
50	Special Throat Plate
52	Needle Set Screw
53	Singer Presser Bar Screw

Feed Cover 47 to go over throat plate of sewing machine.

Special throat plates, No. 50, are placed over original throat plate.

Order parts by number. Always specify make and style of machine and whether attachment is Model "C" or Model "D", as some parts vary greatly for different machines.

er plate Free.
 s, blue.....
 ne knob, red..
 National
 ort, National
 adapter.....
 adapter rivet.
 ate, National.
 ate sc. "
 ame plate, gm.
 " blue
 ort except Nat
 ..
 ate, Singer 66
 lamping screw
 ate, Sgr. 15-30
 for Singer....
 ion washer..
 or National..
 Bar-Free...
 or nut-Free..

HIGH SHANK:

Left Sewing Stitch

Center Sewing Stitch

LOW SHANK:

Left Sewing Stitch

Center Sewing Stitch

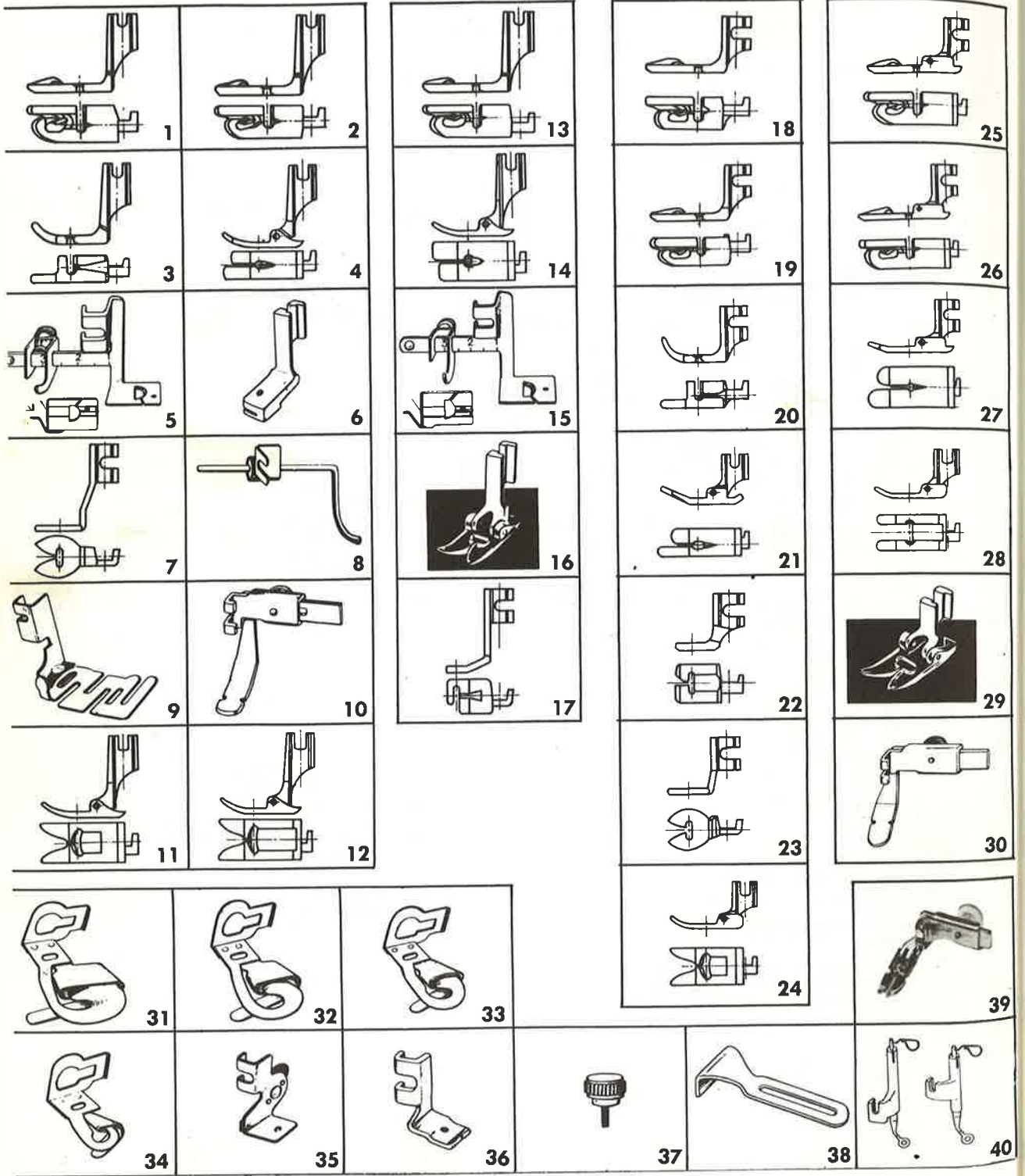

General attachments.

High or low shank referred to on page 194 indicates manner they attach to machine.

Most straight stitch machines are low shank.

Japanese made zig zag and automatic machines are generally high shank. European zig zag and automatic machines are generally low shank.

High shank.

- 1, 2 and 13. Narrow hemmer for use on shirts, handkerchiefs, etc.
3. Slotted foot for sewing over cord.
- 4, 14. Straight sewing foot for zig zag sewing machine.
- 5, 15. Buttonhole feet with adjustment guide for manual zig zag.
6. Shirring foot.
7. Button sew foot.
8. Shirring guide.
9. Rick rack guide.
10. Double zipper foot, adjustable for sewing both sides of zipper.
- 11, 12. Cording feet for left needle position zig zag.
16. Hinged sewing foot for zig zag machine.
17. Cording foot for manual zig zag (3 needle position).

Low shank.

- 18, 19, 25 and 26. Narrow hemmers.
20. Slotted cord foot, left needle zig zag.
- 21, 27. Straight sew feet for zig zag machine.
- 22, 28. Grooved feet for braid or cord.
29. Hinged sewing foot for zig zag machine.
23. Button sew foot.
30. Double zipper foot.
24. Hinged groove foot.

Straight sewing machine.

35. Attachment holder for hemmer series.
- 31, 34. Hemmers of different widths, used with holder (35).
36. Shirring foot.
- 37, 38. Straight sew guide. Screw fits in guide slot and into machine.
39. Double zipper foot.
40. Automatic darning. Remove presser foot and slip attachment in place on bar with hinge loop over needle clamp.
Lower presser bar.
Lower end holds cloth as needle enters cloth, releases on upstroke so operator can move material for darning and mending.
a. May also be used as an embroidery attachment.

wing Stitch

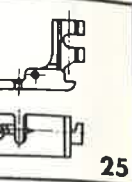

25

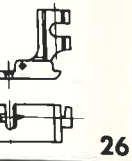

26

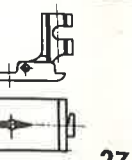

27

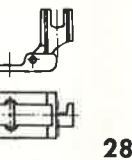

28



29

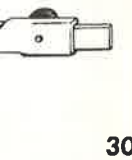

30



39



40

Chapter Ten

The Singer Model 201

The Singer 201 was marketed by Singer from the middle 1930's, to the 1950 era. It is one of the finest machines ever manufactured by the maker of countless good sewing machines.

Figure 239

Head only, Singer Model 201. You will note the gear boxes in the lower sewing mechanism, which indicates the machine is a fully rotary mechanism.

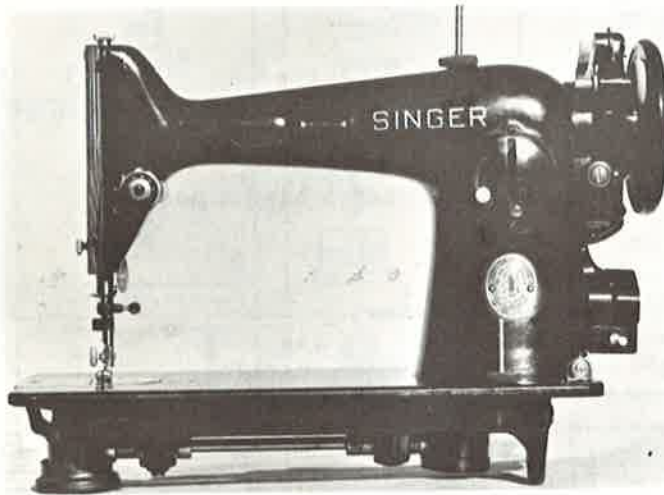

Many repair procedures that apply to the Model 201 have been covered in Chapter 2, covering the 15-91, and Chapter 3, covering the 66-18. The upper threading is similar on all Singer machines. Top threading on 201 is no exception.

If the machine skips stitches, check needle placement.

1. The needle is inserted in place on the needle bar, with the flat side out, away from the arm, and the thread is threaded the same way.
2. The same threading arrangement is used on the 301, and 400 series.
3. Inspect the thread check spring for tension. If the spring appears weak, loosen the tension assembly and adjust as needed.
4. Open slide plate and inspect bobbin-hook assembly. When the bobbin is properly threaded, the thread comes off clockwise, then back toward you, through the tension spring. See Figure 240.
5. Clean the area thoroughly. Remove the spring and clean out lint.

Figure 240

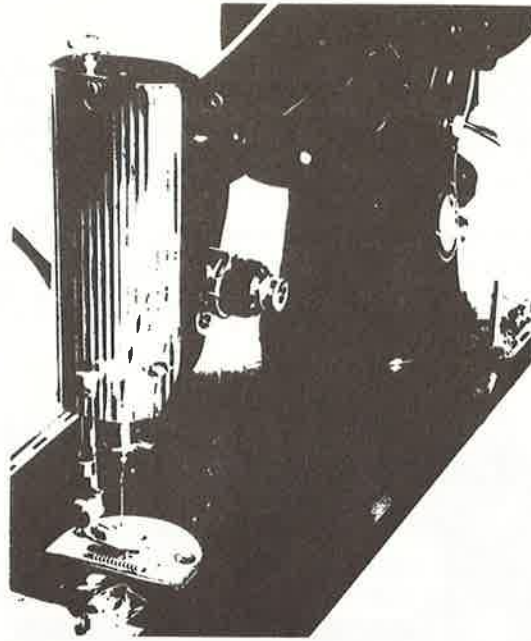

6. Inspect hook for burred or broken point. If the hook is broken, replace it. This part will most easily be purchased from Singer.
7. If the machine appears to be out of time, remove the upper face plate, then turn to Chapter 3. The Model 201 also has a link take-up arm, and may be serviced from instructions on page 58.

Tension Adjustment.

1. If the machine tension is improperly set, allowing the upper thread to loop on underside of material, check upper tension first. The tension dial is calibrated from 0 to 1. Gradually increase upper tension by turning dial clockwise. Adjust as needed.
2. If the adjustment fails to rectify the situation, slide plate open, and using a small screwdriver, turn small tension screw counterclockwise, as needed.
3. If the opposite is true, i. e. the lower thread is being drawn to top-side of the material, reverse procedure one and two.

Feed Adjustment.

1. If the material is being fed erratically, adjust the presser bar adjusting screw on the upper arm. Adjust up, or down as needed.

2. If the adjustment fails to correct, loosen needle plate screws, and remove the needle plate.
3. Tilt machine head back and view the feed dog, and position of attachment to the feed bar. Loosen set screw and raise feed dog slightly. Proper position of feed dog is $1/32$ " above needle plate, at highest point of throw. Replace the needle plate and test sew.
4. If this adjustment also fails to correct the situation, check the feed dog for excessive wear. If the teeth appear rounded, instead of a sharp-edged part, capable of gripping the material, replace it.

Lubrication.

The Model 201 is a relatively trouble-free sewing machine. However, proper lubrication is a must.

1. To lubricate the built-in motor, remove grease caps and fill with a motor lubricant, or white vasoline, if lubricant is not available. It is imperative to use lubricant, and never OIL the motor.
2. The 201 has a gear-driven motor mechanism. The gears should also be lubricated with lubricant.
3. The lower gear boxes should also be greased with lubricant. Never, use oil in the gear box area. Other sections of the machine should be lubricated with a light, free-flowing oil. Most major oil companies, as well as sewing machine firms can supply the lubricant.
4. If you're in doubt about what part to oil, tilt the machine head back and slowly turn the balance wheel, by hand, toward you. Wherever the machine moves, or any friction exists, oil it. Remove the face plate on the upper head, and repeat the procedure.
5. It's especially essential to oil the hook and bobbin case assembly. If you sew very often, do so every time you stop sewing. This gives the oil a chance to lubricate the assembly. Excess oil dries before it gets to material.
6. Oiling the upper portion of the machine head is simple. Merely oil each hole along the top of the arm, and the bobbin winder unit.
7. Clean machine head before oiling. Removing all excess lint and dust before lubricating will prevent particles from getting in parts and causing excess wear.

Singer 221

The Singer featherweight portable, Model 221 sewing machine, is one of the easier machines to adjust. The machine was originally built by the Standard Sewing Machine Company, as a Sewhandy. When Singer bought Standard, they improved the machine and came out with their own version of a very fine machine.

Figure 241

Singer Model 221, Featherweight portable sewing machine.

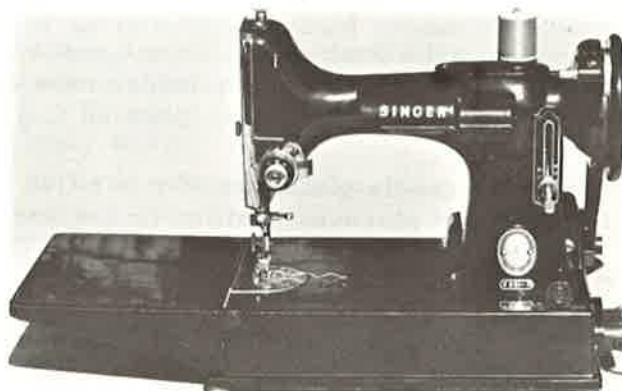

Tension.

Singer 221 tension is almost identical to the 201. To adjust the upper tension, follow the same procedure.

1. If the upper tension is too loose, and thread goes to underside of the material, turn tension dial clockwise as needed. If this doesn't do the job, remove bobbin case, figure 242, and adjust the tension screw, counterclockwise, as needed.
2. If the upper tension is too tight, and thread comes to upperside of the material, reverse the procedure, and turn tension dial counterclockwise, as needed. If this fails to correct the situation, remove bobbin case and adjust screw clockwise, as needed. Replace the bobbin case and test sew.

Figure 242



Figure 243



One troublesome tendency of the Model 221, is locking up. Any small piece of thread or line, in the bobbin case-hook assembly, will result in a thread-locked sewing machine.

1. To adjust, remove screws and lift off the needle plate.
2. Remove presser foot, and bobbin case.
3. Loosen screw in figure 243, and pull shield away from position.
4. Remove bobbin case holder(part with position finger) and clean the area. Lint, or thread, will generally be found in the track of hook component.
5. To replace, reverse the procedure, but use caution in replacing the small screw. Replace the remaining bobbin case-hook components and position bobbin case holder, with position finger pointing up.
6. When replacing the needle plate, observe position finger, and slot, in needle plate. Move slot over position finger and slide plate down in place.
7. Replace needle plate screws. Don't tighten completely.
8. Check bobbin case-hook assembly. Turn balance wheel toward you and hold bobbin case assembly in left hand. If there is no binding, resume tightening needle plate screws, replace presser foot, and test sew.
9. If the machine still binds, repeat procedure 1 through 5, until the area is clean.

Figure 244

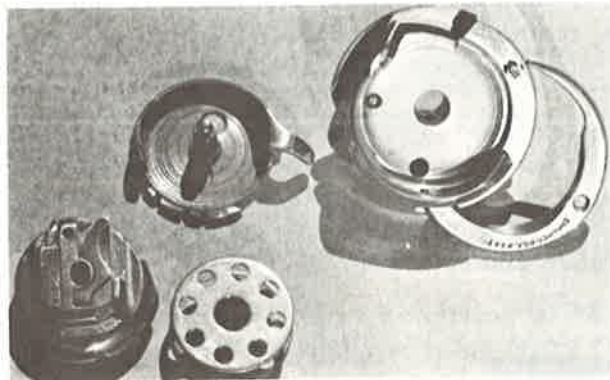

Side
Screw
Clamping

Singer
White
Brother
Morse
Atlas
Kenmore
Domestic
Free Westing
and most all
straight stitd
sewing mach

Sw Bar — Le
ig Zag and A

Although Sincere's repair book is written for user as well as repairman, there are instances where one repair tip might not work for the other.

The serviceman wants to make money, the user, save money. This chapter will point out the difference.

Figure 239 illustrates one method of identifying a sewing machine. Once the user has made identification, she should record it and keep on file for use when ordering parts or attachments.



The novice repairman should keep it with him on all repair calls, until he becomes adept in the sewing machine trade.

Most machines are name brands, but many are manufactured and sold under contract names. A contract name is a private label made for a specific company or trading area. A few examples would be, Wards Signature, Sears Kenmore, Western Auto's Wizard, Aldens and Macys.

When the type, or manufacturer has been established, turn to proper chapter in the book and proceed with service.

Machines covered in this book should enable the average serviceman to service 85% of all sewing machines in the United States.

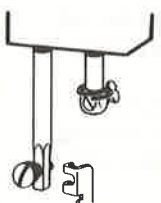
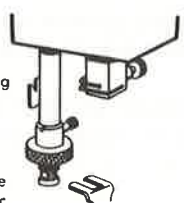
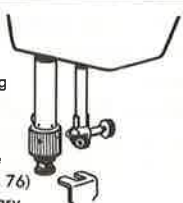
A good sewing machine repairman can make a good living in any community, large or small. He must maintain a good reputation and take pride in doing first class repair work.

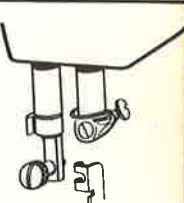
#1	#2	#3	#4	#5
 <p>Side screw clamping</p>	 <p>Top Clamping</p>	 <p>Top Clamping</p>	 <p>Top Clamping</p>	 <p>Slant Needle</p>
<p>Singer White Brother Morse Atlas Kenmore Domestic Free Westinghouse and most all imported straight stitch sewing machines</p>	<p>White Kenmore Domestic Majestic Franklin Worlds Dressmaster and all Rotary machines made by White & Domestic Sewing Machine Corp.</p>	<p>Kenmore (49, 71, 76) Free Rotary Free-Westinghouse New Home (Rotary) Stratford Most all machines made by Free & New Home Sewing Machine Company</p>	<p>Eldredge National Montgomery Ward All machines made by National Sewing Machine Company</p>	<p>Singer only.</p>

Illustrations #1 to #5--for STRAIGHT STITCH SEWING MACHINES.

NOTE: Not made for long shuttle machines.

Illustrations #6 to #10--for ZIG ZAG SEWING MACHINES.

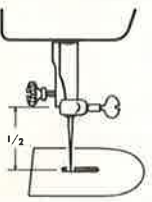
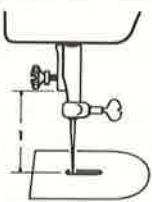
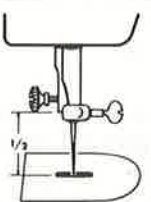
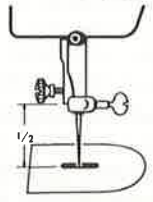
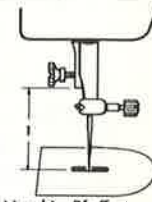
#6	#7	#8	#9	#10
 <p>Low Bar — Left Needle Position Zig Zag and Automatic Machines</p>	 <p>High Bar — Left Needle Position Zig Zag and Automatic Machines</p>	 <p>All Pfaff Sewing Machines except models 139 and 239</p>	 <p>All Necchi Straight Stitch and all Low Center Needle Position Zig Zag and Automatic Machines.</p>	 <p>All Necchi, Pfaff (Models 139 and 239) and High Bar Center Needle Position Zig Zag and Automatic Machines.</p>

The average user will probably be surprised when she reads the repair schedule and sees the margin of profit. She must remember that the repair man is in business and has overhead (cost of operating his business) to consider. He must pay the light bill, rent, telephone bill, car expense and, maintain a complete parts stock, to give you, the consumer, first class service.

This repair book will not replace the repairman, it isn't meant to, but it will enable the user to perform minor adjustments when they arise.

Procedure for User cleaning and oiling machine.

Most sewing machines set in a portable case or cabinet, on two hinges that fit into slots on machine head.

To remove head, loosen set screws, disconnect any wiring at motor block. Most machines have release plugs for quick head detachment.

Place machine head on work bench.

Remove motor belt, bobbin winder rubber and the needle.

Since carbon tet. is found in most households, we'll suggest using it for cleaning the machine. Pour some into a small oil can and squirt liberally into every oil hole on the machine.

Turn balance wheel while pouring cleaner into all oil holes.

Place machine head on its back and repeat procedure on lower machine. Continue turning balance wheel until machine is completely clean.

As the cleaner penetrates, old oil crust and dirt will fall to the bench.

When cleaner comes out clean, the machine is clean. Wipe entire machine with a clean, soft cloth.

Oil entire machine thoroughly.

To prolong the life of your sewing machine, always use a good grade of light, free flowing oil. Good maintenance will save average user considerable money over a period of years.

After machine is clean, replace the head in cabinet or portable case.

Hook wiring properly, replace new bobbin winder ring, needle and motor belt (if needed) and adjust.

1. It can't be repeated enough, lay out parts in order of removal, or draw a diagram, but the key to good service work is regulation.
2. Always remove electric cord before cleaning, and replace it when service is completed.
Never attempt service on electrical components without removing the lead cord.
3. For specific adjustment, refer to chapter covering your machine.
4. Troubleshooting guide at end of this chapter covers general adjustment procedures.

The successful repairman must establish a reputation for honesty. Don't gouge the customer. The days of "get all the law allows", are past. Arrive at an equitable price and keep it.

In a recent survey our research revealed prices in all ranges. Many too high for service rendered, and many too low.

From this survey we've established a fair and average list of services. Use this guide as guideline since service situations vary from place to place.

Troubleshooting:

Machine skips stitches.

- | | |
|--|--|
| A. Needle improperly inserted. | A. Flat side faces arm on most of straight machines. Exception is Singer 15-88/91. Machines with transverse hook face toward back. |
| B. Bent needle. | B. Replace needle. Check chart. |
| C. Incorrect needle. | C. Replace with proper needle. |
| D. Shuttle point broken. | D. Replace the shuttle. |
| E. Needle stop screw broken. | E. Replace screw in needle bar. |
| F. Needle plate damaged. | F. Replace the plate. |
| G. Incorrect threading. | G. Re-thread machine properly. |
| H. Size of needle and thread not compatible. | H. Refer to chart in introduction. |
| I. Needle bar out of time. | I. Check proper chapter for adjustment. |
| J. Hook out of time. | J. Refer to proper chapter and text. |
| K. Check spring maladjusted. | K. Refer to proper chapter and text. |

Machine doesn't stitch properly.

- | | |
|-------------------------------------|--|
| A. Tension adjusted, stitch ragged. | A. Check threads, two different sizes being used. |
| B. Cloth punctured on underside. | B. Blunt needle. Change at once. |
| C. Stitch length erratic. | C. Improper feeding. Check feed dog height and presser bar adjustment. |
| D. Too loose a stitch. | D. Check tension adjustment. |
| E. Loops on bottom. | E. Blunt needle, change. Something amiss in lower sewing mechanism. |
| F. Stitches are frayed. | F. Check hook or bobbin case for needle strikes. Dirt or lint in hook assembly, clean as needed. |
| G. Zig zag stitch uneven. | G. Check timing and tension. |

Troubleshooting:

Machine breaks upper thread.

- | | |
|------------------------------------|---|
| A. Needle in wrong. | A. Flat side faces arm on most machines. |
| B. Upper tension too tight . | B. Adjust tension per text. |
| C. Needle plate hole scarred. | C. Smooth needle hole with emery cord.
If too severe, replace plate. |
| D. Needle bent. | D. Replace needle. |
| E. Thread hanging up on hook. | E. Check hook for burrs.
Check hook for timing. |
| F. Thread hangs up on bobbin case. | F. Replace bobbin case. |
| G. Rotten or knotty thread. | G. Use new spool of thread. |

Machine breaks lower thread.

- | | |
|---------------------------------|---|
| A. Bobbin improperly wound. | A. Rewind bobbin, check winder. If malfunctioning, refer to text for service. |
| B. Bobbin bent. | B. Replace with a new one. |
| C. Thread catching in latch. | C. Check threading of case. |
| D. Dirt or lint in bobbin case. | D. Clean and oil as needed. |
| E. Bent bobbin case. | E. Replace with new one. |

Machine breaks needles.

- | | |
|------------------------------------|---|
| A. Improper needle. | A. Refer to chart and replace. |
| B. Presser foot out of line. | B. Adjust to proper position. |
| C. Operator pulls cloth. | C. Allow machine to feed itself. |
| D. Machine out of time. | D. Refer to text and re-time. |
| E. Needle bar bent. | E. Refer to text and repair. |
| F. Small needle on heavy fabric. | F. Refer to chart in introduction for proper needle. |
| G. Needle bar out of time. | G. Refer to text and adjust. |
| H. Needle not set up against stop. | H. Loosen needle clamp and set up against screw stop. |

Machine doesn't feed.

- | | |
|--------------------------------------|---------------------------------------|
| A. Check feed dog height. | A. Should be 1/32" above plate level. |
| B. Drop feed in down position. | B. Raise drop feed. |
| C. Presser bar incorrectly adjusted. | C. Refer to text and adjust. |
| D. Presser foot loose. | D. Tighten thumb screw. |
| E. Stitch control set on 0. | E. Adjust as needed. |

Machine runs hard.

- | | |
|--|---|
| A. Dry bearing or slide block. | A. Oil machine thoroughly. |
| B. Thread in hook-race assembly. | B. Clean as needed. |
| C. If just finished adjusting a part, check to see if part is binding. | C. Loosen lock nut or screw & re-adjust properly. |
| D. Motor pulley too tight against wheel. | D. Loosen screw and re-adjust. |

Motor runs, machine doesn't.

- | | |
|----------------------------------|-------------------------------|
| A. Motor pulley not touch wheel. | A. Move pulley against wheel. |
| B. Motor belt broken. | B. Replace motor belt. |
| C. Clutch washer in backward. | C. Turn washer 180 degrees. |

Motor doesn't run.

- | | |
|---------------------------------------|--|
| A. No electric current. | A. Plug into wall socket. |
| B. Incorrectly wired. | B. Check wiring per text. |
| C. Defective lead cord. | C. Replace with new one. |
| D. Brushes not contacting commutator. | D. Refer to chapter 8. |
| E. Motor burned out. | E. Replace motor. |
| F. Control rheostat burned out. | F. Replace foot control.
If partially burned out, control will run at high speed. |

This troubleshooting guide is for general adjustment. For complete repair or service, refer to chapter covering machine in question.
To get the most out of this book, read it from cover to cover.

The End

CANTERBURY
PUBLIC LIBRARY

