

# Service Manual

## Foreword

This provisional Service Manual has been compiled in order to enable our service personnel to carry out all repairs on these machines quickly and satisfactorily. It will be superseded by the final edition when it is published.

Before you carry out any adjustments, acquaint yourself with the settings discussed in this Manual and check whether the machine is actually out of adjustment. Since, apart from a few minor details, the mechanical setup of Pfaff machines 1222, 1221, 1212 and 1211 is the same, the instructions contained in this Manual apply to all of them. Variations in the adjustment procedure which are necessitated by differences in design are discussed separately.

For checking up or adjusting a machine, it is best to follow the procedure outlined in the Manual. When re-assembling machines which have been dismantled completely, roughly adjust all parts in order to facilitate final adjustment.

When ordering spare parts, please refer to the Spare Parts Catalogue and state the following:

1. Machine class
2. Complete ten-digit
3. Part name
4. Color of finish, if part is lacquered.
5. Old or new version, if applicable.

When making electrical repairs, be sure to comply with the safety regulations in effect in your country. Since part of the electrical system of these machines must only be tested at low tension, proceed in strict compliance with the instructions given in the chapter on the "Electrical System". For this reason, all electrical repairs must be performed by an expert.

Adjustment of the machine is greatly facilitated by the following tools and gauges:

|                                 |               |
|---------------------------------|---------------|
| Needle rise gauge               | 870 136-01    |
| C-clamp for above gauge         | 870 137-00    |
| Bobbin case position slot gauge | 7.501.00-201  |
| Machine feed gauge              | 63-112 120-08 |
| Special spanner                 | 106 300-306   |
| Combination spanner, 5.5 mm     | 43-111 010-04 |
| Combination spanner, 7.0 mm     | 43-111 010-05 |
| Combination spanner, 8 mm       | 43-111 010-06 |
| Circlip pliers, ZA 21           | 07-438 000-40 |
| Circlip pliers, A 1             | 07-438 000-50 |
| Clip washer pliers, 1.9 kz      | 07-437 003-10 |
| Clip washer pliers, 2.3 kz      | 07-437 003-20 |
| Clip washer pliers, 3.2 kz      | 07-437 003-30 |
| Clip washer pliers, 4.0 kz      | 07-437 003-40 |
| Clip washer pliers, 5.0 kz      | 07-437 003-50 |
| Clip washer pliers, 6.0 kz      | 07-437 003-60 |
| Clip washer pliers, 7.0 kz      | 07-437 003-70 |

## C o n t e n t s

|   | Page |
|---|------|
| Foreword  | 1    |
| Technical Data  | 5    |
| <br><u>Stopmatic Mechanism</u>  |      |
| Operation   |      |
| 1. Adjusting the Clutch Lever   | 7    |
| 2. Setting the Roller in Relation to the Roller Clutch Pin            | 9    |
| <br><u>Zigzag Mechanism</u>   |      |
| 3. Dismantling the Automatic Mechanism                                | 10   |
| 5. Relative Adjustment of Worm Gears and of Drive Lever               | 11   |
| 6. Adjusting the Needle Position Knob                                 | 12   |
| 7. Basic Position of Eccentric Stud in Needle Bar Frame               | 13   |
| 8. Zeroing the Needle for Straight Stitching                          | 14   |
| 9. Adjusting the Needle Vibration Controlled by the Zigzag Mechanism  | 15   |
| 10. Adjusting the Needle Position                                     | 17   |
| 11. Centering the Needle Throw in the Needle Plate Slot               | 18   |
| <br><u>Buttonhole Mechanism</u>                                       |      |
| 12. Operation of Buttonhole Mechanism                                 | 20   |
| 13. Basic Position of Buttonhole Control Stop                         | 22   |
| 14. Adjusting the Relative Position of Driving Pawl and Ratchet Wheel | 23   |
| 15. Timing the Pawl Stroke  | 24   |
| 16. Final Adjustment of the Buttonhole Control Stop                   | 26   |
| 17. Timing the Buttonhole Forward-Reverse Feed                        | 28   |
| <br><u>Feed Mechanism</u>   |      |
| 18. Lateral Adjustment of Feed Dog                                    | 29   |
| 19. Setting the Feed Dog Parallel to the Needle Plate                 | 31   |
| 20. Setting the Feed Dog at the Correct Height                        | 32   |
| 21. Adjusting the Feed Eccentric Clutch Sleeve                        | 33   |
| 22. Adjusting the Feed Eccentric Endwise                              | 35   |
| 23. Adjusting the Link-Type Feed Regulator Endwise                    | 36   |
| 24. Zeroing the Feed Regulator  | 37   |
| 25. Timing the Top and Bottom Feed Strokes                            | 38   |

|   | Page |
|---|------|
| 26. Adjusting the Drop Feed Mechanism   | 40   |
| 27. Setting the Presser Bar at the Correct Height   | 41   |
| 28. Adjusting the Pressure on the Material  | 43   |
| 29. Lateral Adjustment of Feeding Foot in Relation to Sewing Foot   | 44   |
| 30. Adjusting the Feeding Foot in Sewing Direction  | 46   |
| 31. Adjusting the Feeding Foot Vertically   | 47   |
| 32. Adjusting the Vibrator  | 48   |
| 33. Timing the Buttonhole Forward-Reverse Feed  | 50   |
| <u>Sewing Mechanism</u>   |      |
| 34. Adjusting the Position of the Needle in the Needle Plate Slot   | 52   |
| 35. Basic Position of Hook Bearing  | 52   |
| 36. Timing the Sewing Hook  | 53   |
| 37. Setting the Needle Bar at the Correct Height  | 54   |
| 38. Setting the Hook-to-Needle Clearance  | 57   |
| 39. Adjusting the Bobbin Case Position Finger   | 58   |
| <u>Automatic Mechanism</u>  |      |
| 40. Operation   | 60   |
| 41. Fitting the Automatic Mechanism   | 63   |
| ..... Fixed-Ratio Automatic Mechanism   |      |
| 42. Setting the Clearance between Worm and Worm Wheel   | 65   |
| 43. Setting the Feeler Fingers Close to the Cam Stack   | 66   |
| 44. Adjusting the Needle Vibrating Controlled by the Fixed-Ratio Automatic Mechanism  | 67   |
| 45. Centering the Needle Throw in the Needle Plate Slot for Functional Stitching  | 69   |
| 46. Adjusting the Length of Forward and Backward Stitches for Hemstitching  | 70   |
| ..... Variable-Ratio Automatic Mechanism  |      |
| 47. Setting the Feeler Fingers Close to the Cam Stack   | 72   |
| 48. Zeroing the Pattern Length Wheel  | 73   |
| 49. Close Setting of Feeler Finger for Scallops   | 74   |
| <u>Electrical System</u>  |      |
| 50. Description of Electrical Equipment   | 75   |
| 51. Setting the Maximum Speed and the Speed for the Stopmatic Control   | 76   |
| 51a. Setting the Maximum Speed of Machine and Stopmatic Mechanism on Machines Equipped with Dual-Voltage-Range Motors (110 and 220 V) | 78   |
| 51b. Different Versions of Machines Equipped with Electronic Control  | 80   |
| 51c. Exchanging the Potentiometer in the Foot Control of Models 1221 and 1222   | 81   |
| 53. Adjusting the Cleated Belt Tension  | 83   |
| 54. Test Procedure and Trouble Shooting in the Electrical System  | 84   |



|  | Page |
|--|------|
| <u>Sewing Off</u>  |      |
| 54. Adjusting the Bobbin Winder  | 85   |
| 55. Operation of Needle Threader   | 86   |
| 56. Adjusting the Threader Bar Collar  | 86   |
| 57. Adjusting the Needle Threader Head   | 87   |
| 58. Tension Regulation   | 88   |
| 59. Adjusting the Bobbin Thread Tension  | 88   |
| 60. Adjusting the Needle Thread Tension  | 89   |
| 61. Adjusting the Tension Release Mechanism  | 90   |
| 62. Adjusting the Stroke of the Thread<br>Check Spring                               | 91   |
| 63. Adjusting the Length of Forward and<br>Backward Stitches for Hemstitching        | 92   |
| 64a. Setting the Household Overlock Stitch   | 92 a |
| 64. Adjusting the Length of Forward and<br>Backward Stitches for Triple-Stitch Seams | 93   |
| 65. Making a Sample Various repair jobs Swatch                                       | 94   |
| 66. Changing the motor and the carbon brushes  | 95   |
| 67. Changing the pressure spring in the<br>balance-wheel realise knob                | 99   |

Technical Data

- Pfaff 1222 free-arm sewing machine with additional top feed and combined automatic unit consisting of a fixed-ratio functional-stitch mechanism and a variable-ratio ornamental-stitch mechanism.
- Pfaff 1221 flatbed sewing machine with additional top feed and combined automatic unit consisting of a fixed-ratio functional-stitch mechanism and a variable-ratio ornamental-stitch mechanism.
- Pfaff 1212 free-arm sewing machine with fixed-ratio automatic functional-stitch mechanism.
- Pfaff 1211 flatbed sewing machine with fixed-ratio automatic functional-stitch mechanism.

Fixed-ratio automatic unit with forward-reverse feed control, reduction ratio 12:1.  
Five functional stitches which can be varied by different zig-zag settings or combined.  
Variable-ratio automatic unit with intermittent drive and stitch number regulation.  
Five ornamental stitches which can be varied by different needle position and pattern length settings or combined.  
Zigzag mechanism with needle vibration control and needle position adjustment (left, center, right).  
Stitch length and stitch width settings are combined in fixed relationship.  
Semi-automatic buttonhole unit with forward-reverse feed control.  
Feed eccentric clutch (for reverse sewing and buttonholing).  
Top and bottom feeds, 1:1 feed ratio, upper feeding foot can be disengaged.  
Electronic speed control by thyristor control.  
Master switch for electrical system.  
Stopmatic control with roller clutch for controlling needle position at end of sewing action.  
Drop feed mechanism combined with vibrator for operating the presser bar.  
Power is transmitted from the arm shaft to the hook drive shaft by a clip belt at a ratio of 1:2.  
Power is transmitted from the motor to the shaft by a cleated belt.  
Link take-up.  
Vibrating needle bar frame.  
Transverse, double-revolution rotary hook.  
Needle system 130.  
Light-metal casting.  
Weight of machines with motor, but without accessories:  
Pfaff 1222 10.20 kg (22.4 lbs)  
Pfaff 1221 9.00 kg (19.8 lbs)  
Pfaff 1212 9.50 kg (20.9 lbs)  
Pfaff 1211 8.35 kg (18.3 lbs)  
Stitch length approx. 4 mm (6 s.p.i.)  
Stitch width approx. 4.5 mm (11/64")

Clear work space: 225 x 120 mm (9" x 4 3/4")  
Bedplate dimensions: 421 x 178 mm (15 1/2" x 7")  
Baseplate dimensions on free-arm machines: 421 x 178 mm  
(15 1/2" x 7")  
Motor: Type GE 270, 220 or 110 V, 0-60 c/s, 40/80 W,  
7000 r.p.m.  $\pm$  10 %  
Type GE 271, dual-voltage-range motor for 220 or  
110 V connection, 0-60 c/s, 40/80 W,  
7000 r.p.m.  $\pm$  10 %  
Fully radio and TV suppressed.  
Suppression class: FN  
Sewing head: insulation class 2  
Motor alone: insulation class 1  
Glare-free sewing light, 15 W.  
Finish: light grey (No. 6)  
Subject to alterations in design and dimensions.

### Various Data

|   |                                 |
|---|---------------------------------|
| Needle bar rise   | 2.0 mm (.08")                   |
| Hook-to-needle clearance  | 0.1 mm (.004")                  |
| Needle bar height (top of needle eye<br>to lower edge of hook point), set<br>with machine set for widest zigzag<br>stitch and needle on left of its<br>throw. | 0.5 mm (.02")                   |
| Clearance between bobbin case po-<br>sition finger and position slot  | 0.7 mm (.027")                  |
| Feed dog height   | 0.9 mm (.035")                  |
| Foot lift   | 6.5 mm (.25")                   |
| Maximum feeding foot rise   | 1.2 mm (.05")                   |
| Final phase of feed stroke  | 0.6 - 0.7 mm<br>(.023" - .027") |
| Lowest position of darning foot<br>above needle plate level   | 0 - 0.1 mm (.004")              |
| Maximum sewing speed  | 900 - 1000 r.p.m.               |
| Maximum speed of Stopmatic mechanism  | 120 r.p.m.                      |

## STOPMATIC MECHANISM

### Operation

The Stopmatic mechanism is engaged when the presser bar lifter is at its top or bottom-most position. When this lever is operated, this motion is transmitted to clutch lever 5 via connecting rod 32 (Fig. 1). The clutch lever in turn engages and disengages a roller clutch. The machine is stopped by the Stopmatic mechanism when the take-up lever is roughly at its highest point. At this point, clutch lever 5 drops into a cutout in belt sprocket 34 and pushes against slide 33 (with pin). This slide, in turn, pushes against a roller and thus disengages the roller clutch. Micro switch 9 is switched off simultaneously.

### 1. Adjusting the Clutch Lever

#### Rule:

With the presser bar lifter up in Stopmatic position, there should be a clearance of 0.7 to 1.5 mm between slide 33 and clutch lever 5, so that when the presser bar lifter is pushed right down there is a minimum clearance of 0.1 mm. Also, lug 26 of lever 28 (Fig.1) must be in contact with micro switch 9 in both of the above positions of the presser bar lifter.

#### Check:

Remove the arm standard cover and the balance wheel. Take out the three screws 37 (Fig.2) and remove cover disc 36. Bring the presser bar lifter to the upper Stopmatic position and turn the arm shaft in sewing direction until clutch lever 5 (Fig.1a) has dropped into the cutout of upper sprocket 34. Check the clearance of 0.7 to 1.5 mm (varies on individual machines) between slide 33 and clutch lever 5. Push the presser bar lifter down as far as it will go and check the minimum clearance of 0.1 mm, too.

#### Adjustment:

Push the presser bar lifter back up to the Stopmatic position. Loosen screw 29 and press lever 28 to the left until the clearance of 0.7 to 1.5 mm is correct. Fully tighten screw 29.

Verification:

Push the presser bar lifter up beyond its Stopmatic position and watch the clearance while doing so. Push the presser bar lifter down as far as it will go and check the clearance again. During the longest stroke, there must be a safety clearance of 0.1 mm so that the micro switch is not operated.

Note:

If clutch lever 5 strikes slide 33 when the presser bar lifter is pushed up or down, the clearance must be repeatedly altered with the presser bar lifter up, until the lever no longer strikes the slide in the up or down position. It must not be possible for clutch lever 5 to snap out of the cutout in the upper sprocket when the arm shaft is turned backwards.

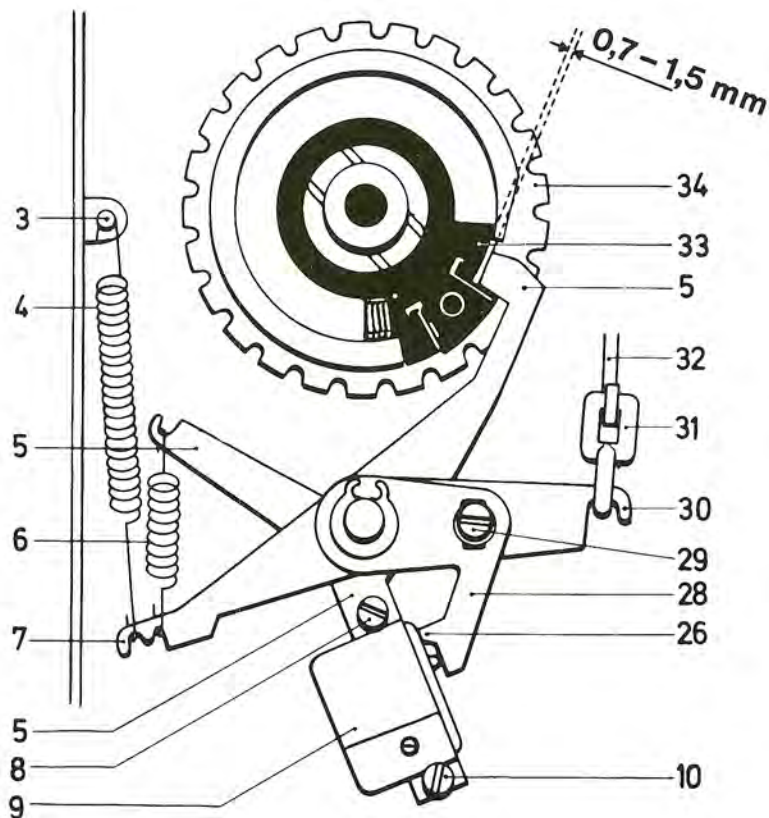

Fig. 1



## 2. Setting the Roller in Relation to the Roller Clutch Pin

### Rule:

Pin 39 on the slide (Fig. 2) should be positioned slightly to the left of the middle of roller 38.

### Check:

Lower the presser bar lifter and turn the balance wheel until roller 38 is at the top. Make a visual inspection (see Fig. 2).

Fig. 2

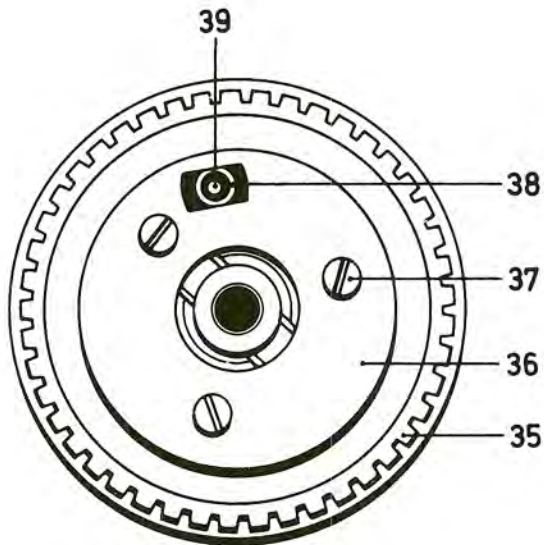

### Adjustment:

Loosen the three screws 37 and turn the complete roller clutch 35 until the above setting is correct. Then tighten the three screws 37 securely again.

### Verification:

Operate the Stopmatic mechanism several times by flicking the presser bar lifter to its top and bottom-most positions.

ZIGZAG MECHANISM

3. Dismantling the Automatic Mechanism

Note:

For all adjustments which are to be made on the zigzag and buttonhole mechanisms, the automatic mechanism must first be removed.

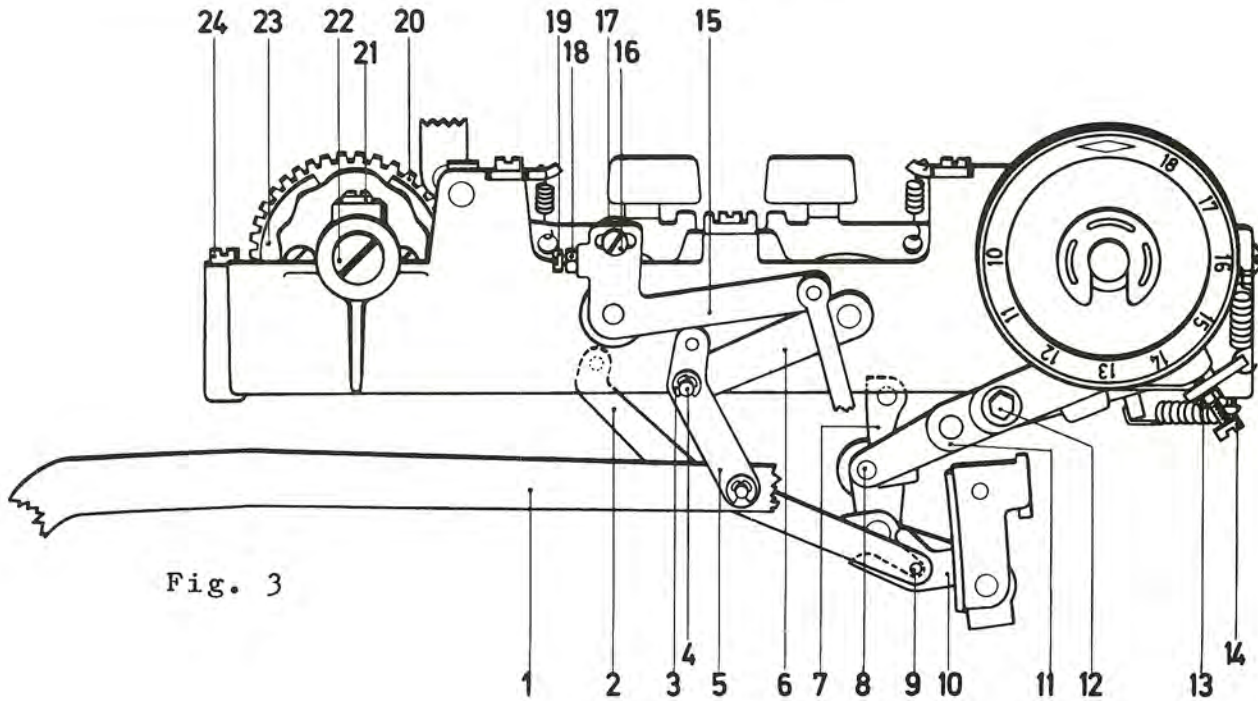

Fig. 3

Dismantling procedure for Pfaff 1222 and 1221 machines:

Remove the top cover and pull off slip washer 3 (Fig. 3). Take out screw 16 and pull off adjusting bracket 15. Take out the four screws 24 of the automatic mechanism and remove the complete mechanism.

Dismantling procedure for Pfaff 1212 and 1211 machines:

Remove the top cover, take out screw 16 and pull off adjusting bracket 15. Turn out the four screws 24 of the automatic mechanism and remove the complete mechanism.

## 5. Relative Adjustment of Worm Gears and of Drive Lever

### Rule:

Worm 3 and worm wheel 12 (Fig. 5) should have almost no play. There should be a clearance of 0.1 mm (.004") between roller 6 on drive lever 7 and arm shaft 1 (Fig. 5a) so that the roller does not contact the shaft when the lever moves back and forth. In addition, the axis of the zigzag mechanism should extend exactly at an angle of  $90^\circ$  to the arm standard.

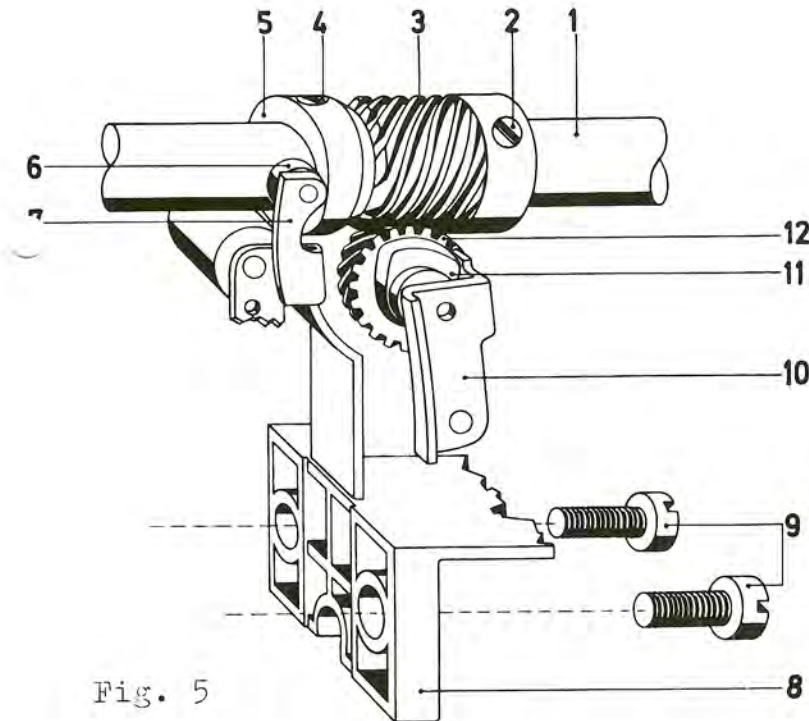

Fig. 5

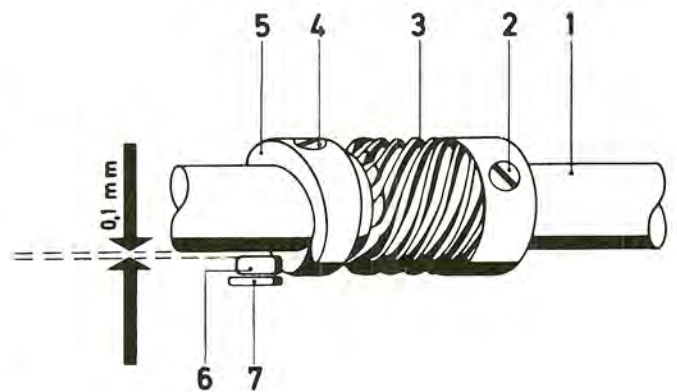

Fig. 5a

### Adjustment:

Slightly loosen both screws 9 (Fig. 5). Then adjust the position of zigzag mechanism 8 vertically and laterally until the worm and worm wheel are properly meshed and the clearance between drive lever 7 and arm shaft 1 is correct. Fully tighten both screws 9 of the zigzag mechanism.

### Verification:

Slightly rock zigzag eccentric 11 back and forth to see if worm and worm wheel are properly meshed and their teeth have practically no play. Also, the drive lever should work smoothly.



## 6. Adjusting the Needle Position Knob

### Rule:

When the needle position knob is turned to the central needle position, the symbol for this position should be exactly below the white mark on the dial, and the knob should have snapped into this position.

Fig. 6

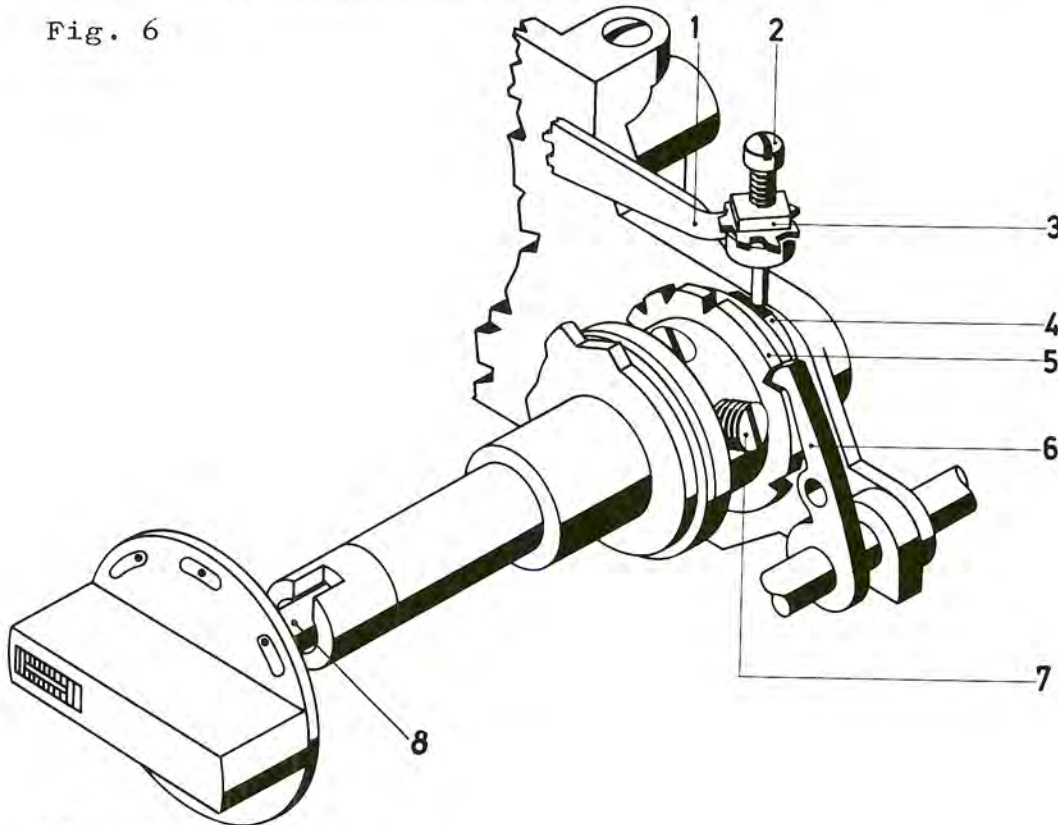

### Adjustment:

Turn the knob until screw 2 contacts the flat spot marking the central needle position on needle position cam 4 and latch 6 has snapped into the respective notch in the rim of disc 5 (Fig. 6). Loosen screw 7 on the right side of the cam hub and turn the knob until the symbol for the central needle position is exactly below the white mark on the dial. For this adjustment the knob must be pushed all the way into dial. After the adjustment, tighten screw 7 very securely.

### Verification:

Turn the knob to its three positions several times and check to see that the symbol for the central needle position is exactly below the white mark on the dial when the knob is turned to this position.

### Notice 1 :

At the second version of the needle position knob, axle 8 of the knob has a flat surface. Screw 7 must be fixed on this flat surface.

### Notice 2 :

At the third version of the knob, axle 8 has a tap hole. For fixing screw 7 it must be turned into the tap hole and then be tightened securely.

## 7. Basic Position of Eccentric Stud in Needle Bar Frame

### Rule:

In its basic position, the eccentric stud should be turned so that its lobe points upward (Fig. 7a).

Fig. 7

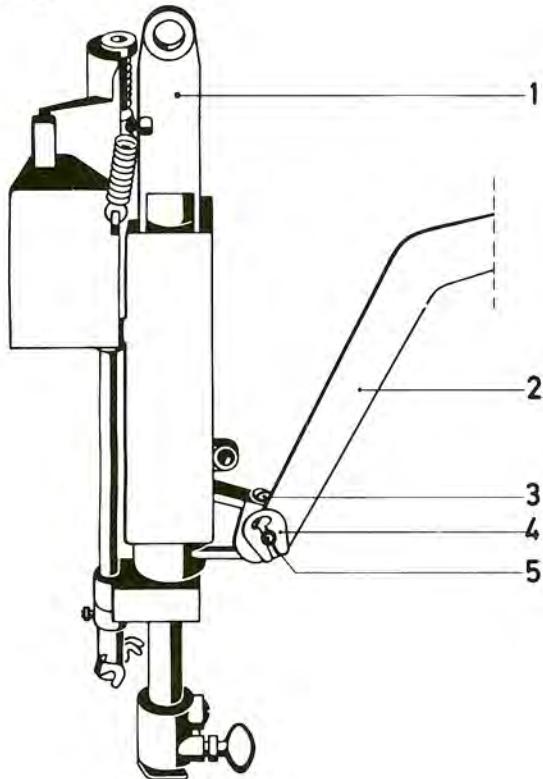
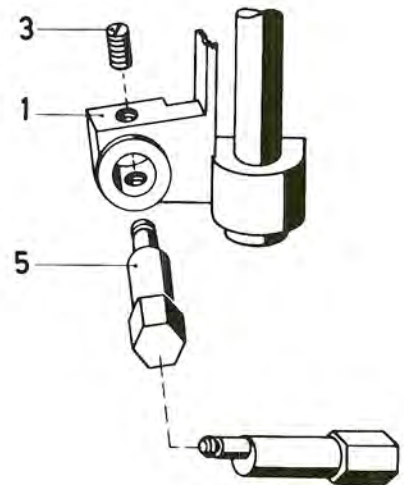

Fig. 7a



### Adjustment:

Turn the master selector dial to the widest zigzag stitch (stitch range 8). Loosen the two screws in the face cover and remove the latter.

Loosen screw 3 in needle bar frame 1 (Fig. 7). Turn eccentric stud 5 with the aid of a 5.5-mm spanner so that its lobe points upward. Then continue turning the eccentric stud until the needle clears the right and left edge of the needle plate slot with the same distance when descending on the right and left of its throw, respectively. Tighten screw 3 to fix the eccentric stud in this position, but make sure the connecting rod still has a small amount of lateral play.

### Note:

The vibrating motion of the needle bar is timed later and, hence, need not be correct at this stage.

## 8. Zeroing the Needle for Straight Stitching

### Rule:

When the master selector dial is in the 0-4 stitch range, the machine should sew a perfect straight-stitch seam.

### Check:

To check, drop the machine feed, turn the master selector dial to the 0-4 stitch range and the needle position knob to the central needle position. Raise the sewing foot and insert a new System 130 needle. Place a piece of thin cardboard on the needle plate and lower the sewing foot to hold it in place. Carefully turn the balance wheel toward you until the needle pricks the cardboard just lightly. Then turn the balance wheel backward until the needle again pricks the cardboard (Fig. 8). If the second needle puncture does not coincide exactly with the first, zero the needle position.

Fig. 8

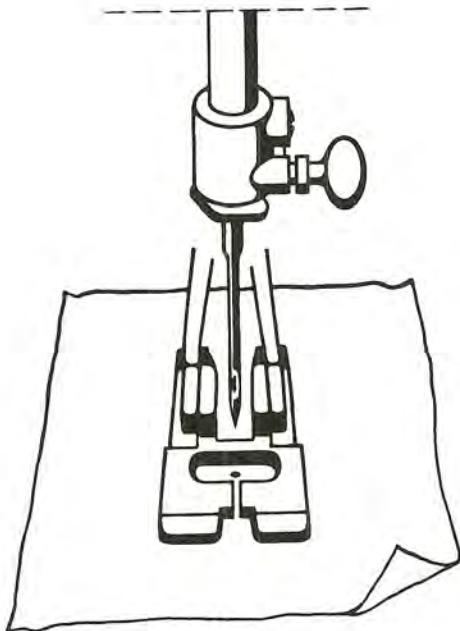
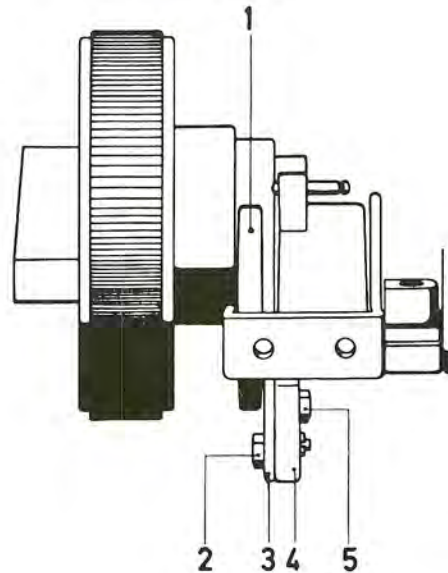

Fig. 8a



### Adjustment:

Take out the screws of the arm standard cover and remove the latter. Loosen hexagon screw 5 (Fig. 8a) about a quarter turn, using a 5.5-mm ring spanner, so that lever 3 bears against stitch width lever 4 just lightly. With the same ring spanner now turn eccentric stud 2 until the needle bar is zeroed correctly. To determine the correct zero position, let the machine run slowly and watch the long connecting rod and the roller which is in contact with the needle vibrating lever. If the connecting rod no longer moves, lightly tighten the hexagon screw.



**Note:**

If eccentric stud 2 has been turned too far, the roller moves below the pivot of the needle vibrating lever, thus causing the latter to lift clear of the needle vibrating eccentric so that the zero position of the needle can neither be observed nor adjusted.

**Verification:**

After this adjustment, let the needle prick into a piece of cardboard again (see under "Check" above). If the setting is correct, tighten hexagon screw 5 securely. Stitch width lever 4 should now work smoothly.

**9. Adjusting the Needle Vibration Controlled by the Zigzag Mechanism**

---

**Rule:**

In zigzag sewing, the needle should start swinging sideways after it has risen clear of the thickest material normally sewn on this machine. The sideways motion should commence when the needle point has just left the needle plate slot and should be completed before the needle enters the fabric again, i.e. when its point has reached a position about 7 mm (9/32") above the needle plate (Fig. 9)

Fig. 9

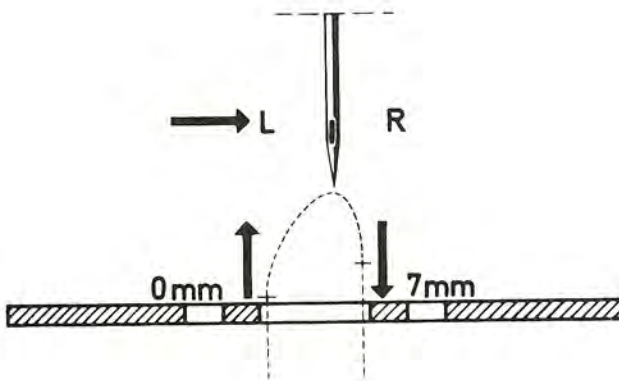
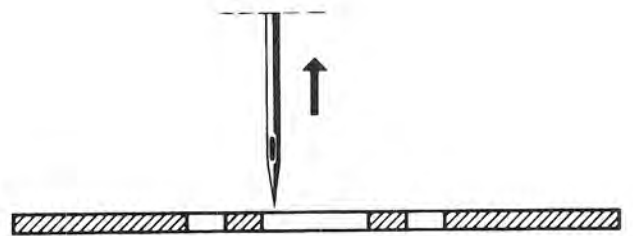
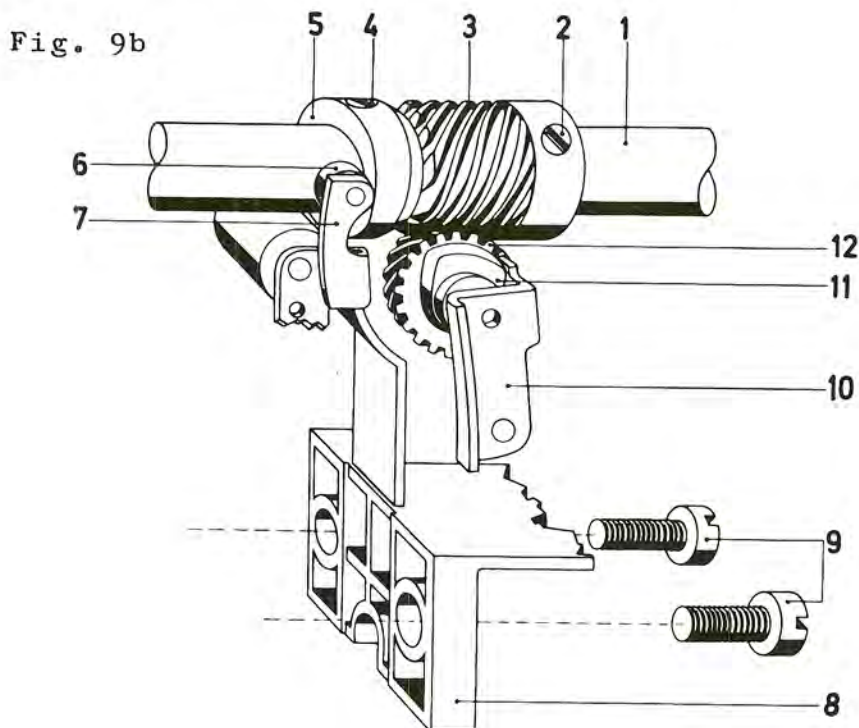

Fig. 9a



**Check:**

Turn the master selector dial to stitch range 8 and the needle position knob to the central needle position. Turn the balance wheel in sewing direction until the point of the needle ascending on the left of its throw is flush with the surface of the needle plate (Fig. 9a). Place your left forefinger against the needle bar frame and the arm casting. When rotating the balance wheel slowly, you can thus tell exactly when the needle vibration begins.



**Adjustment:**

If adjustment is required, loosen both screws 2 of worm 3 (Fig. 9b). Turn the balance wheel in sewing direction until the point of the ascending needle is flush with the surface of the needle plate (Fig. 9a). Hold the balance wheel fast while turning worm 3 in the normal direction of arm shaft rotation until the needle is beginning to swing from the left of its throw toward the right again. With the needle in this position, lightly tighten one of the two screws 2. If no screw should be accessible in this position of worm 3, turn the worm to move it toward the right out of mesh with the worm wheel, but make sure the latter is not turned in the process. Slightly turn the worm and bring it in mesh again so that one of its screws will be accessible when it is in contact with eccentric 5. Then fully tighten both screws 2.

**Verification:**

Check the needle vibration as instructed under "Check" above.

## 10. Adjusting the Needle Position

### Rule:

With the machine set for straight stitching and the needle position knob turned to the right or left position, the needle should enter the needle plate slot at exactly the same point as when the machine is set for its widest zigzag stitch.

Fig. 10

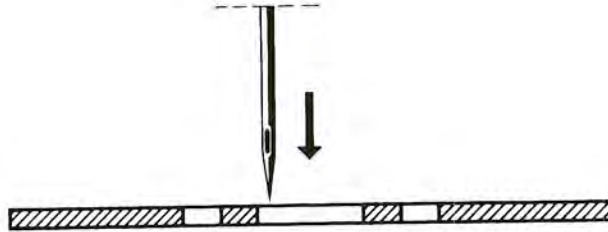

### Check:

Turn the master selector dial to the widest zigzag stitch in stitch range 9 and the knob on the dial to the left needle position. Turn the balance wheel until the needle is on the left of its throw and its point is flush with the surface of the needle plate (Fig. 10). As you turn the master selector dial from the narrowest to the widest zigzag stitch in stitch range 9, the needle must not make any perceptible sideways motion.

Fig. 10a

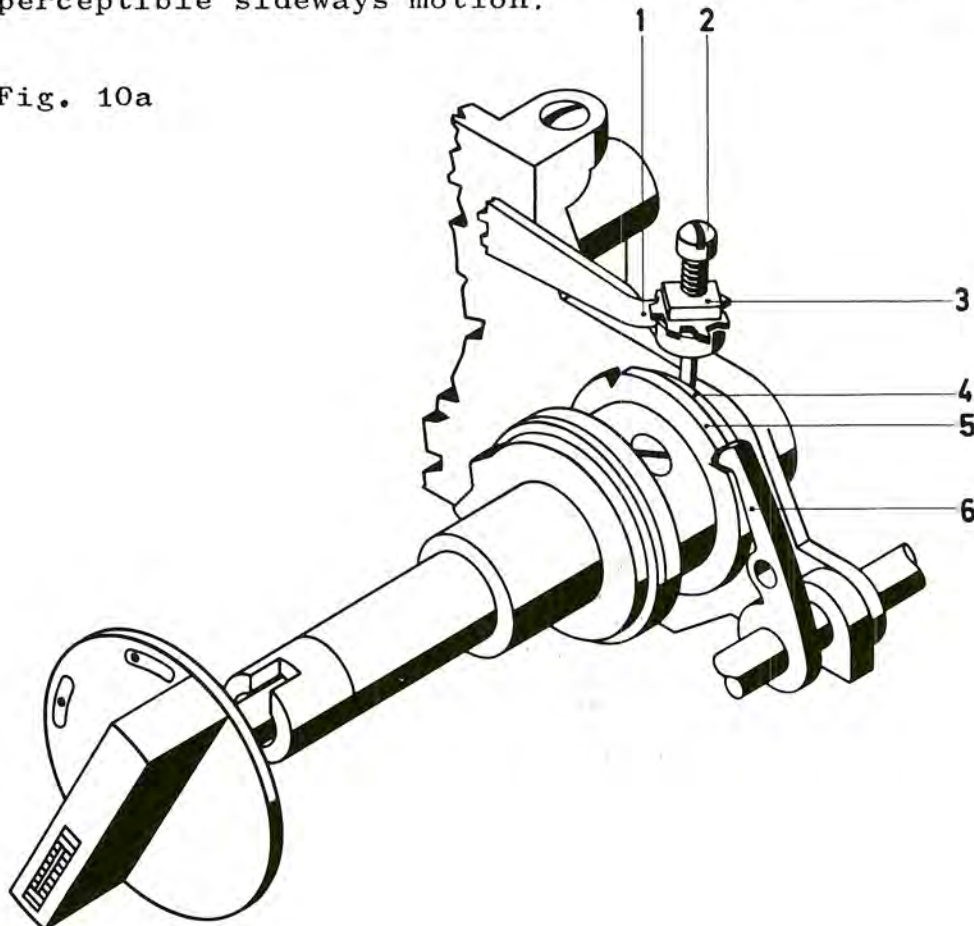



**Adjustment:**

If the needle does move, the position of needle position lever 1 (Fig. 10a) has to be adjusted by turning screw 2. Turn this screw out about three turns, but do not loosen lock nut 3. Turn the master selector dial from the narrowest to the widest zigzag stitch in stitch range 9 and back, while simultaneously turning in screw 2 slowly until the needle bar ceases vibrating. Screw 2 is retained in this position by lock nut 3.

**Verification:**

Now double-check exactly as instructed under "Check" above, with the needle moved to its left position.

11. Centering the Needle Throw in the Needle Plate Slot

**Rule:**

With the knob on the dial turned to the central needle position, the needle should clear both ends of the needle plate slot at the same distance when descending on the right and left of its throw (Fig. 11).

**Check:**

Turn the master selector dial to stitch range 8 and the needle position knob to the central needle position. Then turn the balance wheel and check to see if the needle clears both ends of the slot at the same distance.

Fig. 11

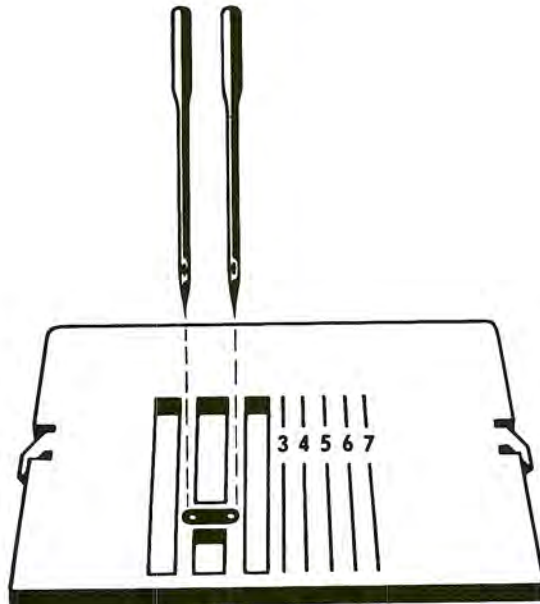

Adjustment:

Loosen both screws of the face cover and remove the latter. Insert a new needle (System 130, No. 80). Also loosen screw 3 in needle bar frame 1 (Fig. 11a). Take a 5.5-mm spanner and turn eccentric stud 5 until the needle clears both ends of the needle plate slot at the same distance as it descends on the right and left of its throw. When tightening the retaining screw again, make sure connecting rod 2 is allowed a small amount of end play.

Verification:

Check the end play of the connecting rod and the clearance between the needle and the ends of the needle plate slot with the machine set for its widest zigzag stitch.

Fig. 11a

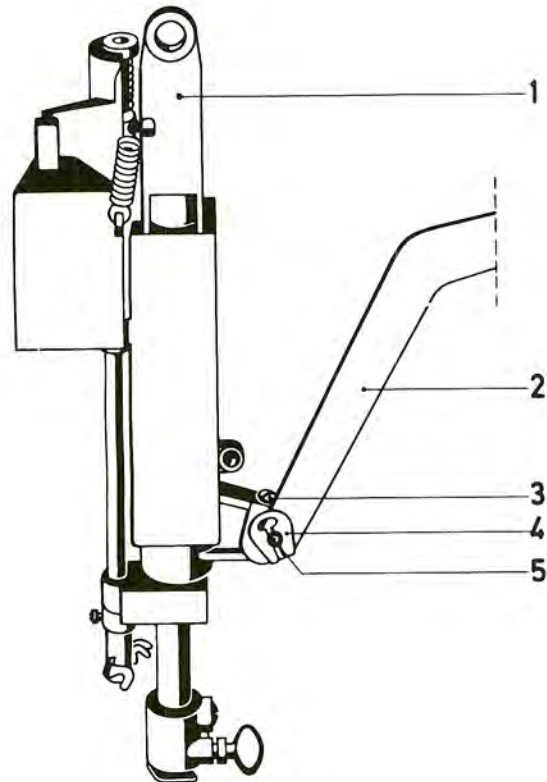



BUTTONHOLE MECHANISM

12. Operation of Buttonhole Mechanism

When buttonhole control 12 is pushed down against stop 13 while the buttonhole mechanism is in its starting position (Fig. 12), pawl 10 (Fig. 13) drops into a notch of the second ratchet wheel 9a and jointly turns all three ratchet wheels 9, 9a and 9b until pawl 8 (Fig. 12a) in its extreme left position can fall into the second notch of the first ratchet wheel 9. When the machine is running, all three ratchet wheels then jointly turn by one tooth. When the needle is situated above the fabric the buttonhole mechanism shifts from right side to bar tack and from forward stitch to reverse stitch.

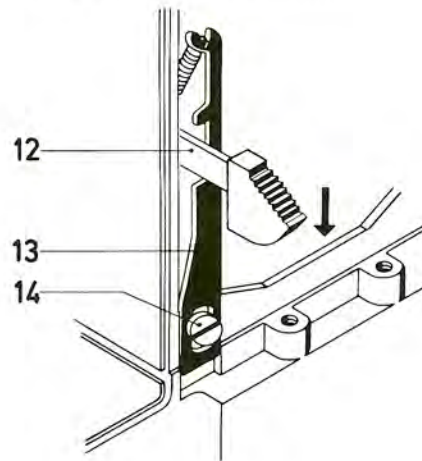

Fig. 12

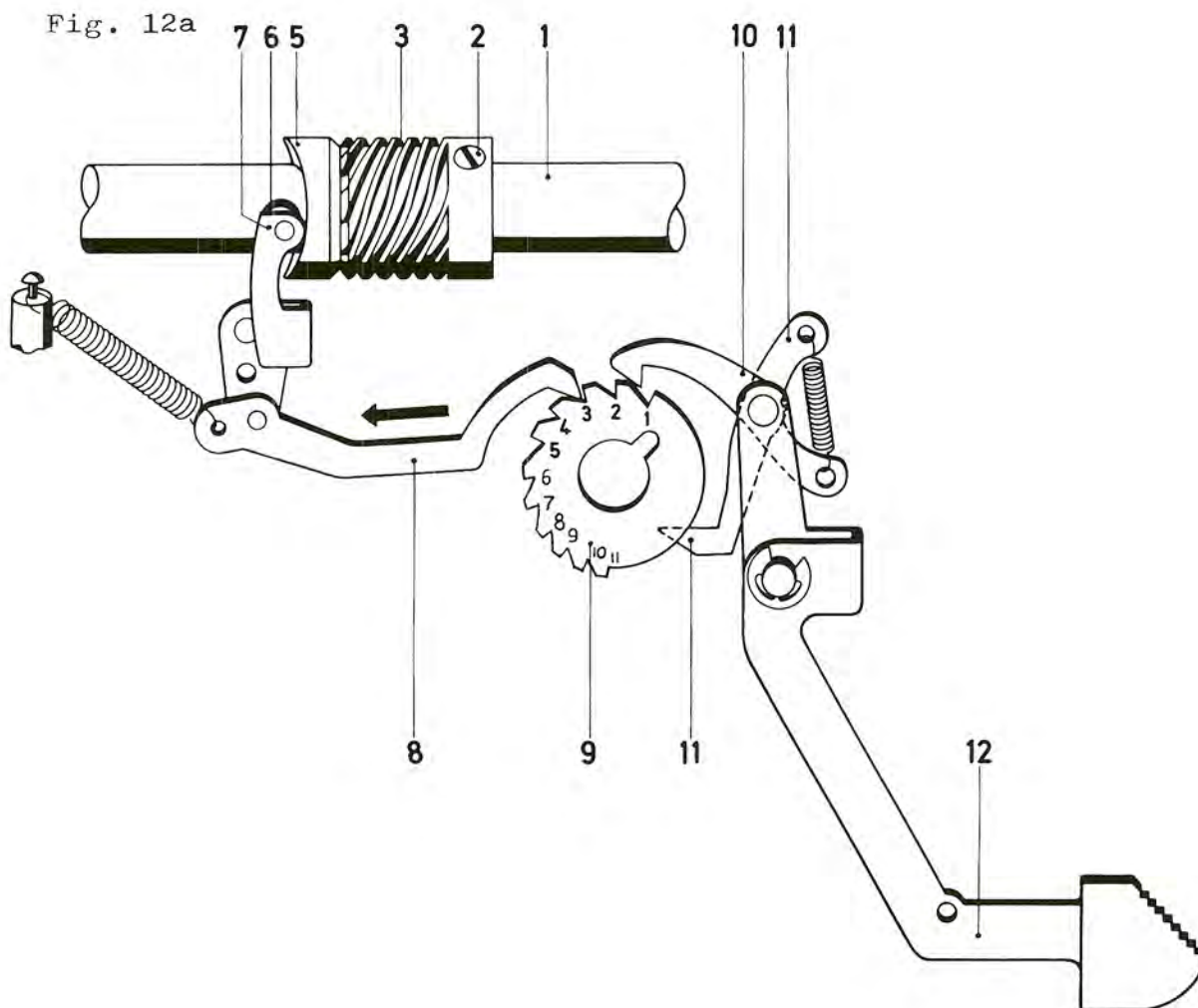

Fig. 12a

When buttonhole control 12 is released again, it returns to its top position and, while doing so, operates the lower pawl 11 (Fig. 12b) which turns the third ratchet wheel 9b until pawl 8 (Fig. 12a) in its extreme left position can fall into the third notch of the first ratchet wheel. At this point, there should be a clearance of 0.2 to 0.4 mm (.008" to .016"), as shown in Fig. 12a. As you continue turning the balance wheel, pawl 8 jointly turns all three ratchet wheels by one tooth and the top pawl 10 drops into the fourth notch of the second ratchet wheel 9a (Fig. 13). Hereby the buttonhole mechanism shifts from bar tack to left side.

When buttonhole control 12 is pushed down a second time the shifting procedure at ratchet wheel 9 is repeated. Hereby the buttonhole mechanism shifts from left side to bar tack and from reverse stitch to forward stitch.

When buttonhole control 12 is released again the shifting procedure at ratchet wheel 9b (Fig. 12b) is repeated. The buttonhole mechanism shifts from bar tack to straight stitch. Pawl 8 drops into notch 6 and at each top shaft turn into the next tooth until notch 11 is reached. Hereby all ratchet wheels and the complete cam stack are turned. The needle position knob (Fig. 6) moves to vertical end position.

Fig. 12b

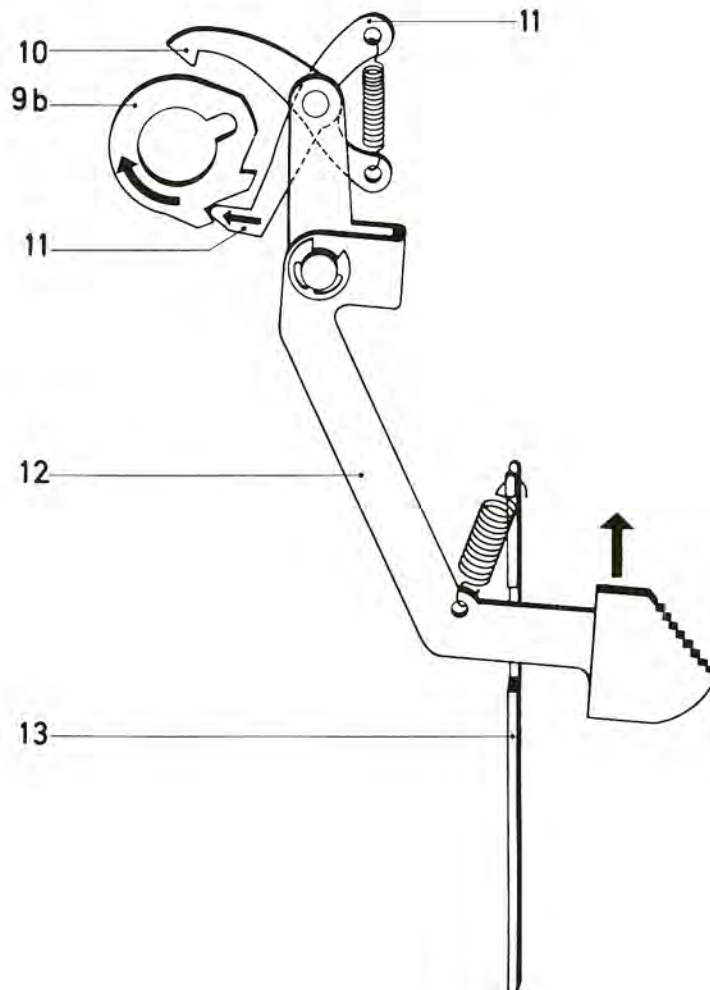

### 13. Basic Position of Buttonhole Control Stop

**Rule:**

With the buttonhole mechanism in its starting position, stop 13 of buttonhole control 12 (Fig. 13a) should be so positioned that the upper pawl 10 (Fig. 13) has dropped into the first notch of the second ratchet wheel 9a and clears the first tooth at a distance of 0.2 to 0.4 mm (.008" to .016").

Fig. 13

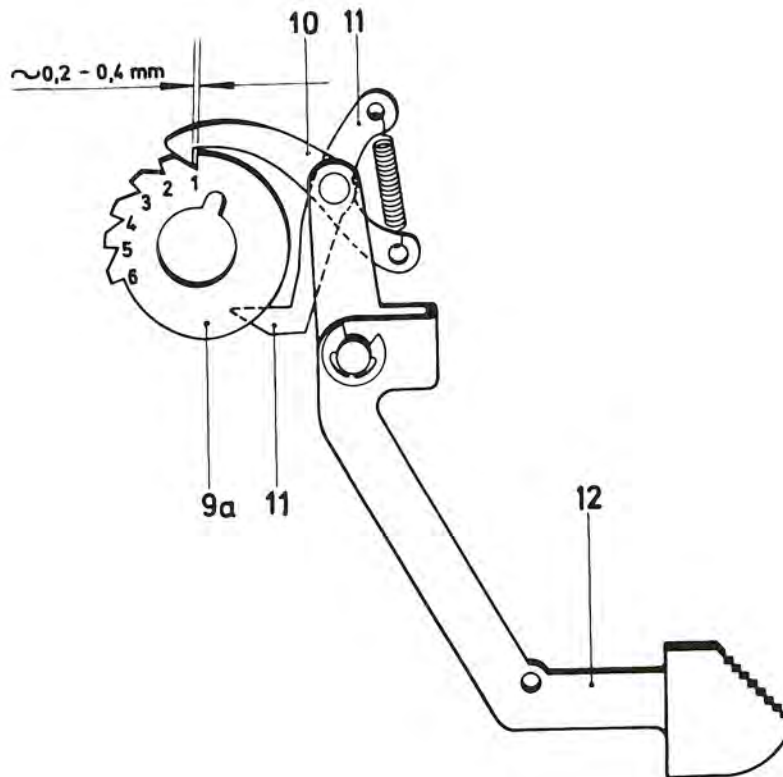

**Check:**

Turn the needle position knob until the buttonhole symbol on its one end is opposite the white mark on the dial. Then check to see if the clearance between tooth and pawl is correct. It may be necessary to push the buttonhole control down by this distance.



Adjustment:

Loosen screw 14 and push stop 13 to its lowest position (Fig. 13a). Then tighten screw 14 only lightly. Turn the master selector dial and the needle position knob so that their buttonhole symbols are opposite the white mark. Now push up stop 13 with the aid of a screwdriver (Fig. 16c) until the upper pawl 10 (Fig. 13) falls into the first notch of the second ratchet wheel 9a and clears the first tooth at a distance of 0.2 to 0.4 mm. Now fully tighten screw 14 of the stop.

Fig. 13a

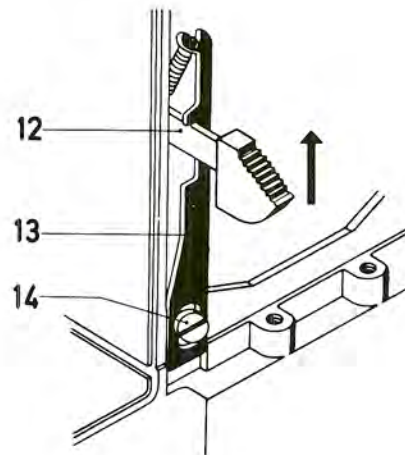

Verification:

Check the clearance between tooth and pawl as instructed under "Check" above.

14. Adjusting the Relative Position of Driving Pawl and Ratchet Wheel

Rule:

With the buttonhole mechanism in its starting position, driving pawl 8 should have completed its stroke toward the right when it is 0.1 mm (.004") away from the first tooth of the first ratchet wheel (Fig. 14).

Check:

Check this clearance visually and by lifting driving lever 7 off eccentric 5.

Fig. 14

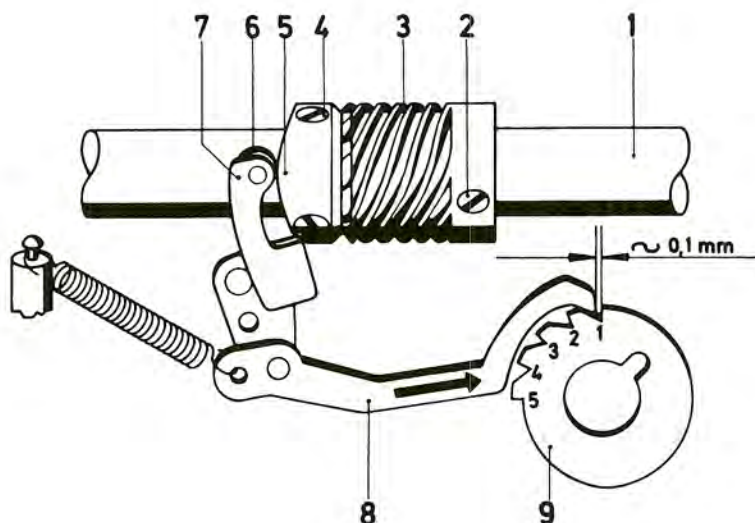

Adjustment:

Turn the master selector dial and its knob so that their buttonhole symbol are opposite the white mark. With the buttonhole mechanism in this position, pawl 6 should have dropped into the notch of ratchet wheel 5 (Fig. 10a). Loosen both screws 4 in eccentric 5 (Fig. 14) and rotate the latter until roller 6 of driving lever 7 is at the highest point of eccentric 5. Now push the eccentric toward the right or left until the clearance between pawl 8 and the first tooth of the first ratchet wheel 9 is 0.1 mm. Tighten both screws 4 in eccentric 5 securely again.

Note:

This adjustment may make it necessary to push worm 3 slightly toward the right. To do this, loosen both screws 2. To prevent disturbing the setting of worm wheel 12 and the needle vibrating eccentric (Fig. 9b), hold the worm wheel steady. Having adjusted the position of eccentric 5 (Fig. 15), push worm 3 toward the left against eccentric 5, without disturbing the setting of worm wheel 12 and tighten both set screws. Again check the timing of the needle vibrating motion, as instructed in Section 9, and, if necessary, readjust. Make sure worm 3 is constantly in contact with eccentric 5.

Verification:

Turn the balance wheel and check to see if there is a clearance of 0.1 mm between pawl 8 and the first tooth of the first ratchet wheel when the pawl is at its right point of reversal.

15. Timing the Pawl Stroke

Rule:

When the buttonhole control has been operated for the first time and the point of the ascending needle is flush with the surface of the needle plate, pawl 8 on its travel toward the right should contact the second tooth of the first ratchet wheel 9 and, as the machine continues running, should turn this wheel clockwise (Fig. 15).

Fig. 15

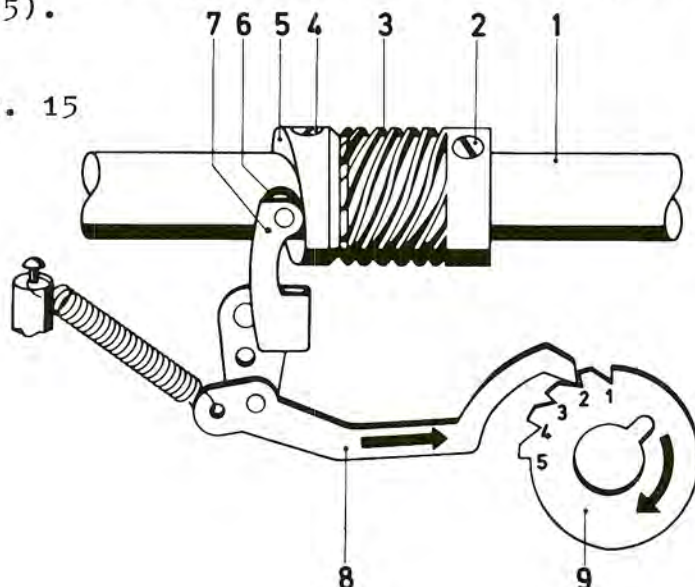



**Check:**

Turn the master selector dial to the buttonhole sewing position. Depress the buttonhole control and hold it there. Turn the balance wheel and make a visual inspection.

**Adjustment:**

Loosen both screws 4 in eccentric 5. Turn the master selector dial and its knob until their buttonhole symbols are opposite the white mark. Now rotate the balance wheel until the point of the ascending needle is flush with the surface of the needle plate (Fig. 15a). Press buttonhole control 12 down against stop 13 (Fig. 15b) and hold it there. Turn eccentric 5 in the normal direction of arm shaft rotation until pawl 8 contacts the second tooth of the first ratchet wheel 9. Then tighten both screws 4 of eccentric 5, making sure that the latter bears against worm 3.

Fig. 15a

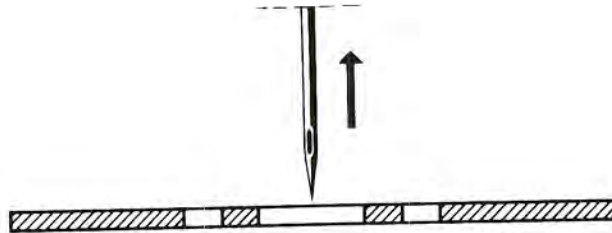

**Verification:**

Turn the master selector dial to the buttonhole sewing position. Depress the buttonhole control and hold it there (Fig. 15b). Rotate the balance wheel until the point of the ascending needle is flush with the surface of the needle plate and check to see if the pawl now contacts the second tooth of the first ratchet wheel.

Fig. 15b

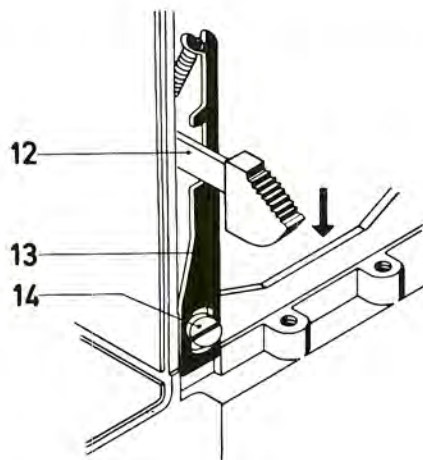

16. Final Adjustment of the Buttonhole Control Stop

Rule:

Stop 13 of buttonhole control 12 (Fig. 16) should be so positioned that the upper pawl 10 and the lower pawl 11 (Fig. 16a) will alternately fall into the respective notch as the buttonhole sewing cycle is in progress.

Fig. 16

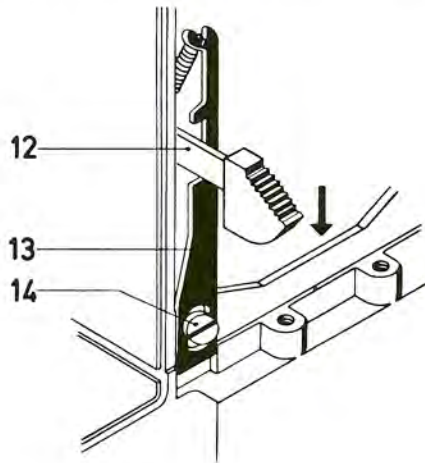

Checking the first phase of the buttonhole sewing cycle:

Turn the master selector dial to the buttonhole sewing position. Push the buttonhole control down against its stop and hold it there (Fig. 16). Rotate the balance wheel one complete turn in sewing direction. As you do this, the lower pawl 11 (Fig. 16a) should fall into the first notch of the third ratchet wheel 9b, which can be ascertained by watching the top end of pawl 11. Continue turning the balance wheel until driving pawl 8 (Fig. 16b) is exactly at its left point of reversal. Release the buttonhole control. The lower pawl 11 should now rotate ratchet wheel 9b (Fig. 16a).

Fig. 16a

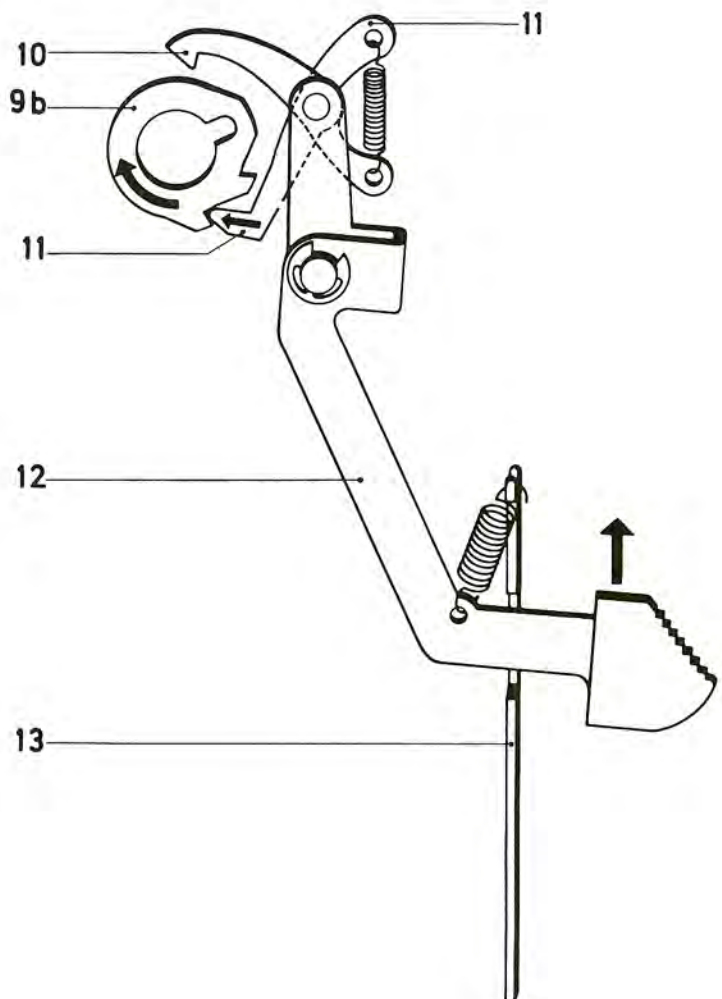

The clearance between the driving pawl and the third tooth of the first ratchet wheel should now be 0.2 to 0.4 mm (Fig. 16b).

Fig. 16b

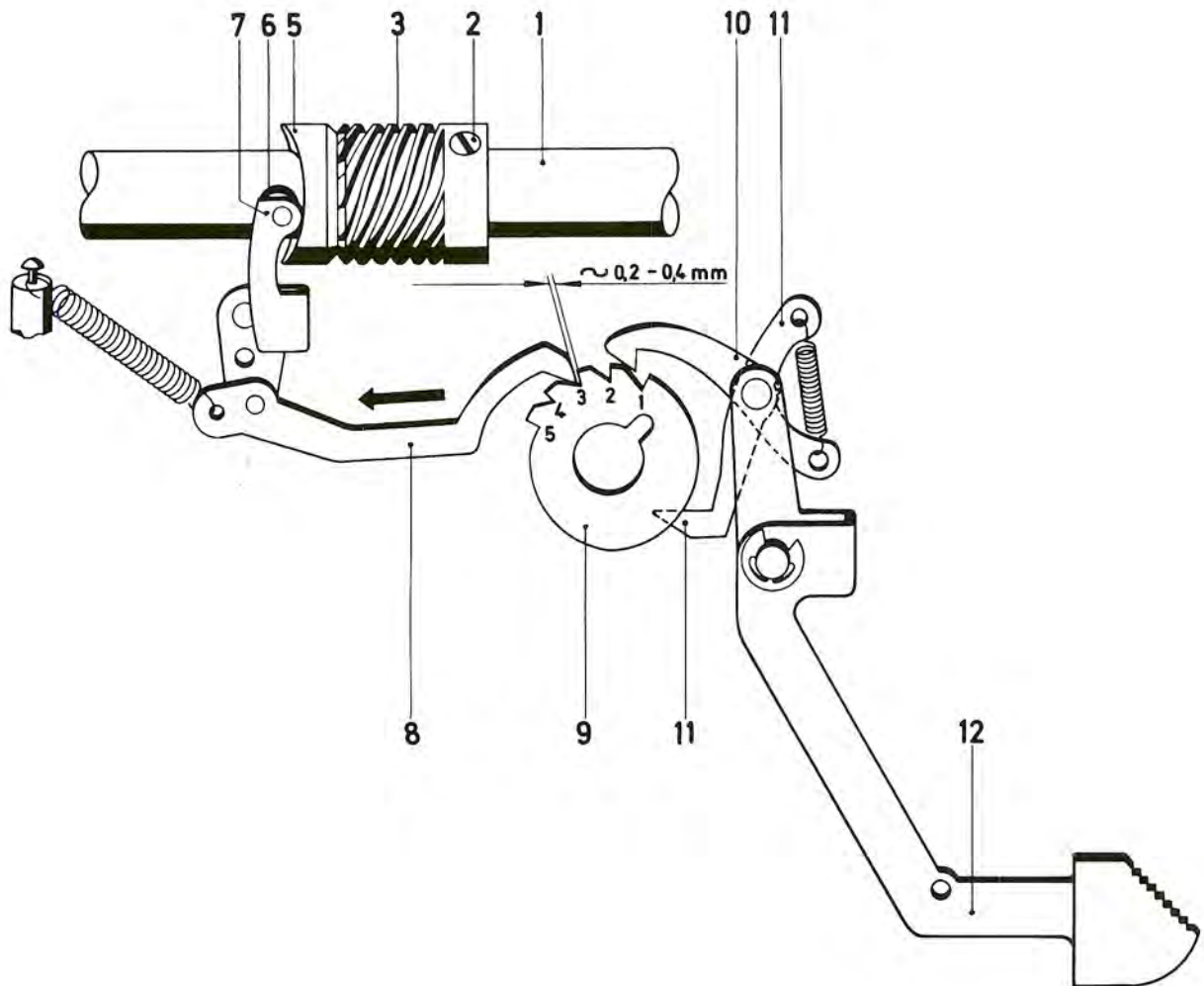

Continue turning the balance wheel until driving pawl 8 is at its right point of reversal again. With the pawl in this position, the upper pawl 10 should now drop into the fourth notch of the second ratchet wheel 9a (Fig. 13).

Checking the second phase of the buttonhole sewing cycle:  
Again depress the buttonhole control and hold it in its lowest position. Rotate the balance wheel one complete turn and release the buttonhole control again. Then rotate the balance wheel one complete turn again and, as you do this, check the second phase of the buttonhole sewing cycle in the same manner.



Adjustment:

If this check reveals that the lower pawl 11 (Fig. 16a) does not fall into the appropriate notch, loosen screw 14 (Fig. 16c) and slightly push stop 13 downward.

If the upper pawl 10 (Fig. 13) does not drop into the fourth notch of the second ratchet wheel 9a, set stop 13 higher accordingly. Fully tighten screw 14 again (Fig. 16c).

Verification:

Check the proper working of the pawls by operating the buttonhole control and turning the balance wheel, as instructed above (under "Checking both phases of the buttonhole sewing cycle).

Fig. 16c

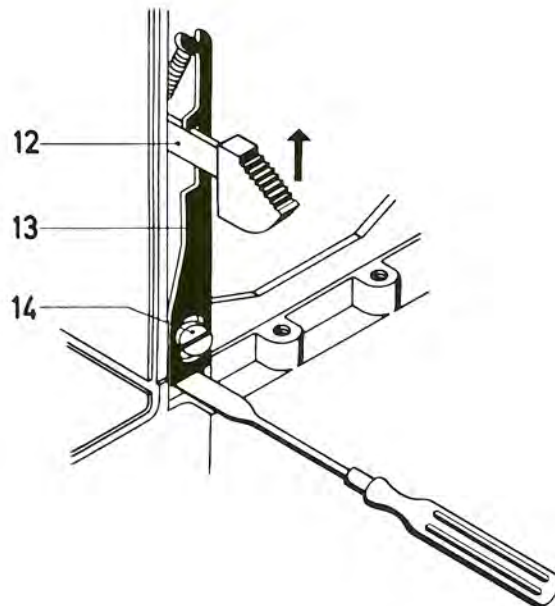

17. Timing the Buttonhole Forward-Reverse Feed

If all settings of the machine feed are correct, the timing of the buttonhole forward-reverse feed discussed in Section 33 may be carried out at this point.

FEED MECHANISM

18. Lateral Adjustment of Feed Dog

Rule:

The feed dog should be positioned so that its tooth rows are centered exactly in the feed slots and do not chafe against the side walls (Fig. 18).

Fig. 18

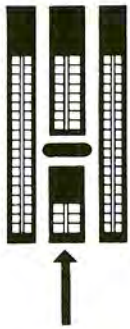

Fig. 18a

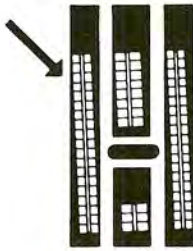
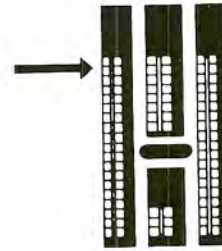

Fig. 18b



Check:

Check to see if the feed dog is positioned correctly.

Adjustment:

If the feed dog is wedged in the feed slots or not centered properly (Figs. 18a and 18b), remove the needle plate and loosen both screws 2 (Fig. 18c). Then adjust the position of the feed dog in the feed slots.

Fig. 18 c

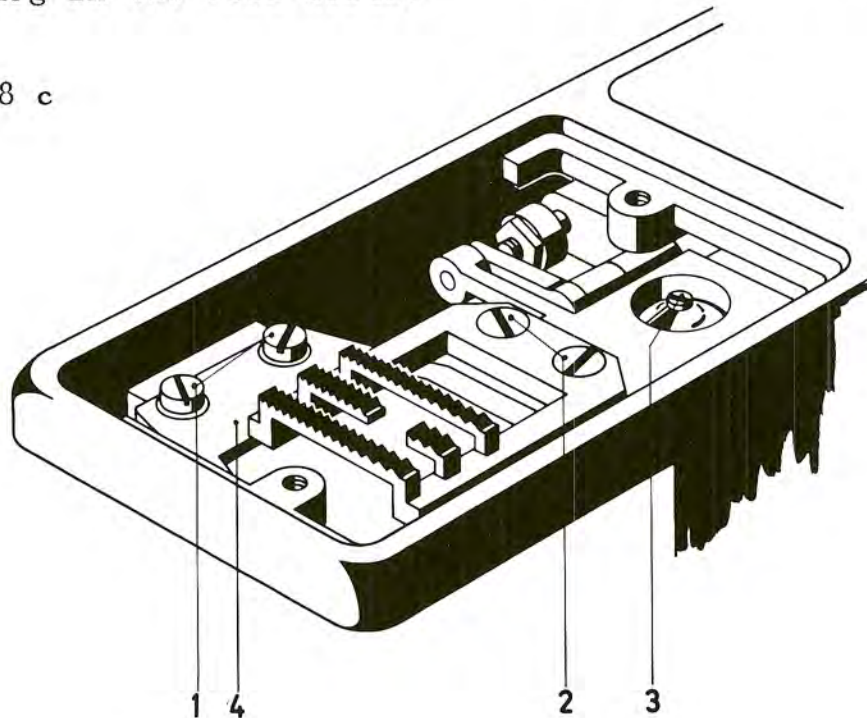

If the feed dog is much closer to one side than the other, loosen screws 1 and 13 of the hook drive shaft bushings (Fig.18d). To get at these screws, remove the bottom plate on flatbed machines or the base plate and the free arm bottom cover on free-arm machines. This done, move hook drive shaft 7 together with its bushings 2 and 11 and feed rock shaft 9 to the right or left until the feed dog is correctly centered in the feed slots. Tighten screws 1 and 13 securely again, making sure that feed rock shaft 9 has neither too much nor too little end play.

Fig. 18d

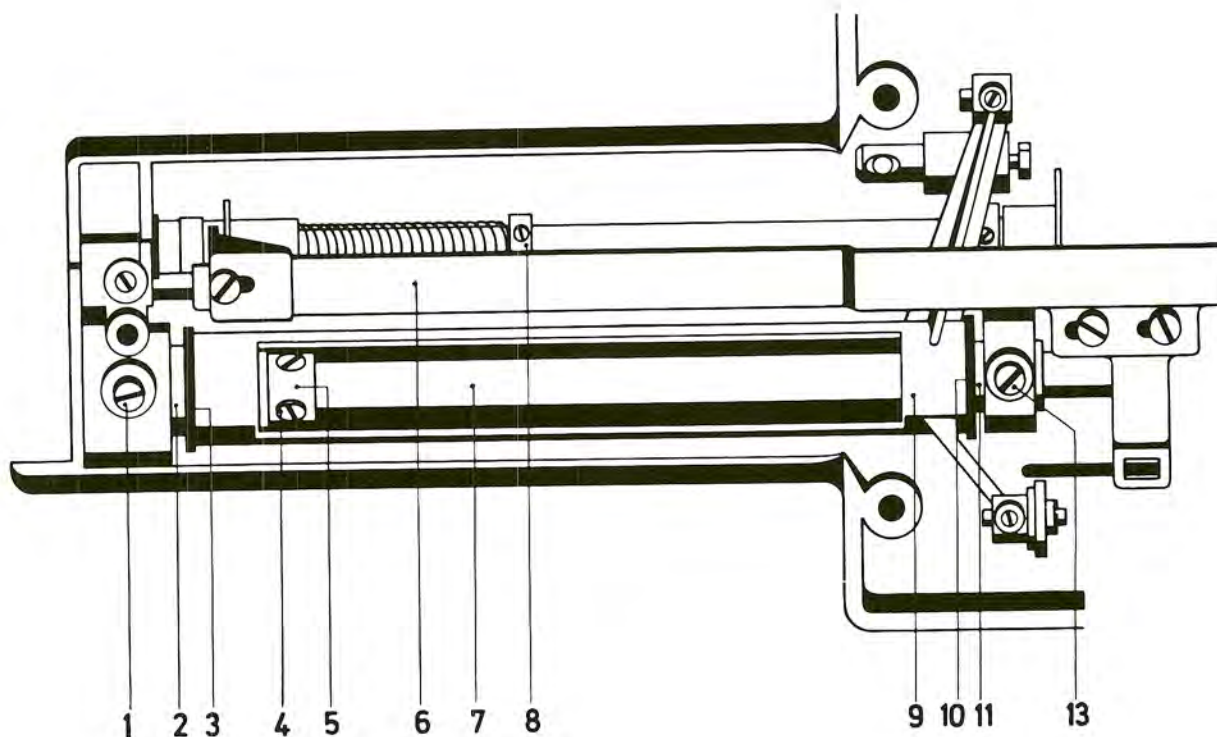

Note:

The foregoing adjustment may have disturbed the hook-to-needle setting.

Verification:

Check to see if the feed dog is correctly centered in the feed slots of the needle plate (Fig. 18).



### 19. Setting the Feed Dog Parallel to the Needle Plate

Rule: ( old version )

When the feed dog is at its highest position, its teeth should be parallel to the surface of the needle plate (Fig. 19).

Fig. 19

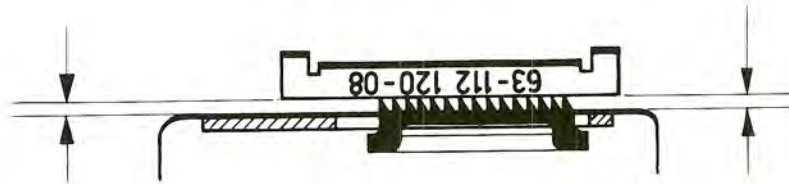

Check:

Bring the feed dog to its highest point and turn the master selector dial to the longest stitch. Place gauge No. 63-112 120-08 on the feed dog with its recessed surface facing upwards. Now check whether there is the same amount of clearance between needle plate and gauge at both ends of the gauge.

Adjustment:

If the feed dog is not parallel, remove the bottom plate on flatbed machine or the base plate and the free arm bottom cover on free-arm machines. Then, using a 7-mm open-ended spanner, loosen hexagon screw 34 (Fig. 19a) and set fulcrum stud 38 higher or lower until the feed points are exactly parallel with the needle plate surface. Lightly

Fig. 19a

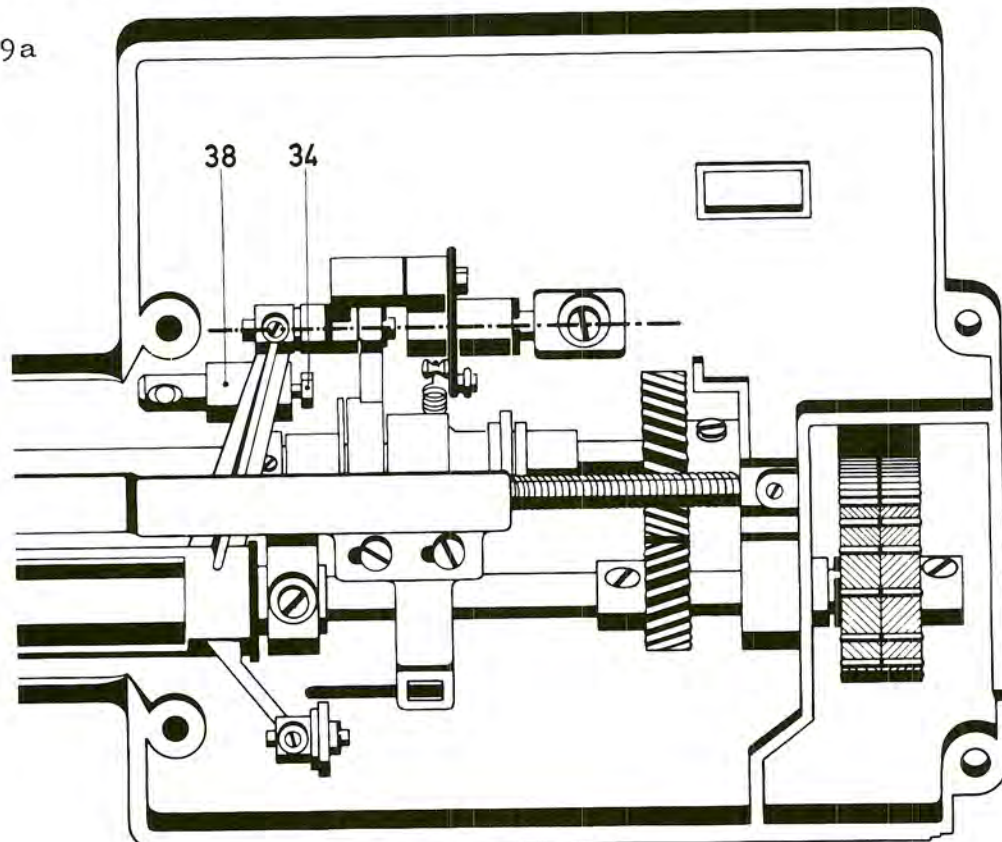

tighten screw 34 again. Loosen the small screw in the feed rocking bar to free fulcrum stud 38, in case it should bind. Then tighten the small screw again and check to make sure the feed dog carrier has no play.

**Verification:**

Place the gauge on the feed dog and check to see if its teeth are parallel to the needle plate surface. If its position is correct, fully tighten hexagon screw 34. Again check the parts involved in this adjustment for free movement.

19a. Setting the feed dog parallel to the needle plate

(new version)

**Rule:**

When the feed dog is at its highest position, its teeth should be parallel to the surface of the needle plate (see Fig. 19b).



Fig. 19b

Set the machine for the longest stitch length and bring the feed dog to its highest position. Place gauge No. 63-112 120-08 on the feed dog with its recessed surface facing upwards. Now check to see whether the feed dog is set parallel to the needle plate (see Fig. 19b).

**Adjustment:**

If it is not, remove the bedplate cover on flatbed machines or the bottom plate and the free-arm cover on free-arm machines. Then, using an 8-mm-wide spanner, loosen hexagon screw 34 (Fig. 19c) and set guide piece 38 higher or lower until the feed dog is exactly parallel to the needle plate.

Tighten screw 34.

Loosen screw 35 and remove the circlip on stud 36. Remove stud 36. Loosen screw 12 and remove stud 14.

Loosen the small screw 41 in feed bar 40, and disconnect the tension spring under the feed dog. Then move feed rock shaft 9 back and forth until it moves freely.



Tighten screw 41 in feed bar 40 and again check to make sure that all parts move freely. There must be no play now between feed bar 40 and the circlip of the small stud 39.

Insert stud 14 and tighten screw 12. Check the top and bottom feed mechanisms for free movement, since in case of heavy working the stitch length would differ in forward and backward feeding when making the two buttonhole seams.

Mount stud 36 with the circlip, push the feed regulator links up against each other and tighten screw 35.

Verification:

Place gauge No. 63-112 120-08 on the feed dog and check for parallelism. Tighten all screws securely and check to see that the feed regulator links reverse properly.

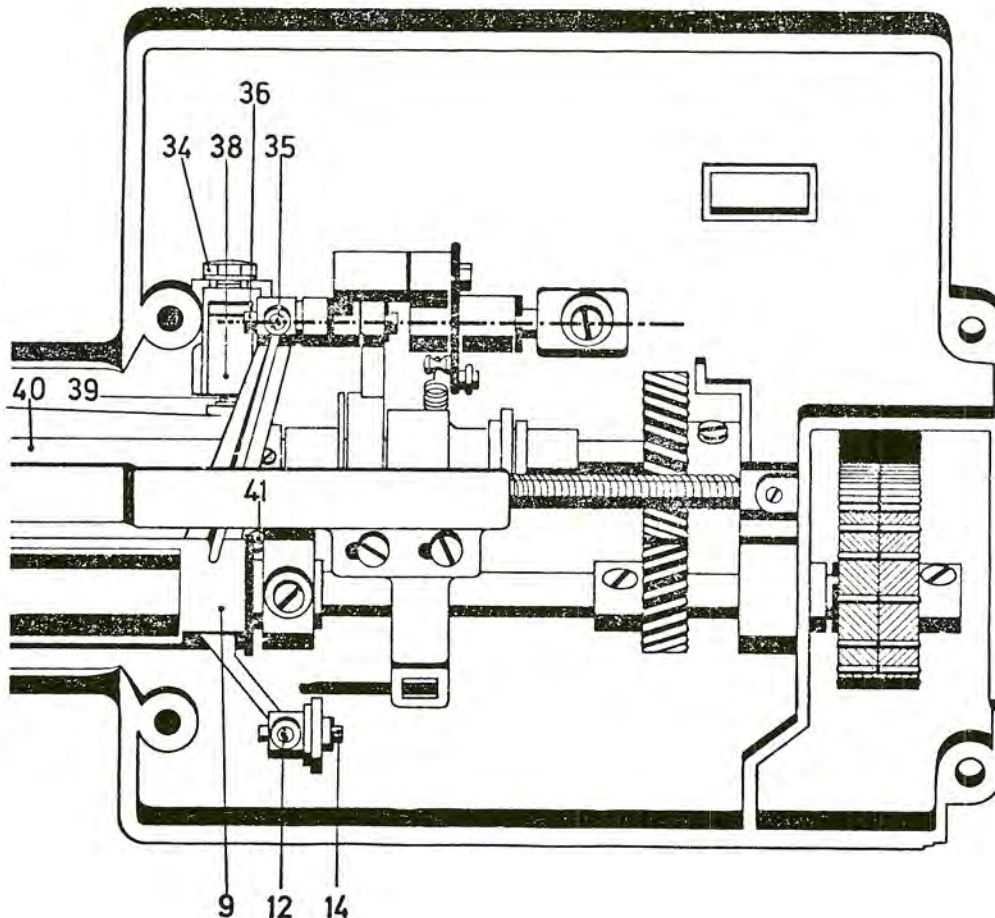

Fig. 19c

## 20. Setting the Feed Dog at the Correct Height

### Rule:

When the feed dog is at its highest position, its teeth should protrude 0.9 mm (.04") above the needle plate surface.

Fig. 20

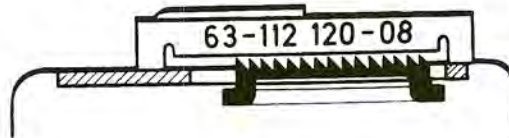

### Check:

Place gauge No. 63-112 120-08 on the needle plate so that its 1.0-mm recess is above the feed dog. Set the machine for its longest stitch and bring the feed dog to its highest position (Fig. 20).

### Adjustment:

If adjustment is required, remove the needle plate. On flatbed machines also unscrew the needle plate base. To set the feed dog higher or lower, turn screw 3 which is located to the right of the feed dog in the needle plate base (Fig. 20a). Turning this screw clockwise raises the feed dog, turning it counter-clockwise, lowers it.

Screw 3 is retained in its respective position by a retaining ring.

Screw 3 is retained in its respective position by a retaining ring.

Fig. 20a

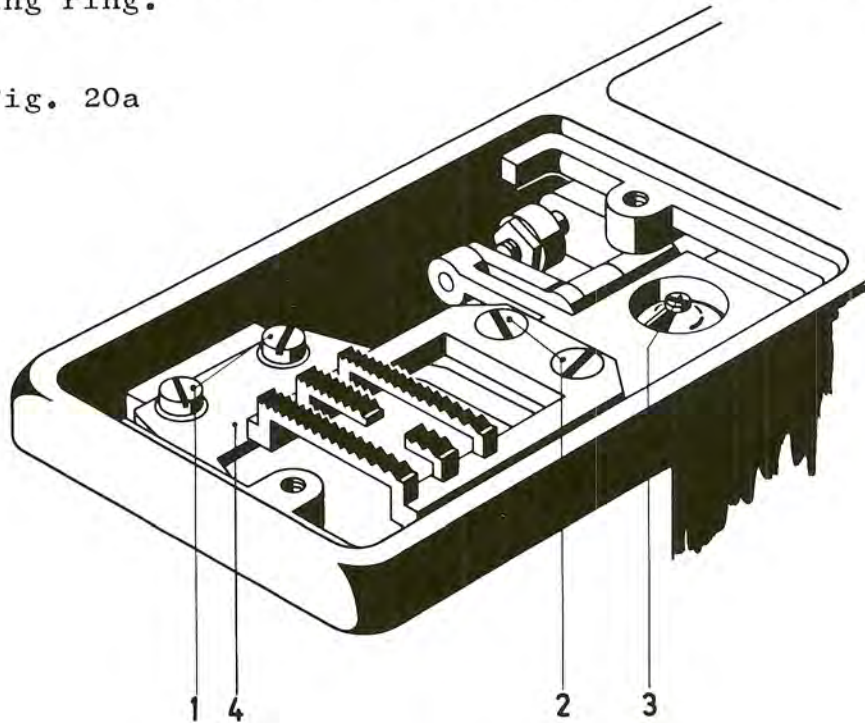

Verification:

To check this setting, replace the needle plate and bring the feed dog to its highest position. There should now be a clearance of 0.1 mm between the feed teeth and the underside of the recessed portion of the gauge (Fig.20).

21. Adjusting the Feed Eccentric Clutch Sleeve

A feed reversing clutch in the feed mechanism makes it possible to reverse the action of the feed eccentric for reverse sewing. As a result, the length of the reverse stitch is the same as that of the corresponding forward stitch.

Rule:

When the machine is set for forward sewing, clutch sleeve 24 (Fig. 21) should be positioned so far to the left that the stop spring on drive shaft 7 is up against the end of the slot in the clutch sleeve. At the same time, however, fork 26 of bar 6 must not be pressed against the wall of the annular guide groove on clutch sleeve 24 by spring pressure.



Check:

Swing the reverse-feed control from its right to its vertical position and back again. At the same time rotate the balance wheel and check the working of the feed clutch (sleeve).

Fig. 21

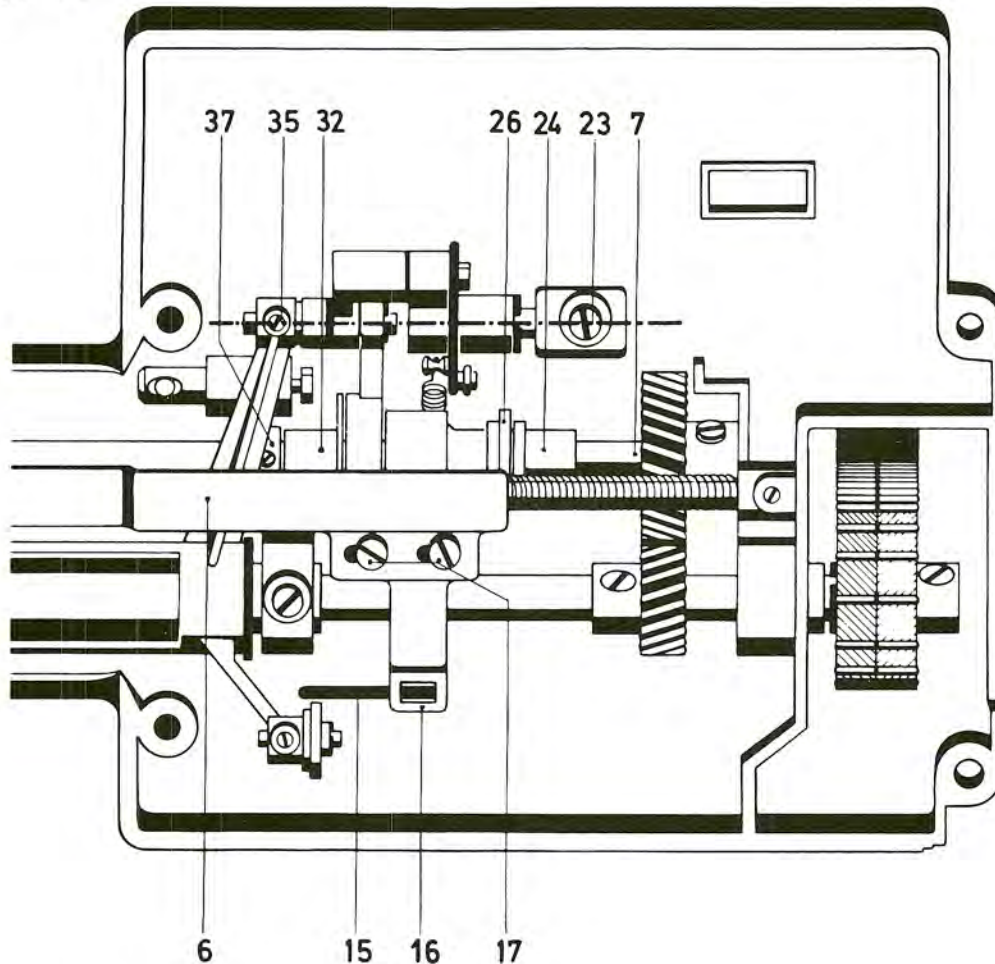

Adjustment:

Flick the reverse-feed control to the right (normal position). With the control in this position, lever 6 (Fig. 33) must not lift bellcrank 7 off the actuating cam of the reverse-feed control. If it does, loosen hexagon screw 5. Loosen collar 37 (Fig. 21) positioned to the left of feed eccentric 32 and push both parts toward the left by about 2 mm ( $5/64$ " ). Loosen both screws 17 on bar 6 as well as screws 35 and 23 on the connecting link and crank studs, respectively. Turn clutch sleeve 24 and simultaneously push it toward the left until the stop spring has snapped into position in its slot and bears against the end of the slot. Slightly push regulating bracket 16 toward the left against the long bellcrank 15. Then tighten both screws 17 securely. After this adjustment, bar 6 springs back lightly, thus relieving the spring pressure against the wall of the annular groove in the clutch sleeve.

**Verification:**

Operate the reverse-feed control while turning the balance wheel and check to see if the feed clutch works properly and reverses the direction of feed.

**22. Adjusting the Feed Eccentric Endwise**

**Rule:**

With the reverse-feed control at its normal (right) position, there should be a clearance of 0,2 mm (.004") between the feed eccentric and the clutch sleeve when the latter has snapped into position properly.

**Adjustment:**

To adjust, loosen collar 37 (Fig. 22) and push feed eccentric 32 together with the collar toward the right until a clearance of 0,2 mm is obtained between clutch sleeve 24 and the feed eccentric. If the flange of the feed eccentric pushes feed connection 31 toward the right, loosen screw 23 and push crank 28 slightly toward the right.

Fig. 22

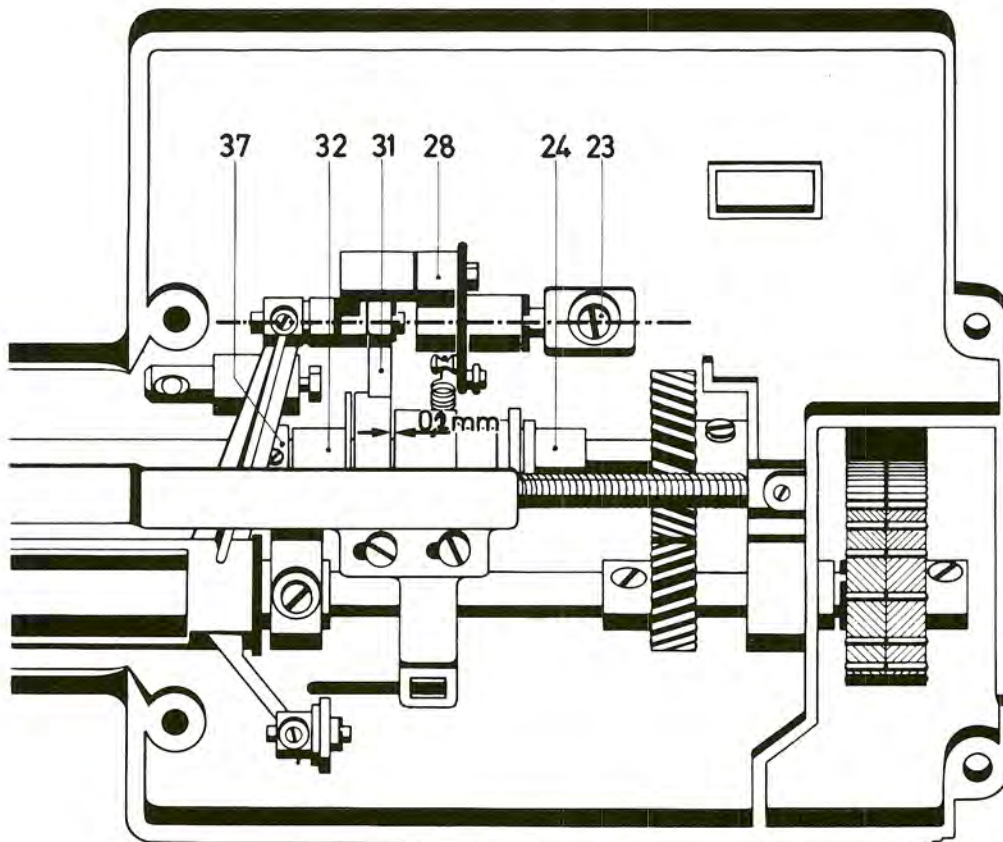

**Verification:**

Tighten the screws on collar 37 securely and check the above clearance.



### 23. Adjusting the Link-Type Feed Regulator Endwise

**Rule:**

The connection of the link-type feed regulator should lightly bear against the flange of the feed eccentric. In addition, the various component parts of the feed regulator should have no end play.

**Check:**

To check this, make a visual inspection and push the parts from side to side a few times.

**Adjustment:**

Loosen screws 23 and 35 (Fig. 23) and push stud 25 toward the left until all parts of the feed regulator are close together and feed connection 31 is in contact with the flange of feed eccentric 32. Lightly tighten screw 23. Then push stud 36 and connecting link 33 toward the right until they are up against connecting link 30. Then tighten screw 35 lightly.

Fig. 23

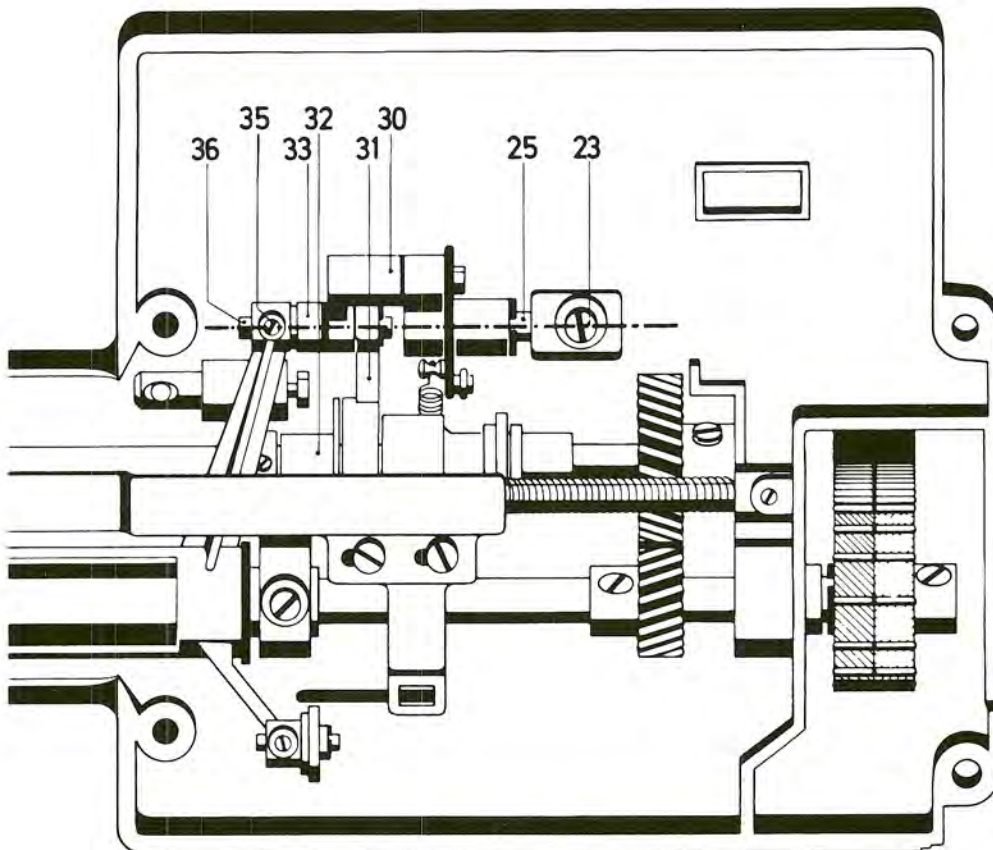

**Verification:**

Rotate the balance wheel and operate the reverse-feed control to check the smooth working of the feed regulator and proper reversing of the feed eccentric action. Fully tighten screws 23 and 35.



## 24. Zeroing the Feed Regulator

### Rule:

When the master selector dial is turned exactly to "0", the feed dog should move up and down only.

### Check:

Turn the master selector dial to "0" and place a piece of fabric under the sewing foot. Then run the machine and check to make sure the material is moved neither forward nor back.

### Adjustment:

On flatbed machines remove the bottom plate and on free-arm machines the base plate and the free arm bottom cover. Loosen hexagon screw 27 (Fig. 24), using a 5.5-mm spanner. Then adjust crank 28 and connecting link 30 until the centers of the studs in connecting link 33 and crank 28 are lined up exactly (see dash-dot line in Fig. 24). Now tighten hexagon screw 27 securely.

Fig. 24

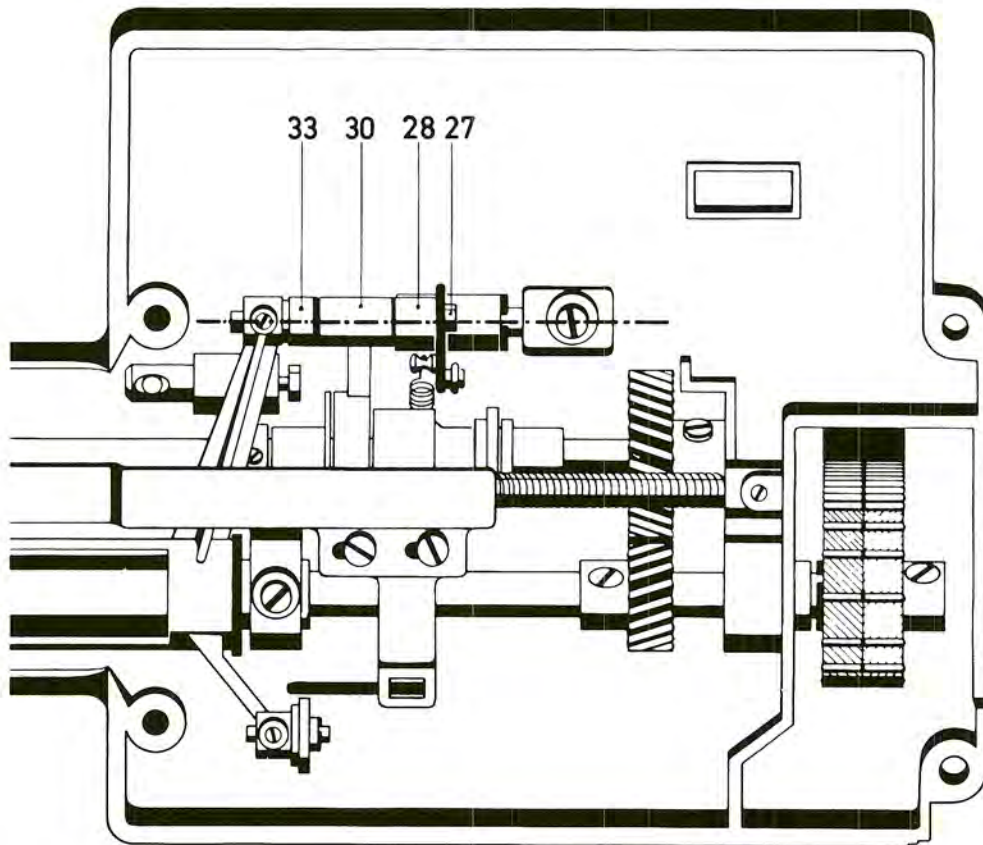

### Verification:

With the master selector dial set on "0", a piece of material placed under the sewing foot should move neither forward nor backward when the machine is running.

## 25. Timing the Top and Bottom Feed Strokes

### Operation:

The top and bottom feed motions are synchronized, i.e. when the feed dog rises, the feeding foot descends (Fig. 25). The material is gripped from the top and the bottom so that multiple plies will be advanced at exactly the same rate (Fig. 25a). At the end of the feed stroke, the feeding foot rises and the feed dog drops below the needle plate surface (Fig. 25b). The feeding foot and the feed dog then return to their starting position for the next stroke. On their return stroke, they are out of contact with the fabric (Fig. 25c). During the feed stroke, the presser bar is raised slightly (Fig. 25a), whereas the feeding foot which is screwed to a separate presser bar insert is lightly pressed down against the material by a second spring. This action keeps the material down and prevents flagging or creeping of the plies. Both the feeding foot and the feed dog begin advancing the material when the needle has risen clear of the goods. The feed stroke ends before the needle enters the fabric again.

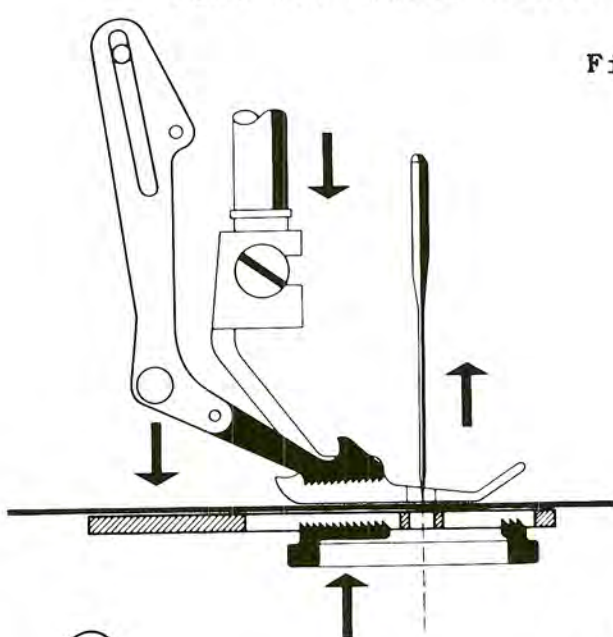

Fig. 25

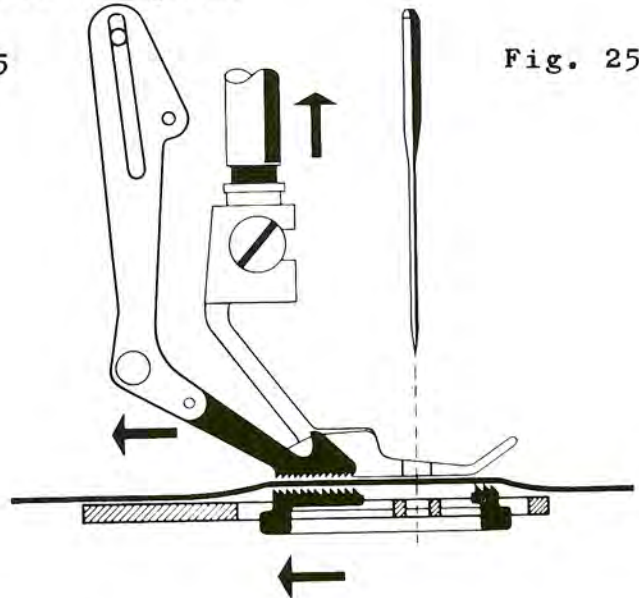

Fig. 25a

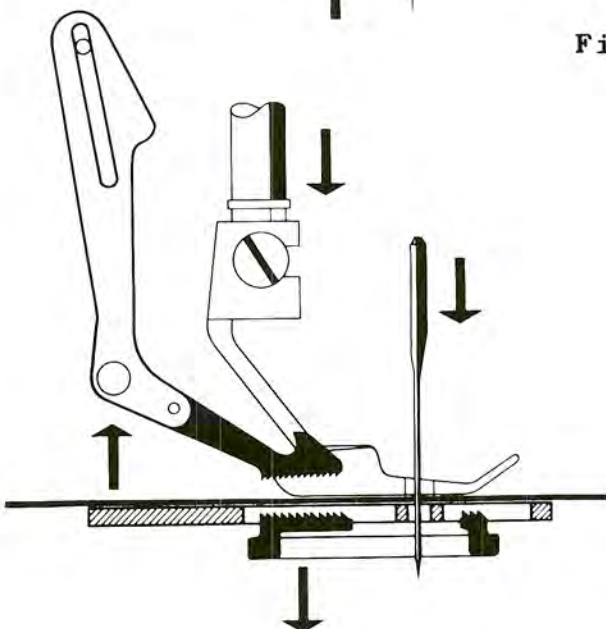

Fig. 25b

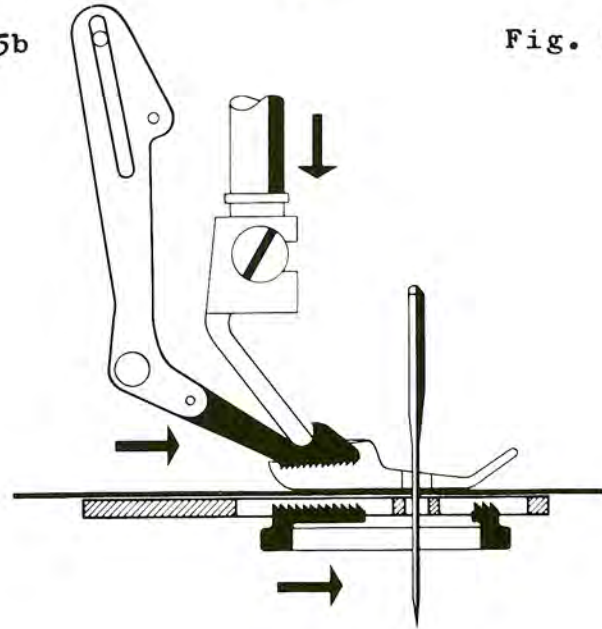

Fig. 25c



**Rule:**

With the needle bar in its highest position, the pivots of studs 25 and 29 in crank 28 and feed connection 31, respectively, should line up exactly (see dash-dot line in Fig. 25d).

**Check:**

Bring the needle bar to its exact highest point. Then turn the master selector dial back and forth between 0 and 4. As you do this, the feed dog should merely make a hardly perceptible motion.

**Adjustment:**

On flatbed machines remove the bottom plate and on free-arm machines the base plate. Loosen both screws 18 of the pinion (Fig. 25d). Turn the balance wheel to bring the needle bar to its exact highest position. Turn the master selector dial back and forth between 0 and 4. At the same time, turn steel pinion 19 in its normal direction of rotation until the feed dog is motionless above the needle plate and the pivots of studs 25 and 29 in crank 28 and feed connection 31, respectively, are exactly in line. Always turn the pinion forward, never backward. Lightly tighten one of the screws 18 on pinion 19.

Fig. 25d

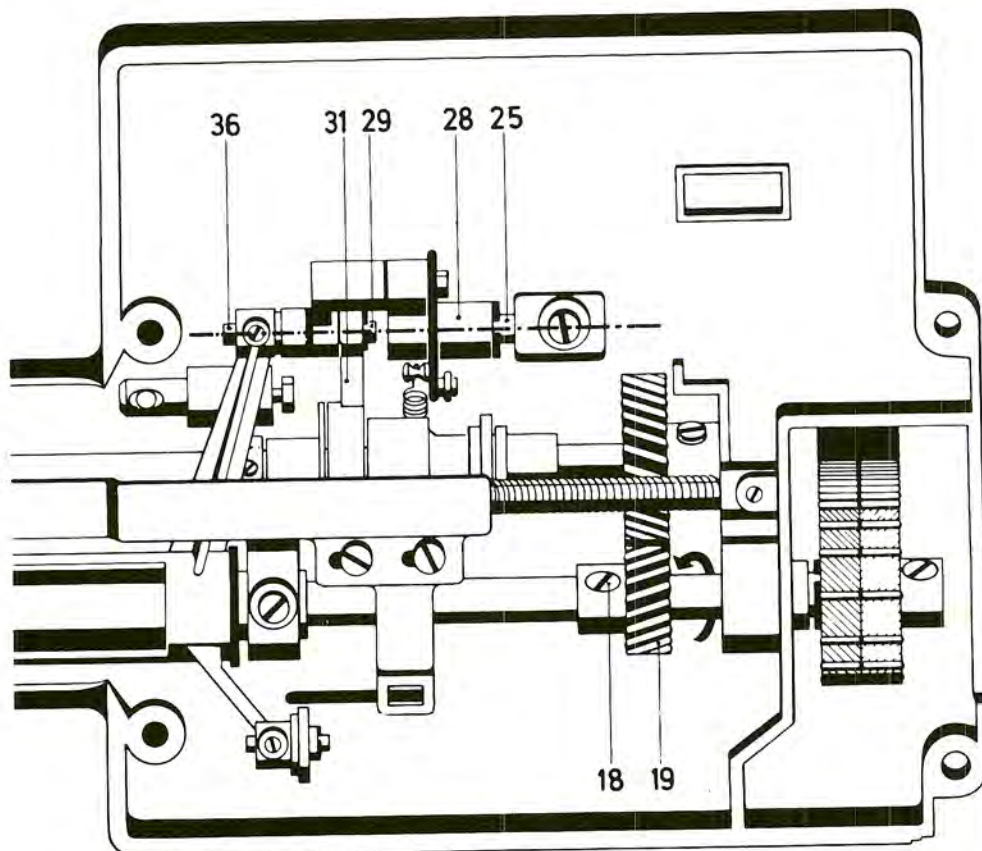

**Verification:**

Proceed as instructed under "Check" above. If the feed stroke exceeds 0.2 mm (.008"), repeat the above adjustment. Then securely tighten both screws 18.



## 26. Adjusting the Drop Feed Mechanism

### Rule:

With the reverse-feed control in its normal position, feed lifting eccentric 4 (Fig. 26) should bear against slip washer 2 under spring pressure. When eccentric 4 is in this position, its right edge should be below the right edge of eccentric follower 1 and the clearance between collar 8 and eccentric 4 should be approx. 25 mm (1").

Fig. 26

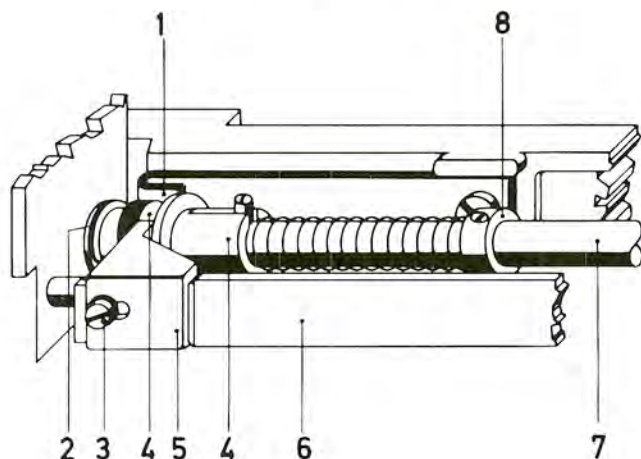
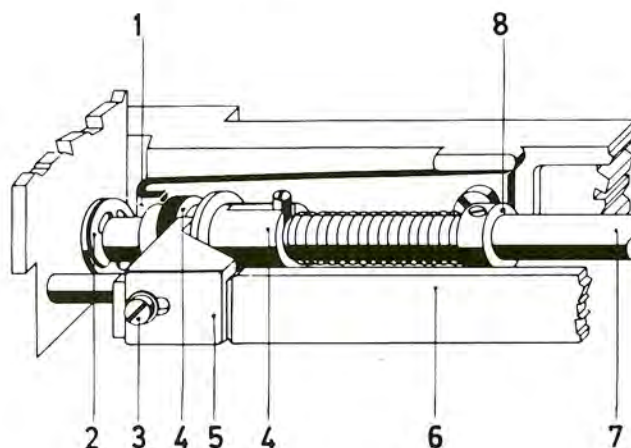

Fig. 26a



With the reverse-feed control turned to the darning position, there should be a clearance of 0.5 mm (.02") between the right edge of eccentric follower 1 and the left edge of feed lifting eccentric 4 (Fig. 26a). In this position of the machine, the eccentric follower rests on the hub of the feed lifting eccentric.

### Check:

Check if the setting is correct by operating the reverse-feed control and turning the balance wheel.

### Adjustment:

Turn the reverse-feed control over toward the left (darning position). Loosen screw 3 on regulating bracket 5 (Fig. 26a) and move the latter to the right or left until the clearance between the right edge of eccentric follower 1 and the left edge of feed lifting eccentric 4 is 0.5 mm. Then tighten screw securely again.

### Verification:

Check whether the above setting is correct by operating the reverse-feed control and turning the balance wheel.

## 27. Setting the Presser Bar at the Correct Height

Rule: ( old version )

On machines without top feed, there should be a clearance of 6.5 mm (abt. 1/4") between sewing foot and needle plate. On top-feed machines, this clearance should be 5.0 mm (abt. 3/16").

Note:

The difference in the above clearance is to be attributed to the fact that on top-feed machines the presser bar insert to which the sewing foot is attached is pushed down by 1.5 mm by a separate spring.

Fig. 27

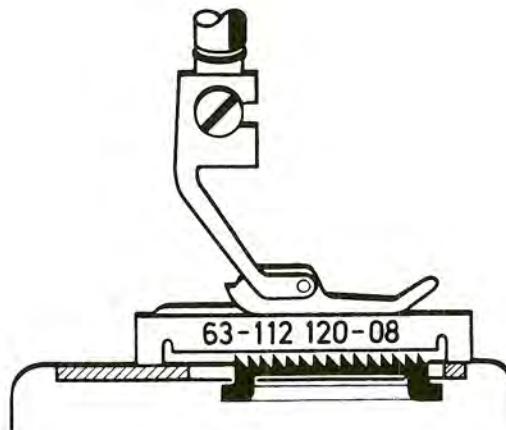

Check:

To check the amount of clearance between sewing foot and needle plate, use gauge No. 63-112 120-08 (Fig. 27), no matter whether the machine has top feed or not. When the presser bar lifter is raised, the sewing foot should rest on the gauge firmly. On top-feed machines, push the sewing foot and the insert to which it is attached up into the presser bar as far as it will go. With the sewing foot pushed up against its stop, there should be no clearance between its sole and the surface of the gauge.

Adjustment:

Remove the face cover and take out the sewlight socket screw to expose screw 9 in presser bar guide collar 8 (Fig. 27a). Raise the presser bar lifter and place the gauge under the sewing foot (Fig. 27a). Now loosen screw 9 in the presser bar guide collar and screw 11 in the block at the upper end of the presser bar. Push presser bar 10 with the sewing foot down onto the gauge. On top-feed machines, also push insert 7 up into the presser bar as far as it will go.

Push presser bar guide collar 8 downward and tighten its screw lightly. Remove the gauge and slowly lower the presser bar onto the needle plate. Turn the presser bar so that the needle slot in the sewing foot is in line with the needle and the needle plate slot. In addition, make sure the sewing foot parallels the edges of the feed slots.

**Verification:**

Having adjusted the sewing foot height with the aid of the gauge, securely tighten screw 9 in the presser bar guide collar.

Fig. 27a

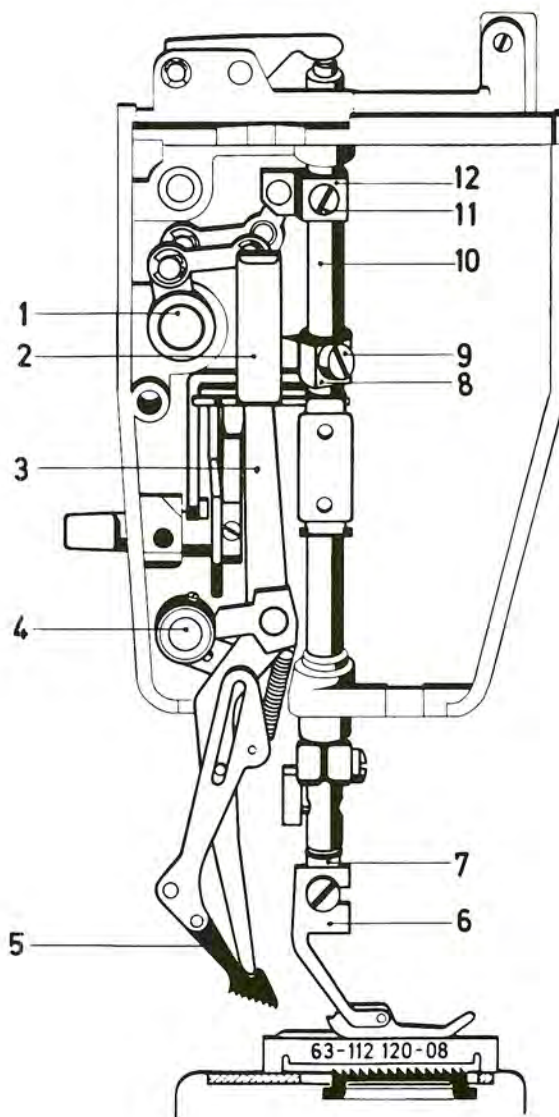



27a. New Height Setting for Presser Bar on Machines with Top Feed, from Machine No. 29 311 283 onwards

In order to increase the presser foot height on machines with top feed, a modified control rod link No. 93-040 538-11 was introduced from machine No. 29 311 283 onwards. The previous control rod link has become obsolete. If it is required to set machines of earlier numbers to the higher presser foot height, it is necessary to fit control rod link No. 93-040 538-11

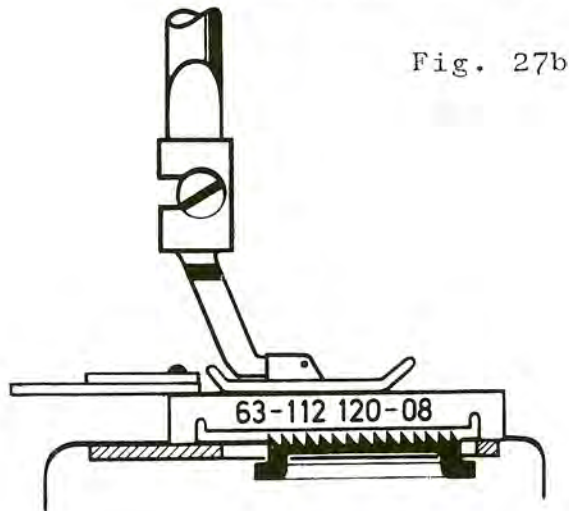

Fig. 27b

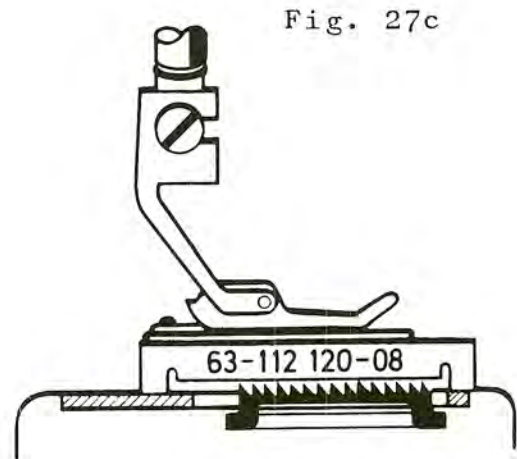

Fig. 27c

Rule: ( new version )

Machines without top feed have a presser foot height of 6.5 mm and are adjusted by means of universal feed height gauge No. 63-112 120-08 with the feeler gauge blade out (see Fig. 27b). Machines with top feed have a presser foot height of 7.5 mm and are adjusted with the same universal gauge, but with the feeler gauge blade in (see Fig. 27c).

Note 1:

The universal feed height gauge has a height of 7.5 mm with its feeler gauge blade in, and 6.5 mm with the blade out. On machines with top feed, the presser foot drops with its presser bar insert by 1.5 mm, which means that when the gauge is removed there is a final clearance of 6 mm.

Note 2:

All machines up to No. 29 311 283 must still be adjusted according to par. 27 without the 1 mm feeler gauge. For adjustment, remove the 1 mm feeler gauge and swing the blade for the top feed into position.

Check:

On machines without top feed, raise the presser bar lifter and insert the universal feed gauge under the presser foot with the feeler blade out (see Fig. 27b)

On machines with top feed, lift the presser bar and insert the universal gauge with the feeler blade in (see Fig. 27c).

In both cases there must be no play between the bottom of the presser foot and the universal feed gauge. The additional insert of the presser bar on machines with top feed must be pushed right up against its stop.

Adjustment:

Remove the face cover and take out the sewlight socket screw to expose screw 9 in presser bar guide collar 8 (Fig. 27d). Raise the presser bar lifter and place the gauge under the sewing foot (Fig. 27d). Now loosen screw 9 in the presser bar guide collar and screw 11 in the block at the upper end of the presser bar. Push presser bar 10 with the sewing foot down onto the gauge. On top-feed machines, also push insert 7 up into the presser bar as far as it will go. Push presser bar guide collar 8 downward and tighten its screw lightly. Remove the gauge and slowly lower the presser bar onto the needle plate. Turn the presser bar so that the needle slot in the sewing foot is in line with the needle and the needle plate slot. In addition, make sure the sewing foot parallels the edges of the feed slots.

Verification:

Having adjusted the sewing foot height with the aid of the gauge, securely tighten screw 9 in the presser bar guide collar.

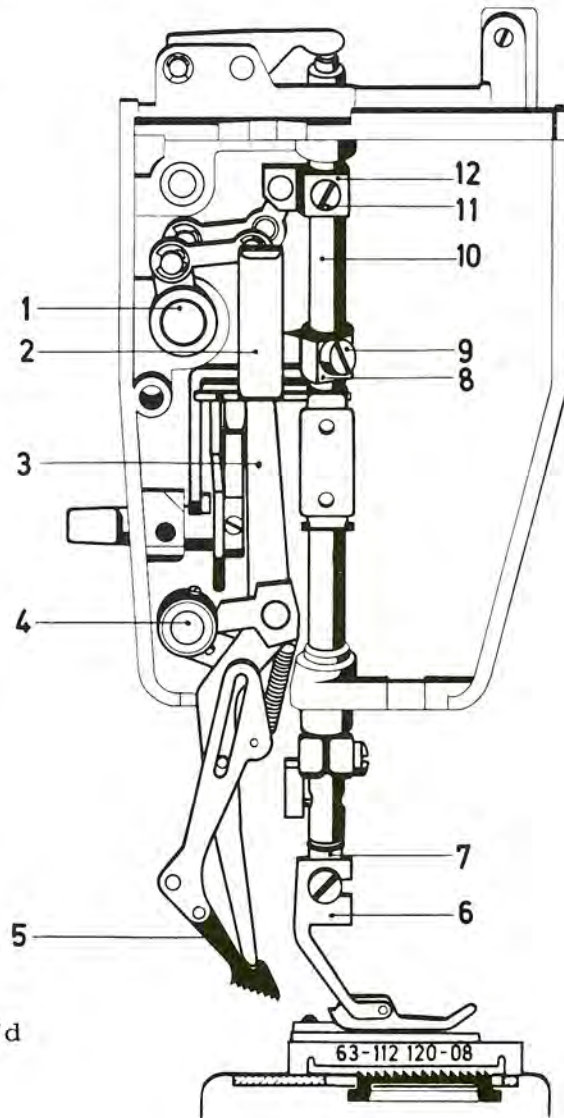

Fig. 27d

## 28. Adjusting the Pressure on the Material

### Rule:

For sewing ordinary materials, the lobe of the hexagonal eccentric stud 3 should point toward the rear wall of the machine arm (Fig. 28).

### Note:

For sewing delicate and flimsy materials, the pressure on the fabric may be eased; for heavy or dense materials, on the other hand, the pressure may be increased.

Fig. 28

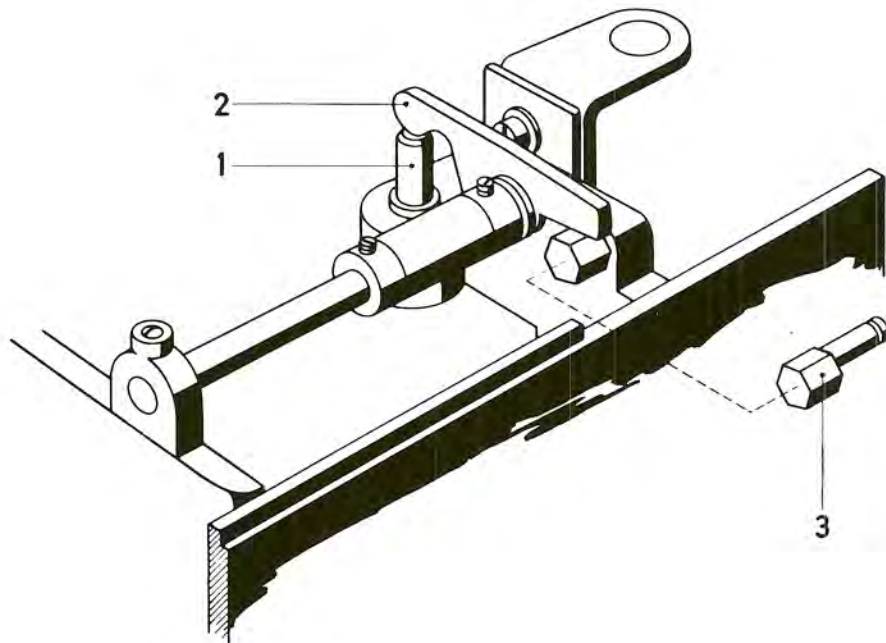

### Adjustment:

Lower the sewing foot and depress lever 2 and spring-loaded pin 1 (Fig. 28). Now eccentric stud 3 can be easily turned to the appropriate position.



29. Lateral Adjustment of Feeding Foot in Relation to Sewing Foot

Rule:

The feeding foot should roughly be centered in the cutout of the sewing foot (Fig. 29).

Note:

The feeding foot must be correctly adjusted when assembling the machine.

Adjustment:

If adjustment is required; strip the complete top feed mechanism and place spacing washers in suitable thickness on stud 4, depending on the position of the feeding foot in the cutout (Fig. 29a).

Fig. 29

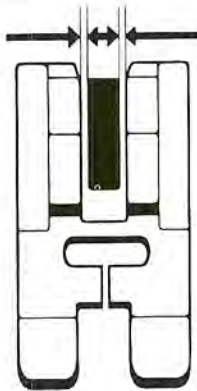

Spacing washers are available under the following part numbers:

|                   |               |
|-------------------|---------------|
| No. 92-203 077-05 | 0.5 mm thick  |
| No. 92-203 044-05 | 0.4 mm thick  |
| No. 92-203 676-05 | 0.3 mm thick  |
| No. 92-203 541-05 | 0.15 mm thick |

Fig. 29a

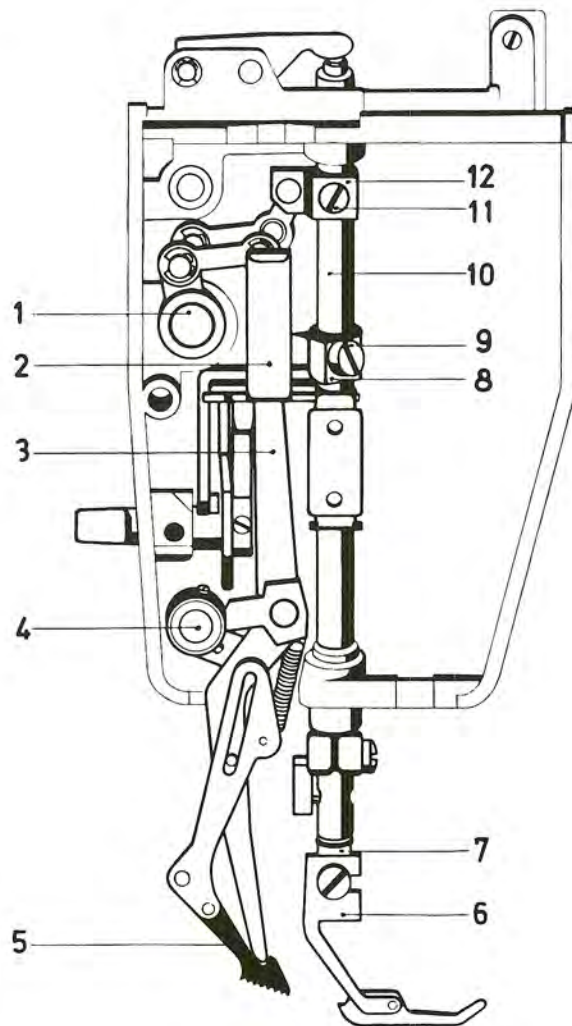

Replace the complete top feed mechanism. Loosen both collars 2 and 3 on top feed shaft 1 (Fig. 29b) and adjust the shaft endwise so that top feed lever 3 (Fig. 29a) does not bind. Tighten the screws in collars 2 and 3 (Fig. 29b), making sure that shaft 1 has no end play.

Fig. 29b

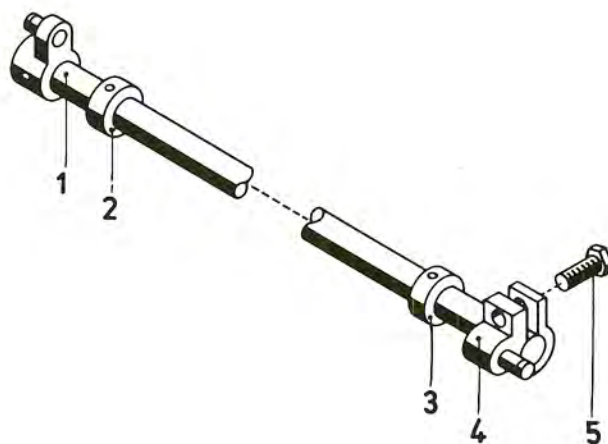

### 30. Adjusting the Feeding Foot in Sewing Direction

**Rule:**

The front edge of the feeding foot should be positioned above the first tooth of the central tooth row on the machine feed (Fig. 30).

**Check:**

Determine the correct position by a visual inspection.

Fig. 30

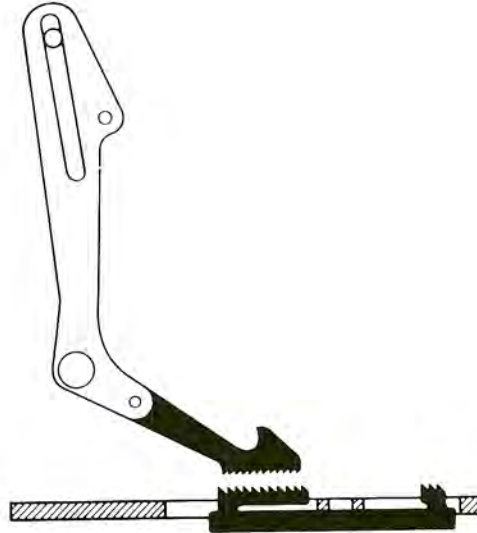

**Adjustment:**

Remove the top cover. Take a 7-mm spanner and slightly loosen hexagon screw 5 (Fig. 30a). Slightly raise the feeding foot and move it forward or backward until the above setting is correct (Fig. 30). Fully tighten hexagon screw 5 (Fig. 30a).

**Verification:**

Check to see if the front edge of the feeding foot is positioned exactly above the first tooth of the feed dog. Screw on the sewing foot. With the machine set for its longest stitch, there should now be a small clearance between the end of the slot in the sewing foot and the feeding foot when the latter is at the near end of its stroke.

Fig. 30a

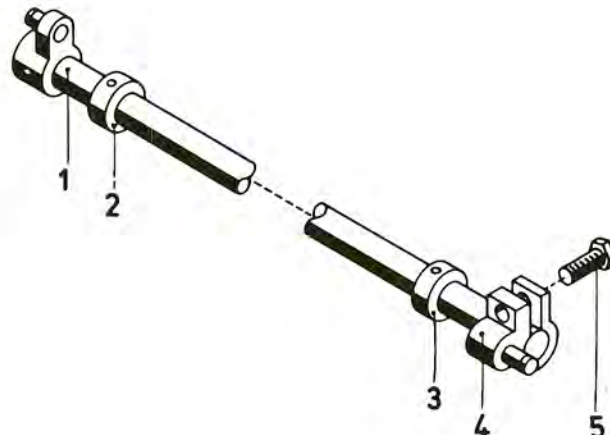



### 31. Adjusting the Feeding Foot Vertically

Rule: old version

When in its highest position, the feeding foot should have risen 1.2 mm (.05") above the sole of the sewing foot.

Check:

Raise the presser bar lifter and engage the top feed. Remove the needle and bring the needle bar to its lowest point. Raise the sewing foot as high as possible by its screw and push gauge No. 63-112 120-08 under it (Fig. 31). The feeding foot should now rest on the additional tongue of the gauge and the sewing foot on the gauge proper without having any play. Make sure that insert 7 of sewing foot 6 is up against the stop in presser bar 10. If the sewing foot insert does not bear against the stop of the presser bar or the feeding foot does not rest on the tongue of the gauge, the feeding foot height must be readjusted.

Adjustment:

Remove the face cover and the complete tension mechanism. Loosen screw 11 in block 12 and push the latter down lightly until the feeding foot rests firmly on the tongue of the gauge. Now tighten screw 11 in block 12 securely.

Verification:

Feeding foot and sewing foot should both rest firmly on the gauge. After removing the gauge and lowering the presser bar lifter, the feeding foot in its highest position should be positioned 1.2 mm above the sole of the sewing foot.

Fig. 31

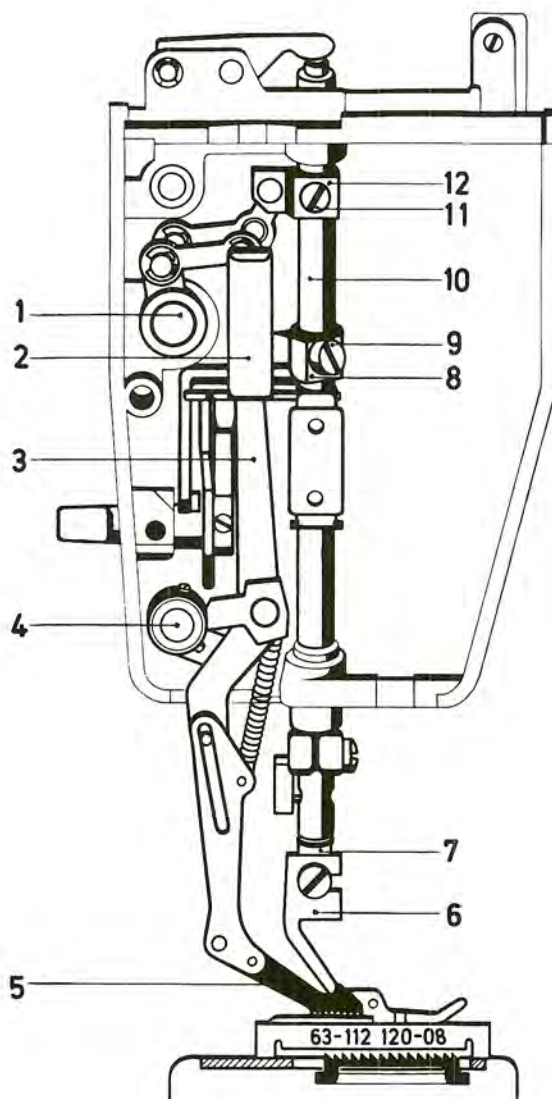

31a. Adjusting the Height of the Feeding Foot  
from Machine No. 29 311 283 onwards

Note:

From machine No. 29 311 283 onwards, the presser foot height for machines having top feed is 7.5 mm (see par. 41a). Due to this, the presser foot height on machines from the above-mentioned number onwards has to be adjusted with the additional 1-mm feeler gauge; on the machines having earlier numbers than this, adjustment is made without the 1-mm feeler gauge (see par. 31). To adjust, take out the 1-mm feeler gauge of feed height gauge No. 63-112 120-08 or insert it as the case may be.

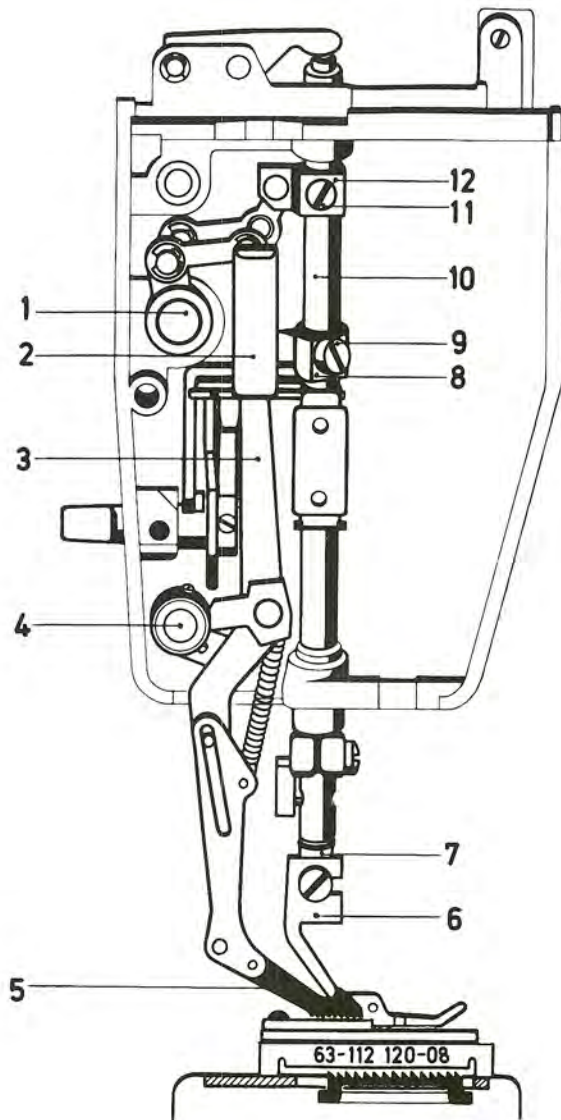

Fig. 31a



### 32. Adjusting the Vibrator

**Rule:**

When at its lowest point, the darning foot should be positioned 0 to 0.1 mm (.004") above the needle plate (Fig. 32).

**Check:**

Turn the reverse-feed control over to the left (darning position) and bring the darning foot to its lowest point. Check this setting visually.

**Note:**

Prerequisite for this adjustment is that both the sewing foot and the feeding foot are correctly adjusted vertically.

Adjustment procedure for top-feed machines:

Screw on darning foot 6 and rotate the balance wheel until the darning foot is at its lowest point (Fig. 32). Remove the top cover. Now turn screw 1 in lever 4 (Fig. 32a) in or out until the sole of the darning foot is 0 to 0.1 mm above the needle plate. The setting of lock nut 2 must not be disturbed in the process; it should be retained by lock washer 3.

**Verification:**

Place a single ply of fabric under the darning foot and run the machine. The darning foot should just touch the material.

Fig. 32

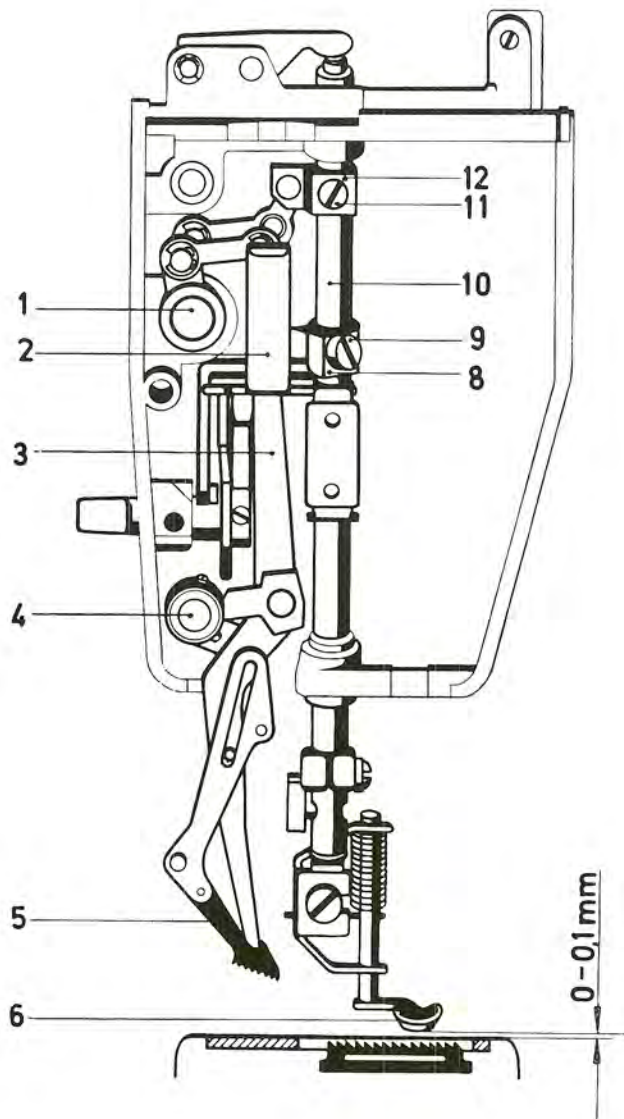
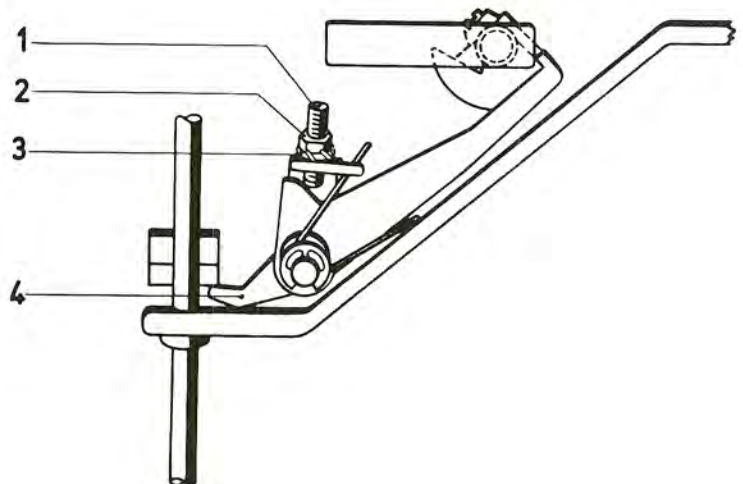

Fig. 32a





Adjustment procedure for ordinary-feed machines:

Screw on darning foot 6 and rotate the balance wheel until the darning foot is at its lowest point (Fig. 32b). Remove the face cover and the tension mechanism. Loosen screw 11 in block 12 so that presser bar 10 can slide downward. Raise the darning foot by its screw until its sole is 0 to 0.1 mm above the needle plate. At the same time push down block 12 and hold it there until you have tightened screw 11.

Verification:

Place a single ply of fabric under the darning foot and run the machine. The darning foot should just touch the material.

Fig. 32b

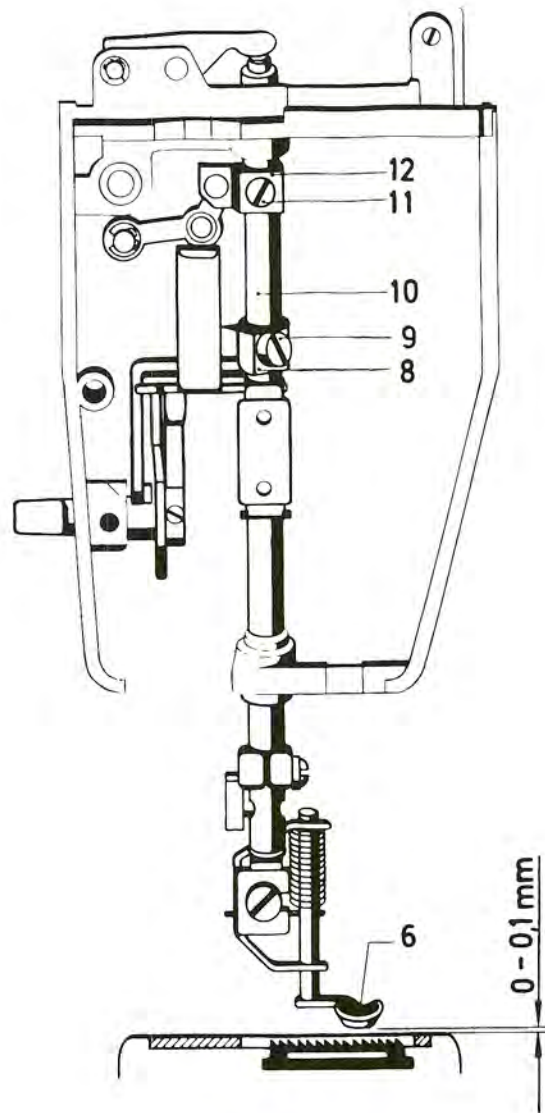

### 33. Timing the Buttonhole Forward-Reverse Feed

#### Rule:

There should be no play between cam follower 2 and cam 1 as well as lever 6 and bellcrank 7 when the reverse-feed control points upward and the buttonhole mechanism is switched to reverse sewing (Fig. 33).

#### Check:

Turn the reverse-feed control to its vertical position and the master selector dial to the buttonhole position. Remove the arm standard cover below the balance wheel. Let the machine run slowly. Depress the buttonhole control, then release it again. Stop the machine with the buttonhole mechanism in this position. Take a screwdriver and push against lug 4 of lever 6 (Fig. 33) to check if cam follower 2 and lever 6 have any play.

Fig. 33

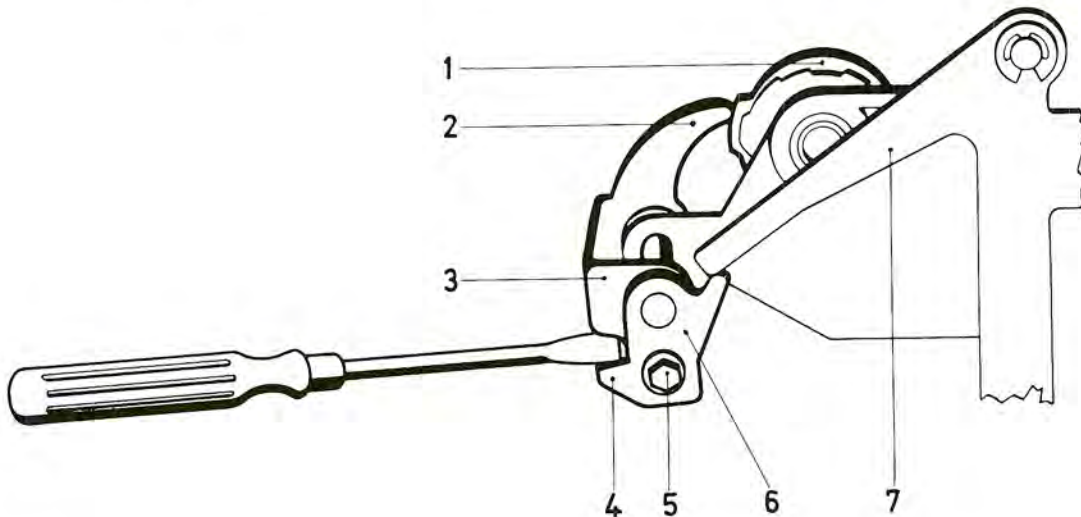

#### Adjustment:

If there is any play left between the cam follower and the lever, loosen hexagon screw 5 just lightly, using a 5.5-mm spanner. Insert a screwdriver between lug 4 of lever 6 and ear 3 of cam follower 2 and press both parts apart lightly until they have no play any more. In this position, securely tighten hexagon screw 5.

#### Verification:

Check the levers for play. Let the machine run slowly. Operate the buttonhole control to simulate a complete buttonhole sewing cycle and watch the switching over of the clutch sleeve and of the feed eccentric from forward to reverse sewing.

## SEWING MECHANISM

Adjustment of the sewing hook is carried out in three steps, as follows:

- adjusting the needle bar rise (or timing the sewing hook),
- setting the needle bar at the correct height, and
- setting the hook-to-needle clearance.

Adjusting the needle bar rise:

The needle bar rise is the distance the needle bar has to move upwards after it has passed the bottom of its stroke until a thread loop is formed on the short-groove side of the needle (Fig. 34).

When the needle bar is at this point, the point of the sewing hook should be exactly opposite the center line of the needle. When the balance wheel is now turned, the hook point should enter the loop, enlarge it and pass it around the bobbin case.

Setting the needle bar at the correct height:

The needle bar must be positioned vertically so that the hook point readily enters the needle thread loop at a point above the needle eye, regardless whether the machine is set for straight-stitch or zigzag sewing.

Setting the hook-to-needle clearance:

The sewing hook should be set as close to the needle as possible so that its point does not miss the thread loop.

Fig. 34

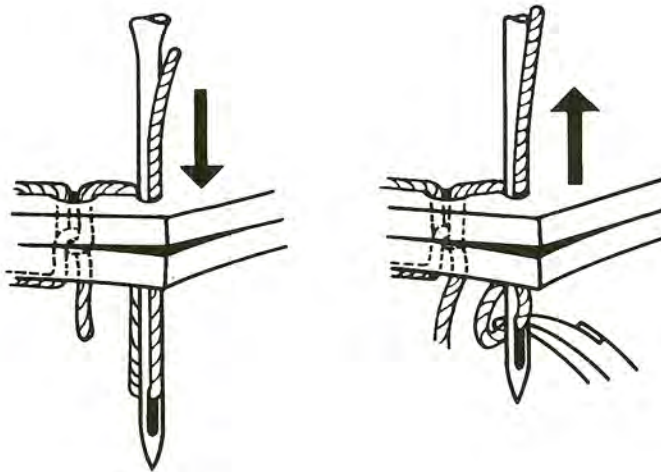

To adjust the sewing hook, proceed as follows:

- (1) adjust needle bar rise
- (2) set needle bar at correct height
- (3) set hook-to-needle clearance



### 34 a. Revised position of the needle in the needle plate slot

#### Rule:

There should be a clearance of 0,2 mm between the back of the needle shaft and the back of the needle plate slot (see Fig.34b). As an increase in needle size is always towards the front, the point of a No. 100 needle would be positioned exactly in the center of the needle plate slot, while that of a No. 80 needle would be positioned in the back third of the slot.

#### Check:

Insert a new system 130/705 H needle in size 100, and rotate the balance wheel until the needle is positioned in the needle plate slot. Now check whether the needle is centered in the needle slot in the sewing foot and the needle plate in sewing direction and whether there is a clearance of 0,2 mm between its rear edge and the rear edge of both needle slots.

#### Adjustment on free-arm machines:

If adjustment is required, loosen screw 2 (Fig. 34b), and move stud 5 together with needle bar frame 4 until the needle is correctly centered in the needle plate slot in sewing direction. Then, tighten screw 2 securely again.

#### Adjustment on flatbed machines:

If adjustment is required, loosen screw 2 (Fig. 34b), and move stud 5 together with needle bar frame 4 until the needle is centered correctly in the needle slot of zigzag foot 17 in sewing direction. Then tighten screw 2 securely. Unscrew the sewing foot. Move both screws of the needle plate bracket together with needle plate 15, until the needle is centered correctly in the needle slot of needle plate 15 in sewing direction. Securely tighten the two screws of the needle plate bracket.

#### Verification:

Check by sight to make sure that the center position of the needle is maintained at various needle bar heights. Furthermore, there should be a clearance of 0,2 mm between the back of the needle shaft and the needle plate slot. Turn the master selector dial to stitch range 8 and rotate the balance wheel until the needle is on the left of its throw. Now press needle bar 14 to the right. It should spring back into place freely.

### 35. Basic Position of Hook Bearing

To facilitate adjustment of the sewing hook, the bearing of the hook drive shaft should be at an angle of 90 degrees to the needle bar.

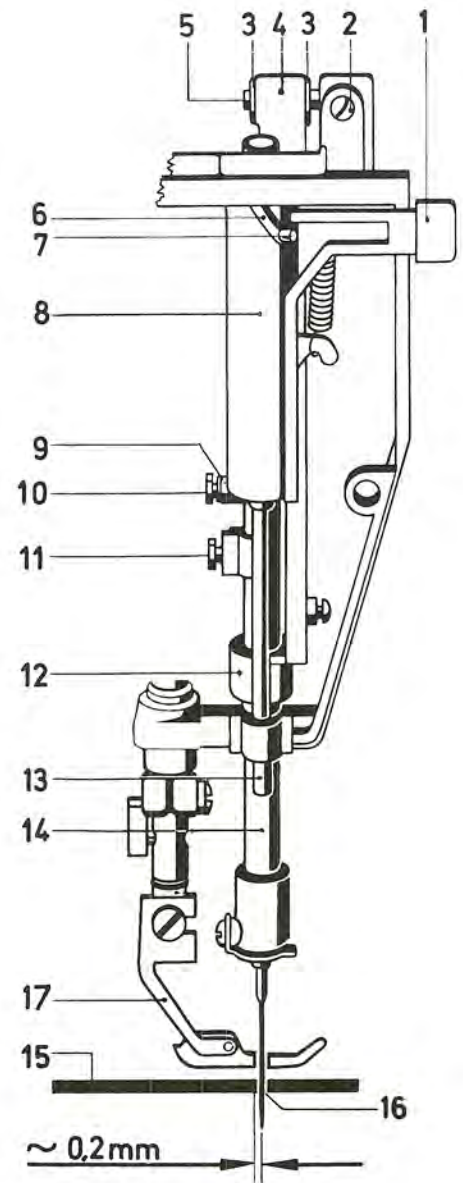

Fig. 34b

### 36. Timing the Sewing Hook

#### Rule:

When the machine is set for straight stitching in the central needle position, and the needle has risen 2 mm (5/64") from the bottom of its stroke, the point of the sewing hook should be exactly opposite the center line of the needle at the back.

#### Check:

Turn the master selector dial to straight stitching and the needle position knob to the central needle position. On machines fitted with automatic mechanism, erase all stitch settings. In order to obtain a better view, remove the sewing foot and the needle plate. Take out both screws of the bobbin case position finger bracket and dismantle the sewing hook. Insert a new System 130 needle in size 80 and bring the needle to the bottom of its stroke by turning the balance wheel (Fig. 36). Attach the C-clamp (No. 870-137-00) lightly to the needle bar. Push the 2-mm gauge (No. 870-136-00) with its cutout onto the needle bar above the C-clamp. Now push C-clamp and gauge upwards against the needle bar frame as far as possible. Then tighten the screw of the C-clamp securely. Turn the balance wheel back and forth slightly in order to check if the needle bar is really at its lowest point. There must be no play between needle bar frame, gauge and C-clamp (Fig. 36). Remove the gauge and rotate the balance wheel in sewing direction until the C-clamp is in contact with the needle bar frame (Fig. 36a). The needle bar has thus risen by 2 mm which is the amount of needle rise required to form the loop. The hook point must now be exactly opposite the center line of the needle at the back.

Fig. 36

Fig. 36a

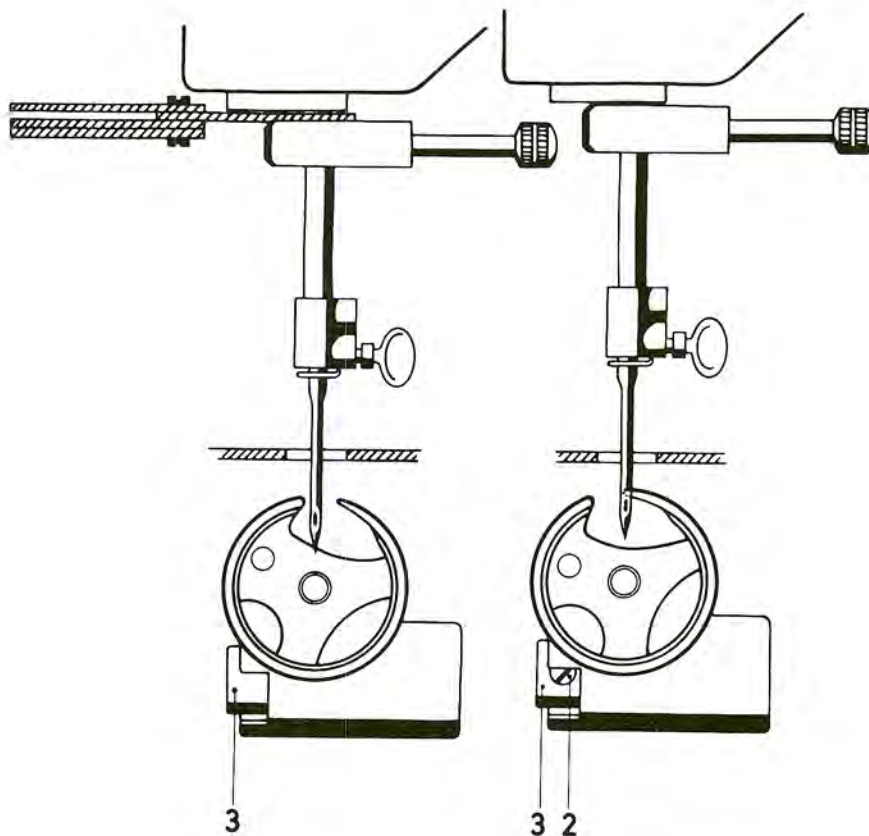



**Adjustment:**

If the sewing hook is completely out of adjustment, remove the hook bearing cover and loosen both screws 2 of helical gear 3 (Fig. 36a). For this, loosen the C-clamp and repeat the adjustment described under "Check". Turn the sewing hook until its point is exactly opposite the center line of the needle at the back (Figs. 36a and 36b). With the sewing hook in this position, push helical gear 3 to the right and press it lightly against the bearing. Securely tighten screws 2.

**Note:**

If no screw is visible when the helical gear is in the above position, pull helical gear 3 out and insert it again so that one of its screws accessible.

Fig. 36b

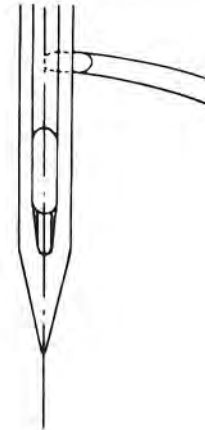

**Verification:**

Turn the balance wheel backward a little and then forward until the C-clamp is again in contact with the needle bar frame. The point of the sewing hook must now be exactly opposite the center line of the needle at the back.

Now remove the C-clamp. Fully tighten both screws 2 of helical gear 3. Make sure that the hook drive shaft does not bind.

37. Setting the Needle Bar at the Correct Height

The machine is equipped with a transverse, double-revolution rotary hook. When the needle descends on the right of its throw in zigzag sewing, the hook point reaches the needle a little earlier: when it descends on the left of its throw, a little later. Consequently, the hook point is a little higher above the needle eye when the needle is on the right of its throw than when it descends on the left of its throw (Fig. 37).

LMR

Fig. 37

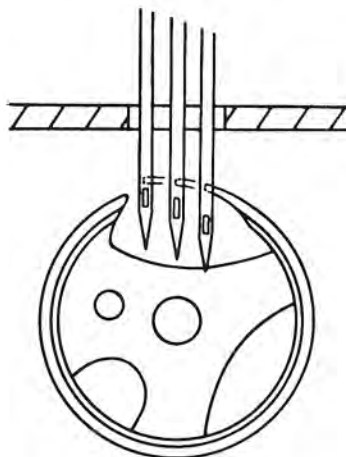



Rule:

When the machine is set for its widest zigzag stitch and the needle descends on the left of its throw, there should be a clearance of 0.5 mm (.02") between the top of the needle eye and the lower edge of the hook point (Figs. 37a and 37b).

Fig. 37a

Fig. 37b

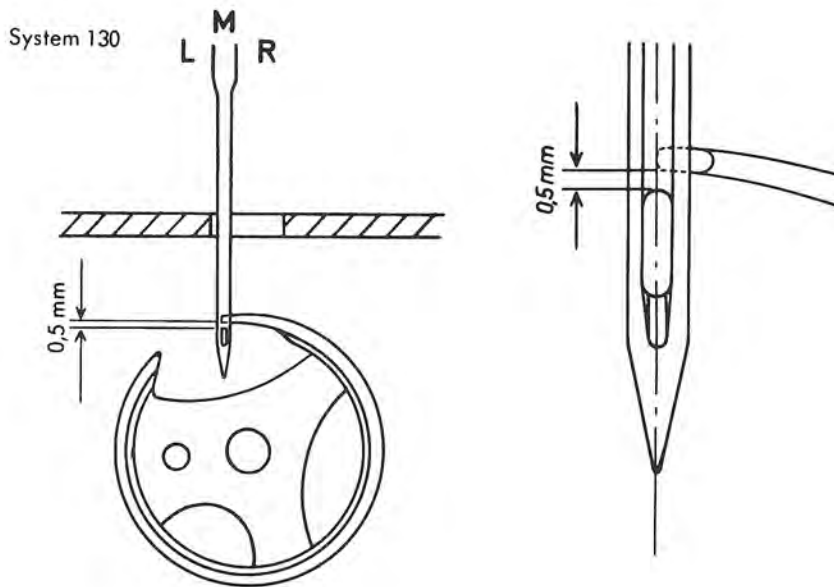

Check:

Turn the master selector dial to stitch range 8 and the needle position knob to the central needle position. On machines fitted with automatic mechanism, erase all stitch settings. Remove the sewing foot and the needle plate. In order to obtain a better view, loosen both screws of the bobbin case position finger bracket and dismantle the sewing hook. Rotate the balance wheel in sewing direction until the needle descends on the left of its throw. Then continue turning the balance wheel until the needle rises again and the hook point is exactly opposite its center line at the back. The clearance between the top of the needle eye and the underside of the hook point should now be 0.5 mm (.02"), as illustrated in Figs. 37a and 37b).

**Adjustment:**

If this clearance is incorrect, remove the face cover and slightly loosen hexagon screw 11 (Fig. 37c), using a 5.5-mm spanner. Position needle bar 14 at the correct height, making sure that you do not turn it. Then lightly tighten hexagon screw 11 again.

**Verification:**

After sight-checking the needle bar height and the correct angle of the needle holder, tighten hexagon screw 11 securely.

Fig. 37c

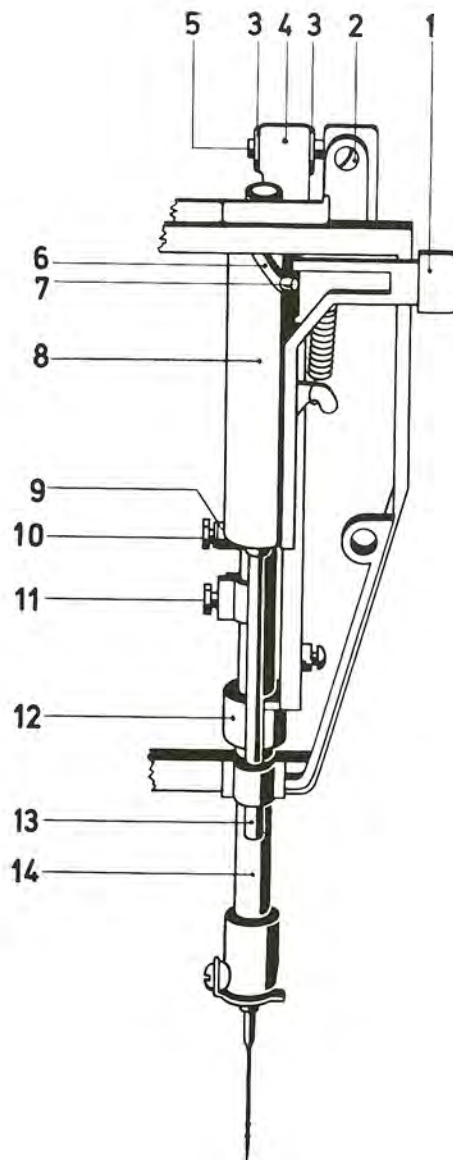

### 38. Setting the Hook-to-Needle Clearance

With the machine set for straight stitching, the clearance between the hook point and the bottom of the clearance out of the needle should be 0,05 mm (.004"), as shown in Fig. 38. At the widest zigzag-stitch setting, the hook point should almost touch the needle as it descends on the right and left of its throw.

Fig. 38

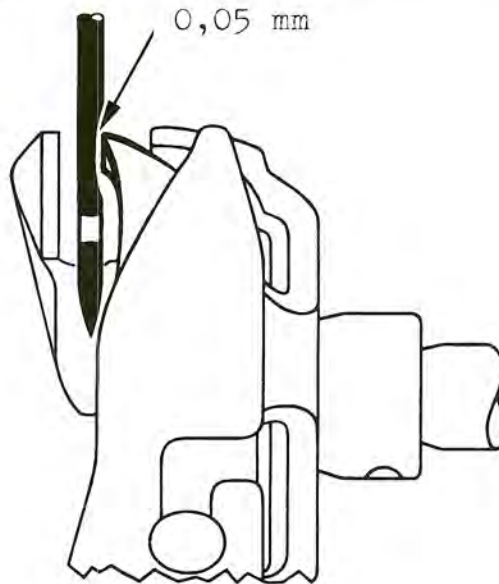

#### Check:

Remove the sewing foot and the needle plate. Loosen both screws of the bobbin case position finger bracket and strip the sewing hook. Insert a new System 130 needle, No. 80, and check the above clearance with the machine set for straight stitching and the widest zigzag stitch.

#### Adjustment:

If the clearance between sewing hook and needle has to be set a new, loosen hook bearing screw 1 (Fig. 38a). On free-arm machines, the base plate and the free arm bottom cover must be removed first. Position the sewing hook so that the above clearance is correct, taking care however that hook bearing 2 is not pushed to the left and the feed rock shaft has no end play. Then tighten hook bearing screw 1 securely, but make sure that the feed rock shaft does not bind.



Fig. 38a

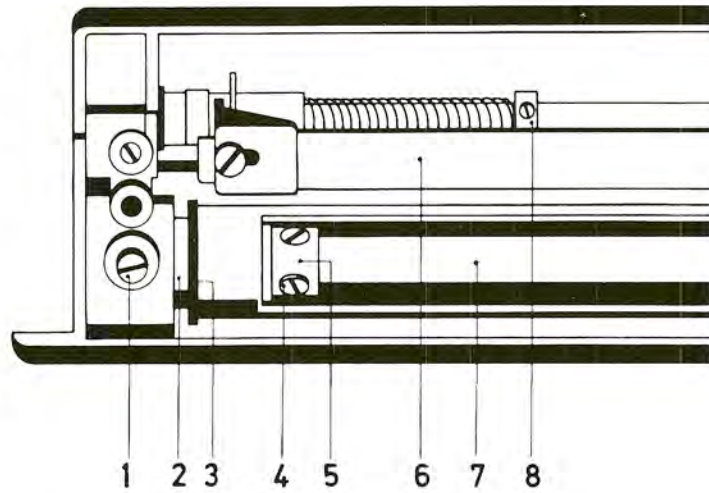

Verification:

Make a sight check to ascertain if the clearance is correct in straight and zigzag stitching.

39. Adjusting the Bobbin Case Position Finger

Rule:

There should be a clearance of 0.7 mm (.03") between the position finger and the bottom of the slot in the bobbin case base.

Check:

The gauge should pass freely, but without play, between the position finger and the wall of the position slot in the bobbin case base (Fig. 39).

Fig. 39

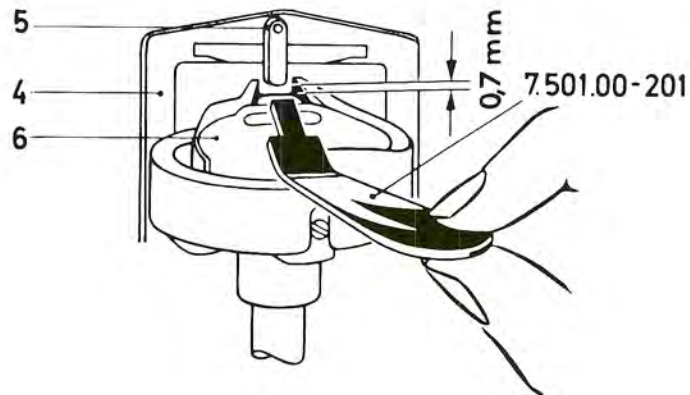

Adjustment:

Remove sewing foot and needle plate. On flatbed machines, the needle plate mounting bracket also has to be removed. Loosen both screws 1 of position finger bracket 4 (Fig. 39a). Insert the gauge between position finger 5 and the wall of the position slot in bobbin case base 6 (Fig. 39) and press position finger bracket 4 against the gauge at an angle of 90 degrees. Then tighten screws 1 again securely.

Verification:

See "Check" above.

Fig. 39a

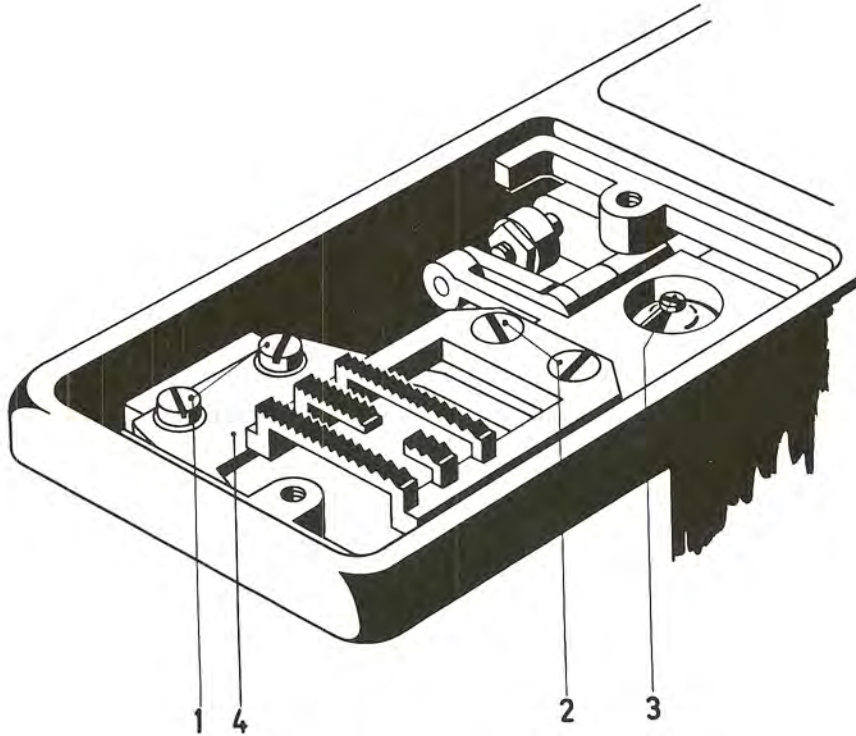

AUTOMATIC MECHANISM

40. Operation

Pfaff machines 1222 and 1221 are equipped with a combined functional and decorative-stitch mechanism. The functional-stitch mechanism is an automatic unit incorporating forward-reverse feed control and working at a fixed ratio, while the decorative-stitch mechanism is an automatic unit working at a variable ratio. Both automatic mechanisms are combined and incorporated in a joint automatic housing. Pfaff machines 1212 and 1211, on the other hand, are only equipped with a fixed-ratio functional-stitch mechanism.

Fig. 40

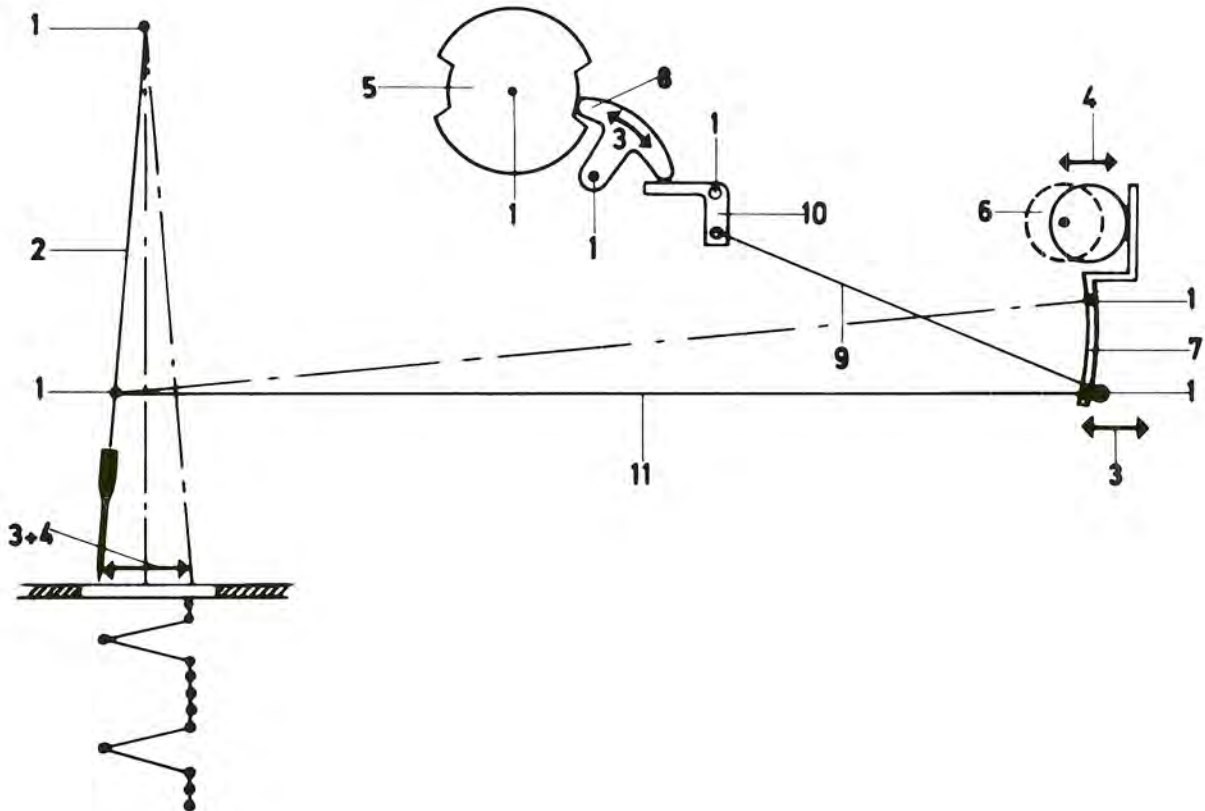



Fixed-Ratio Automatic Mechanism

The directly controlled automatic functional-stitch mechanism has a fixed reduction ratio of 12:1. Cam stack 5 with worm wheel (Fig. 40) is driven by a worm on the arm shaft. This worm also serves as a fixing collar for the arm shaft. Feeler fingers 8 which transmit motions 3 of the cams are connected to pivoted push-button levers which can be engaged or disengaged. When a push-button lever is depressed, feeler finger 8, which is a two-armed lever, contacts cam 5 on the one side and the lever of pivot sleeve 10 on the other. This pivot sleeve transmits motion 3 by way of linkage 9 to the needle position assembly of the zigzag mechanism. From here, motion 3 is transmitted by means of the long connecting rod 11 to needle bar frame 2.

Forward-reverse feed control:

The motions for changing from forward to reverse feed and vice versa also originate from cam stack 5 of the fixed-ratio automatic mechanism (Fig. 40a). These motions are transmitted by similar feeler fingers 8, which are also connected to the push-button levers. From here, motion is transmitted by means of feeler 10 which is firmly screwed to the above-mentioned pivot sleeve. This sleeve then transmits the motion by means of linkage 9 to link-type feed regulator 4 which, in turn, changes the direction of feed from forward to reverse and vice versa.

Fig. 40a

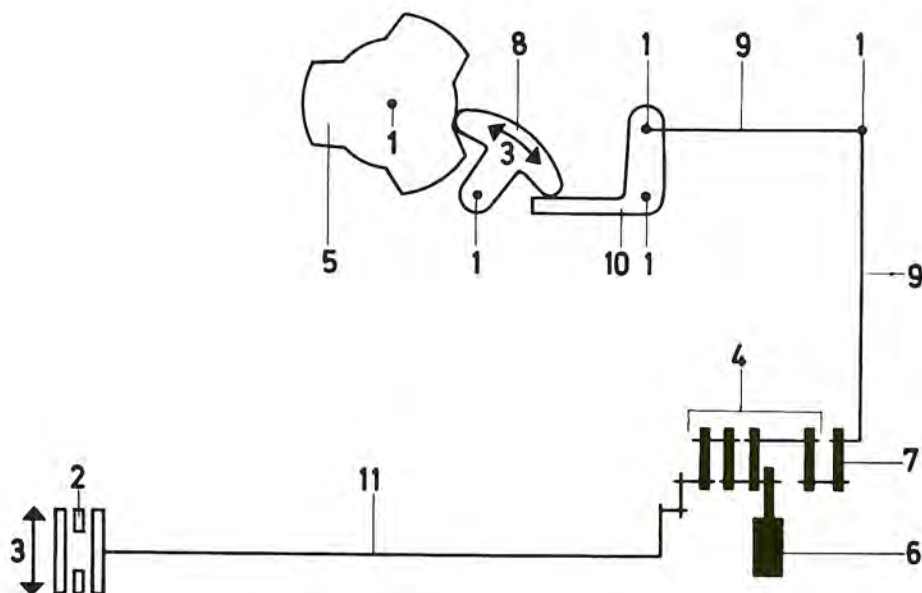

Variable-Ratio Automatic Mechanism

The indirectly controlled decorative-stitch mechanism has a variable reduction ratio so that it is possible to vary the length of the fancy-stitch pattern while retaining the stitch density. Its drive is taken from an eccentric on the arm shaft and transmitted to a drive lever which, depending on the position of the drive link, transmits a small, medium or large throw, or no throw whatever, to the roller clutch. The throw of the eccentric is only transmitted when the needle is out of the goods. While the drive link is moving back, the cam stack is retained by a pawl. This results in an intermittent revolving motion.

Fig. 40b

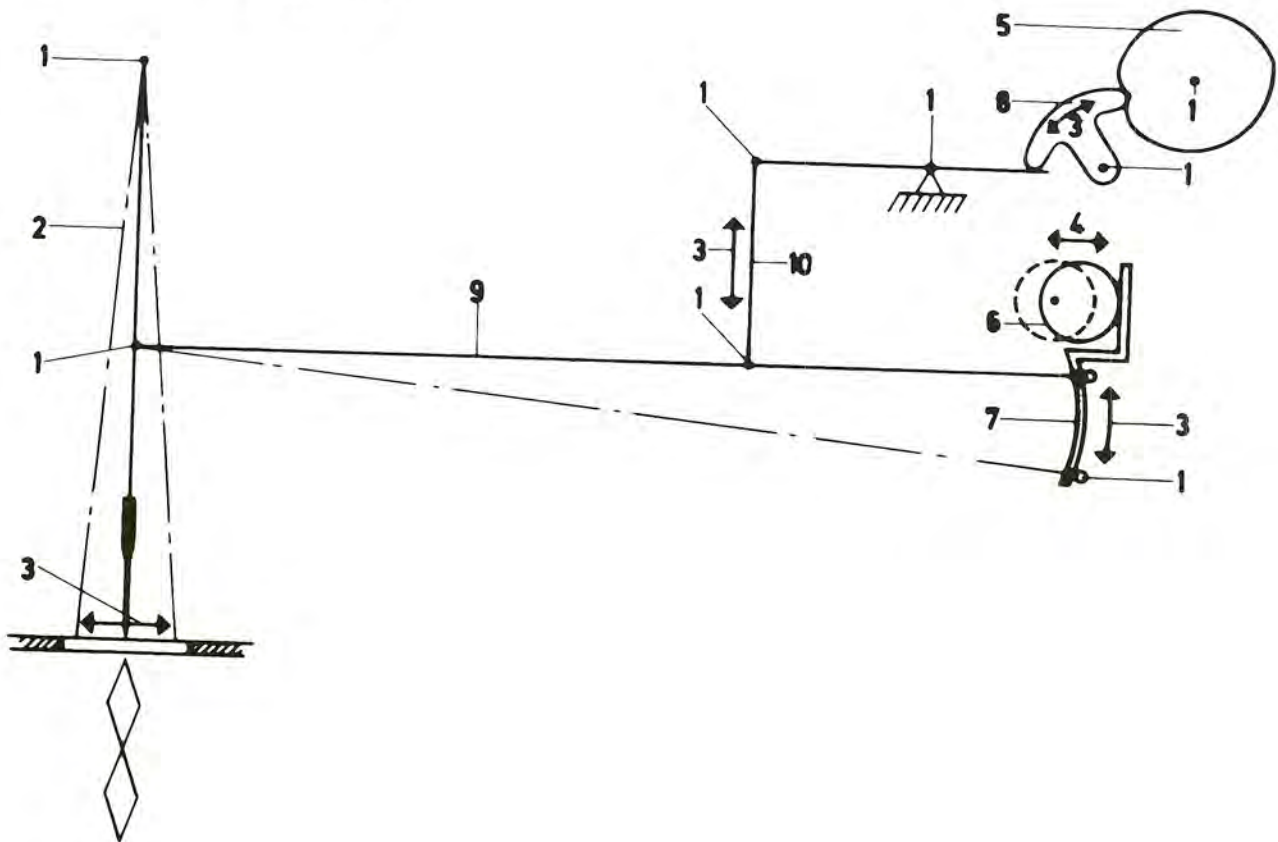

Feeler fingers 8 which take over motions 3 from cams 5 are connected to pivoted push-button levers which can be engaged or disengaged (Fig. 40b), the mechanical principle being the same as that incorporated in the fixed-ratio automatic unit.

When a push-button lever is depressed, feeler finger 8, which is a two-armed lever, contacts cam 5 on the one side and a lever on the other which is screwed to a fulcrum stud (Fig. 40b). A fulcrum lever, which is firmly connected to this stud, transmits the motion by way of connecting link 10 to the long connecting rod 9, thus causing the latter to move up and down. This changes the position of the roller on the long connecting rod in relation to needle vibrating lever 7. These positions range from pivot 1 of needle vibrating lever 7 to its maximum throw. According to the position of the roller, a greater or smaller zigzag throw 4 is transmitted to needle bar frame 2. By changing the needle position to the right or left, the resulting zigzag stitches or automatically produced patterns can be positioned to one side so that an unsymmetrical effect is produced.

The only exception is the motion required for producing scallop stitching. This motion is transmitted by means of a feeler to the pivot sleeve of the functional-stitch mechanism and from there to the needle position assembly. For scalloping, the stitch width is controlled in the same way as for all other fancy stitches.

#### 41. Fitting the Automatic Mechanism

##### Note:

A blind stitch normally consists of five straight stitches and a zigzag stitch. In order to produce a blind stitch which has additional small zigzag stitches, it is necessary that the throws originating from the zigzag eccentric and the cam of the fixed-ratio automatic mechanism, respectively, go in the same direction at the same time.

##### Fitting:

Turn the master selector dial to stitch range 8 and the needle position knob to the left needle position. Turn the balance wheel in sewing direction until the point of the needle ascending on the left of its throw is flush with the needle plate surface. Then turn the master selector dial to straight stitching.

Press the blind-stitch button and set the pattern length to 10. Turn the cam stack counter-clockwise until the feeler lever, pushed against the cam by a screwdriver, is exactly at the lowest point of the rising cam. Apart from this, all feeler levers must be up, i.e. so that they will contact their respective cams when engaged.



Fig. 41

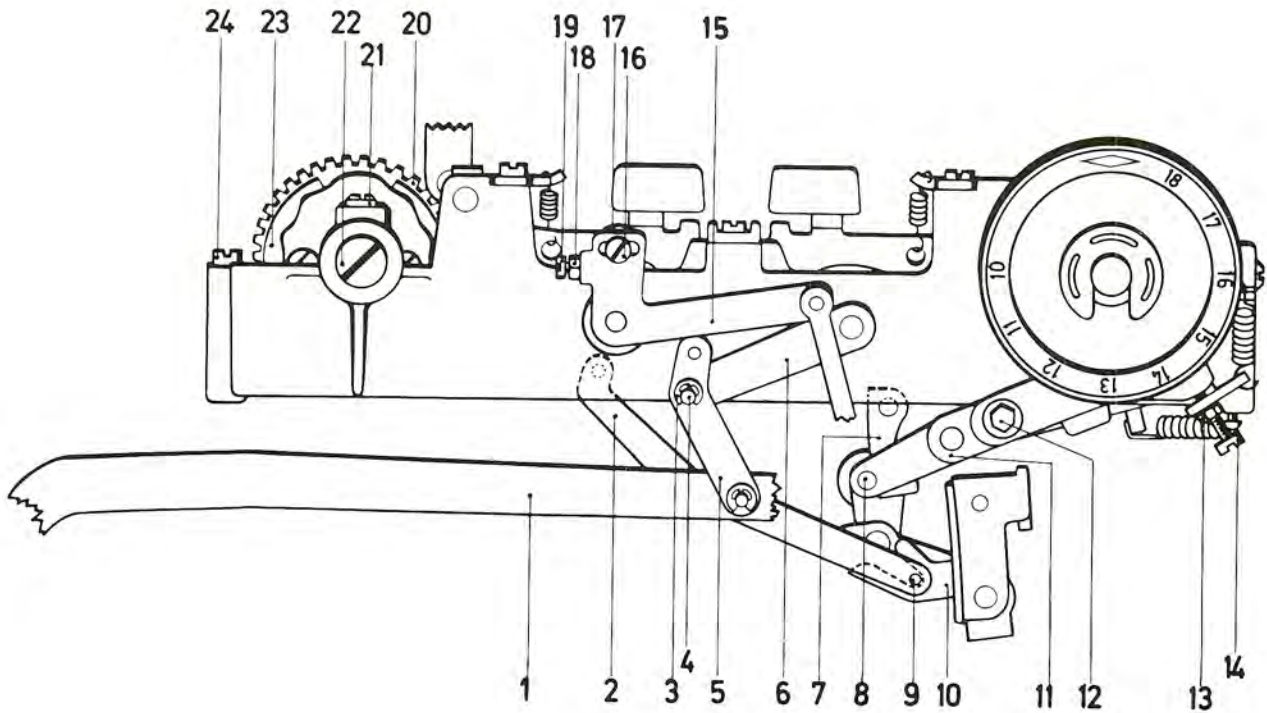

When in this position, the automatic mechanism can now be inserted into the machine after it has been set as described previously. When installing the automatic mechanism, care must be taken that

- a. the long connecting link 2 is inserted in fork 10 (Fig. 41),
- b. pin 8 of drive link 11 is positioned to the left of drive lever 7,
- c. fulcrum lever 5 is pushed on pin 4 of lever 6 and held in place by slip washer 3, and
- d. bellcrank 15, which controls forward and reverse stitching, is screwed onto lever 17.

On Pfaff machines 1212 and 1211, fulcrum lever 5 need not be pushed onto the pin of lever 6.

When all these points have been carefully checked, the automatic unit is screwed on with four screws.

Fixed-Ratio Automatic Mechanism

42. Setting the Clearance between Worm and Worm Wheel

Rule:

There must be no play between worm 12 and worm wheel 1 (Fig. 42), but it should be possible to turn the machine freely. The individual feeler fingers must contact their own cams only and not any of the other cams.

Check:

Press the cancelling button so that all feeler fingers are disengaged. Check for play by pushing the cam stack back and forth.

Fig. 42

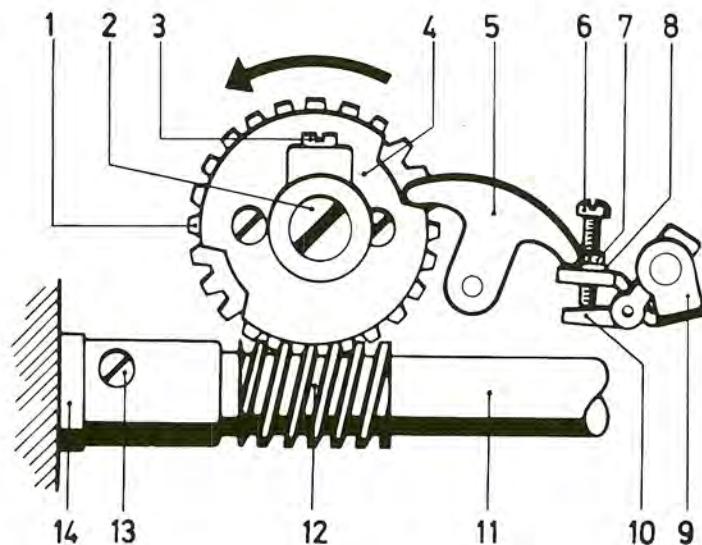

Adjustment:

Loosen screw 3, insert special adjusting tool (No. 106 300-306) in the slot of eccentric stud 2 and turn it counter-clockwise until there is no more play between worm 12 and worm wheel 1. At the same time, push cam stack 4 to the front or back until all feeler fingers 5 are resting on their respective cams only. Then tighten screw 3 securely.

Verification:

Check the machine for free rotation by turning the balance wheel. Furthermore, lightly push the cam stack back and forth in various positions of the balance wheel to make sure that there is no play between worm and worm wheel.

### 43. Setting the Feeler Fingers Close to the Cam Stack

**Rule:**

The feeler fingers must be set close to the cams on the one side and to the fork of the needle position lever on the other (Fig. 43).

**Note:**

This requirement must be met in order to carry out the following adjustments correctly:

Fig. 43

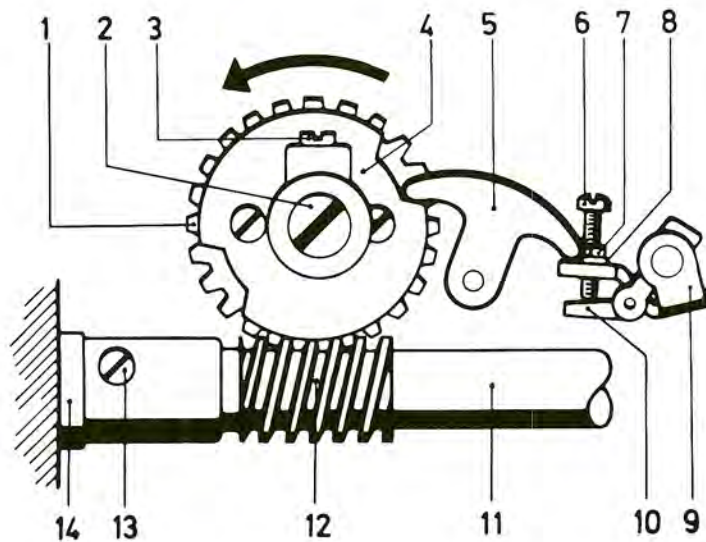

**Check:**

Set the master selector dial to straight stitching and turn the needle position knob to its left position. Press the blind-stitch button. Rotate the balance wheel until feeler finger 5 is in the middle of the recess on cam 4. Push against the right and left ends of the feeler finger with a screwdriver in order to check for play.

**Adjustment:**

Turn regulating screw 6 clockwise until there is no more play between the feeler finger and the cam on the one hand, and the feeler finger and lever 10 of pivot sleeve 9 on the other.



#### 44. Adjusting the Needle Vibrating Controlled by the Fixed-Ratio Automatic Mechanism

As with the zigzag mechanism, the needle should start swinging sideways after it has risen clear of the thickest material normally sewn on this machine. The sideways motion of the needle is controlled by the cams of the fixed-ratio automatic mechanism.

##### Rule:

The sideways motion of the needle should commence when its point has just left the needle plate slot and should be completed before the needle enters the fabric again, i.e. when its point has reached a position about 7 mm (9/32") above the needle plate (Fig. 44). In addition, the throws for the needle vibration emanating from the zigzag mechanism and the fixed-ratio automatic mechanism must be coordinated so as to go in the same direction at the same time.

Fig. 44

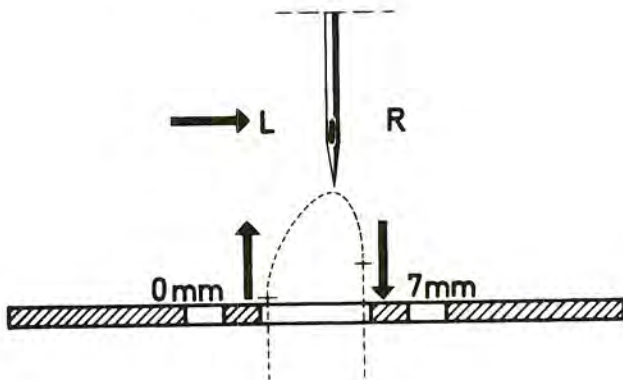
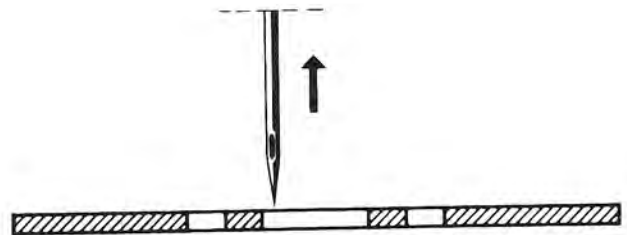

Fig. 44a



##### Check:

Turn the master selector dial to straight stitching and the needle position knob to its left position. Press the blind-stitch button. Rotate the balance wheel in its normal direction of rotation until the point of the needle ascending on the left of its throw is flush with the surface of the needle plate (Fig. 44a). Place your left forefinger against the needle bar frame and the arm casting. When rotating the balance wheel slowly, you can tell exactly when the sideways motion of the needle begins.

##### Adjustment:

Set the master selector dial to stitch range 8 and the needle position knob to its left position. Press the blind-stitch button. Rotate the balance wheel in sewing direction until the point of the needle rising on the left of its throw is flush with the needle plate surface (Fig. 44a) and feeler finger 5 (Fig. 44b) either drops into the recess of cam 4 or is very close to it (Fig. 44b).

Loosen the two screws 13 of worm 12. As you do this, make sure the needle stays on the left of its throw. Rotate the balance wheel until the point of the needle rising on the left of its throw is flush with the needle plate surface (Fig. 44a). Turn the master selector dial to straight stitching. Turn worm 12 until feeler finger 5 is exactly at the beginning of the rising portion of the rim of cam 4 (Fig. 44b). Hold the cam stack in this position and tighten one of the screws 13, but make sure arm shaft 11 has no end play.

Fig. 44b

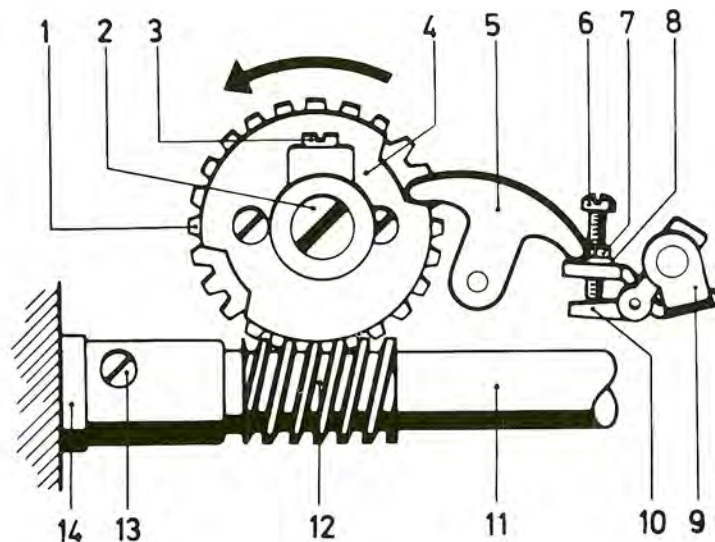

Verification:

Check the sideways needle motion as instructed under "Check" above. The arm shaft should neither have end play nor bind. Tighten the three screws 13 of the worm very securely. Check the blind stitch with additional zigzag stitches 2 to 2.5 mm (.07" to .09") wide. To do this, set the master selector dial to stitch range 6 or 9 and rotate the balance wheel. If the left throw of the needle diminishes and zigzag-stitch motions cancel each other out, this means that the motions originating from the zigzag eccentric and the cam are working against each other. In this case, the foregoing adjustment must be repeated. Make sure that the motions emanating from the zigzag eccentric and the cam act in the same direction.

45. Centering the Needle Throw in the Needle Plate Slot for Functional Stitching

Rule:

With the needle position knob turned to its left position and the machine set for functional stitching, the needle should clear both ends of the needle plate slot at the same distance when descending on the right and left of its throw (approx. 4-mm, or 5/32", stitch width), as shown in Fig. 45.

Fig. 45

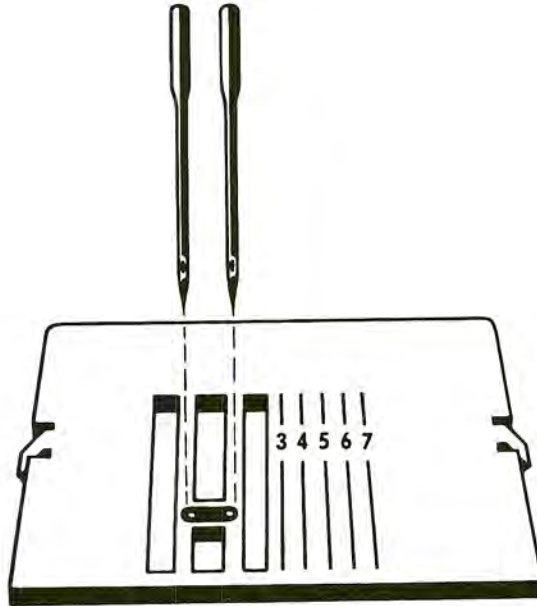

Note:

In order to make it possible to use a sword-bladed (Wing) needle for hemstitching, the stitch width is a little smaller than that used for other functional stitches. It is approx. 3 mm (1/8").

Check:

Turn the master selector dial to straight stitching and the needle position knob to its left position. Press the blind-stitch button. Rotate the balance wheel in sewing direction and check to see if the needle clears both ends of the slot at the same distance.



**Adjustment:**

If the needle throw is positioned too far to the left in the needle plate slot, turn regulating screw 6 in (clockwise), if it is too far to the right, turn it out (counter-clockwise). (Fig. 45a).

Fig. 45a

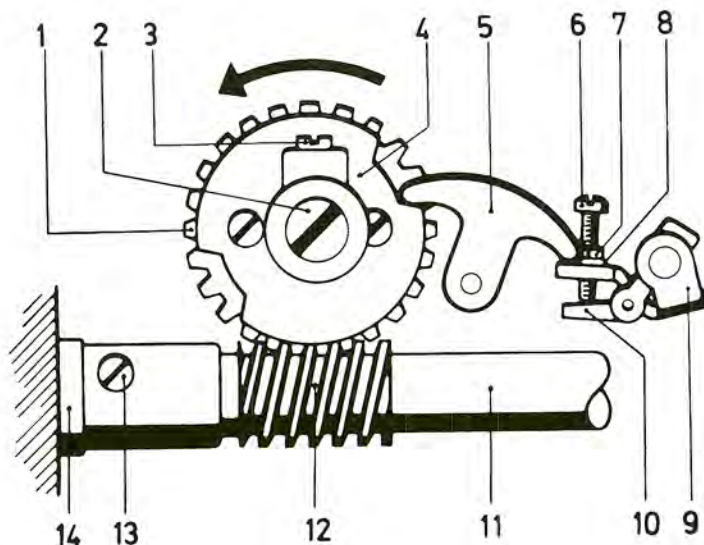

**Verification:**

Turn the balance wheel and check whether the needle throw is centered correctly in the needle plate slot so that the needle clears both ends at the same distance.

**46. Adjusting the Length of Forward and Backward Stitches for Hemstitching**

---

**Rule:**

When set for hemstitching, the machine should make forward and backward stitches of the same length.

**Note:**

This adjustment is only preliminary. Final adjustment must be made when the machine is sewn off.

Check:

Turn the master selector dial to stitch range 4 and the needle position knob to its left position. Press the hem-stitch button. Place a single lay of fabric under the sewing foot and a piece of thin cardboard on top of it. Turn the balance wheel in sewing direction and check to see if the needle in sewing backwards enters the hole made during forward sewing.

Fig. 46

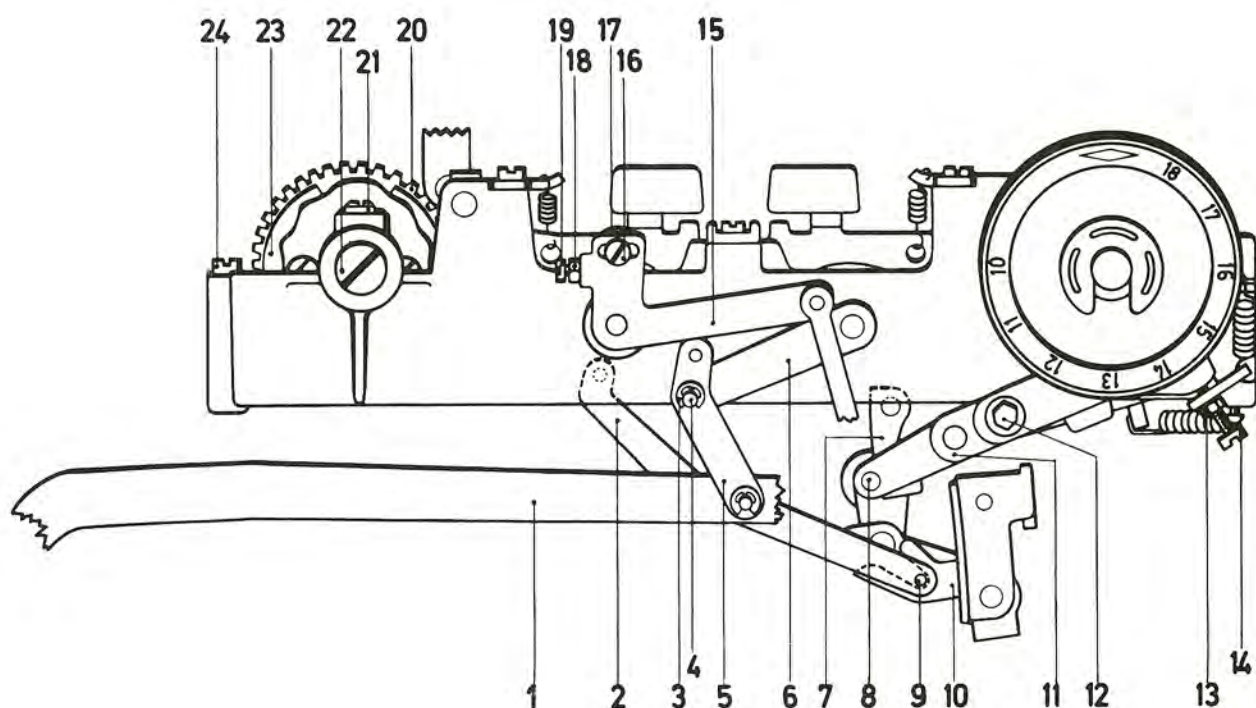

Adjustment:

If the needle does not enter the holes made previously, loosen screw 16 and nut 18 (Fig. 46). Turn regulating screw 19 out a few turns. Push regulating screw 19 lightly to the right and screw 16 to the left. Then lightly tighten screw 16 and turn in screw 19 very slowly until the needle enters the holes exactly. Check this by turning the balance wheel. Fully tighten screw 16 and nut 18.

Verification:

Let the machine run. The needle should now pierce the cardboard in exactly the same point when the machine sews forward and backward.

Variable-Ratio Automatic Mechanism

47. Setting the Feeler Fingers Close to the Cam Stack

Rule:

When engaged, the feeler fingers must contact cam stack 4 on the one side and lever 3 of pivot sleeve 6 on the other without any play (Fig. 47).

Check:

Turn the master selector dial to straight stitching and press the first push button marked with a diamond symbol. Turn the indicator wheel which serves to exactly locate the beginning of a pattern until the feeler finger is at the deepest point on the rim of the cam (Fig. 47). The symbol indicating the beginning of the pattern is then at the top. Push feeler finger 5 back and forth with a screwdriver to check it for play.

Fig. 47

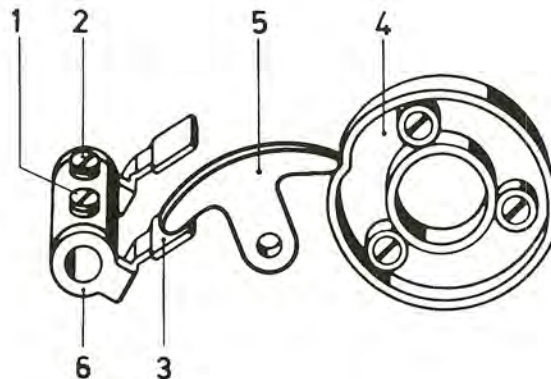

Adjustment:

If there is any play, slightly loosen screws 1 and 2. Lightly press screw 2 in needle bar direction until feeler finger 5 contacts cam 4. Hold it in this position and fully tighten screw 1.

Note:

If you press too hard against screw 2, the scalloping stitch will become too wide and the zero setting of the zigzag mechanism will be disturbed. If there is too much play between feeler finger and cam, the scalloping stitches will become too narrow.

Verification:

Check the feeler finger for play with the aid of a screwdriver. Pivot sleeve 6 should have no end play either. Tighten screw 2 very securely.



#### 48. Zeroing the Pattern Length Wheel

**Rule:**

When the pattern length wheel is turned to its stop and the diamond symbol is at the top, the wheel which serves to locate the beginning of the pattern must not turn. When you turn the pattern length wheel slightly toward 18, the pattern commencement locating wheel should begin to revolve slowly.

**Check:**

Turn the wheel lightly against its stop with the diamond symbol facing upwards. Let the machine run and check the setting.

Fig. 48

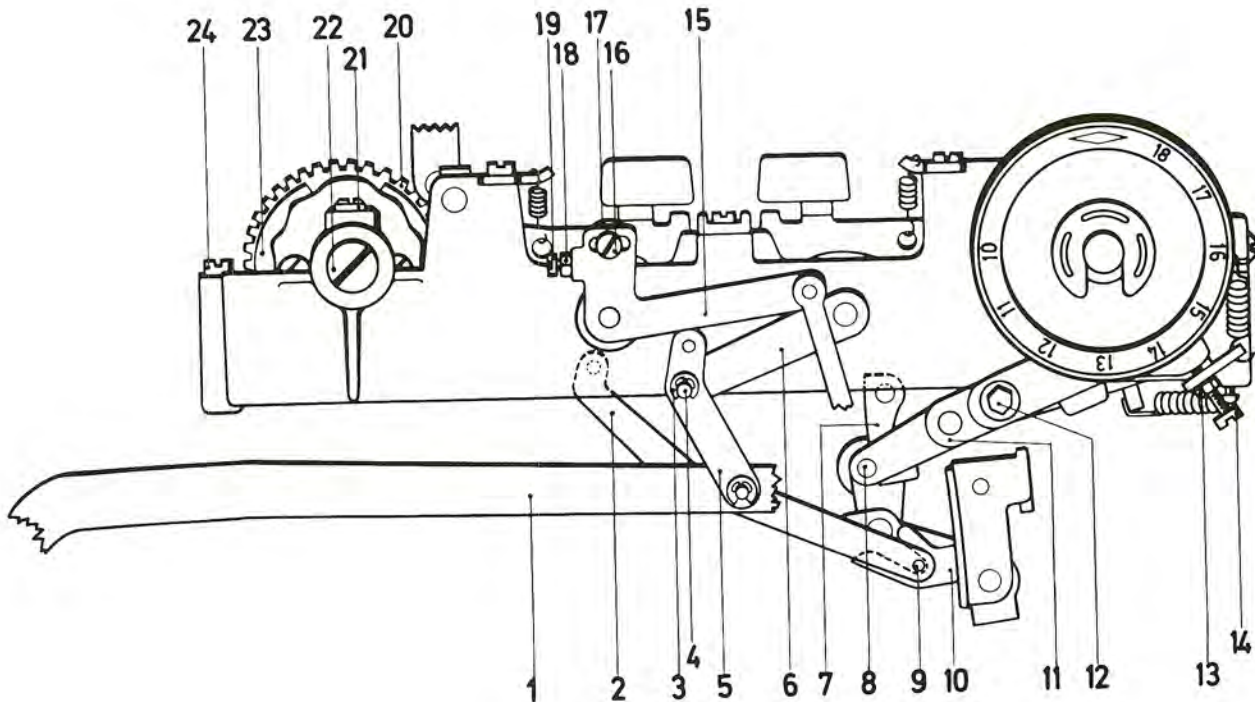

**Adjustment:**

Loosen hexagon screw 12 with a 5.5-mm spanner (Fig. 48). Turn screw 14 in two turns. Let the machine run and turn screw 14 very slowly out again until the pattern commencement locating wheel stops revolving. Lock nut 13 must retain its position in the process. It must be held in position by its lock washer. Fully tighten screw 12.

**Verification:**

Let the machine run slowly. Turn the pattern length wheel lightly against its stop with the diamond symbol facing upwards. The pattern commencement locating wheel must not move now. Turn the pattern length wheel a little away from its stop. The pattern commencement locating wheel must now begin to turn very slowly.

#### 49. Close Setting of Feeler Finger for Scallops

**Rule:**

When the feeler finger for scalloping is engaged, it must be in contact with the cam stack of the variable-motion automatic mechanism on the one side and the pivot sleeve of the fixed-ratio automatic mechanism on the other, without having any play.

**Check:**

Set the master selector dial to straight stitching and the needle position knob to its left position. Press the button for scalloping. Turn the pattern commencement locating wheel until the feeler finger is positioned at the deepest point of the cam (Fig. 49). The pattern commencement symbol then points upwards. Check lever ends 2 and 3 for play by pushing them back and forth with your finger.

Fig. 49

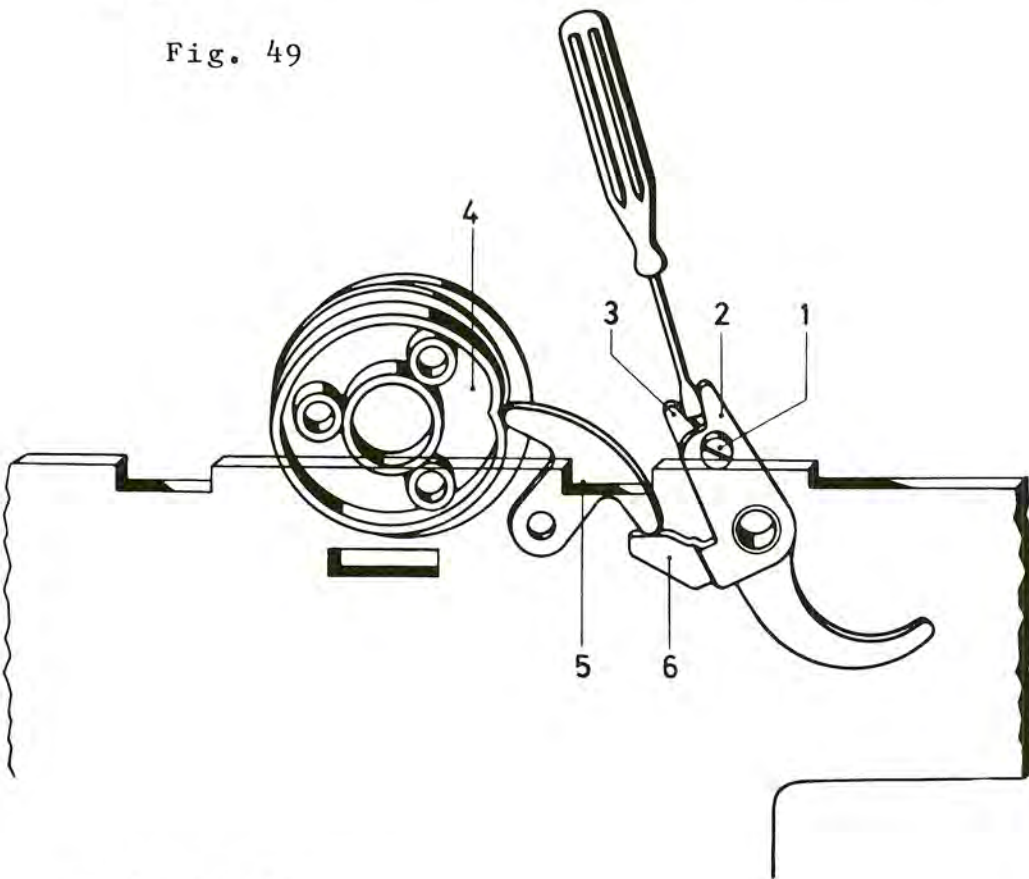

**Adjustment:**

If there is any play, loosen screw 1. Push the two lever ends 2 and 3 apart with a screwdriver until the play is eliminated. Hold the levers in this position and fully tighten screw 1 again.

**Verification:**

With your finger check the play of the feeler finger at lever ends 2 and 3. Turn the pattern length wheel to 10 and rotate the balance wheel. When the needle descends on the right and left of its widest throw, it should clear both ends of the needle plate slot at the same distance. If this is not the case, repeat the above adjustment until the distance are correct.

ELECTRICAL SYSTEM

50. Description of Electrical Equipment

The electrical equipment of the machine consists of:

- (1) motor,
- (2) control unit with master switch, all connections, maximum-speed regulation for machine and Stopmatic, and plug for mains connection,
- (3) foot control with potentiometer,
- (4) micro switch for Stopmatic,
- (5) sewing light.

Important note:

When making electrical repairs, be sure to comply with the safety regulations in effect in your country. Since part of the electrical system of these machines must only be tested at low tension, proceed in strict compliance with the testing instructions given. For this reason, all electrical repairs must be carried out by an expert. Furthermore, the repairer should stand on a rubber insulating mat and the machine should likewise be placed on such a mat.



51. Setting the Maximum Speed and the Speed of the Stopmatic Mechanism of Machines Operating on 220-240 V or 110-120 V

Rule:

After the machine has been running for five minutes at 20 °C and 220 V, its maximum speed should be abt. 920 r.p.m. and, with the Stopmatic control engaged, 120-160 r.p.m.

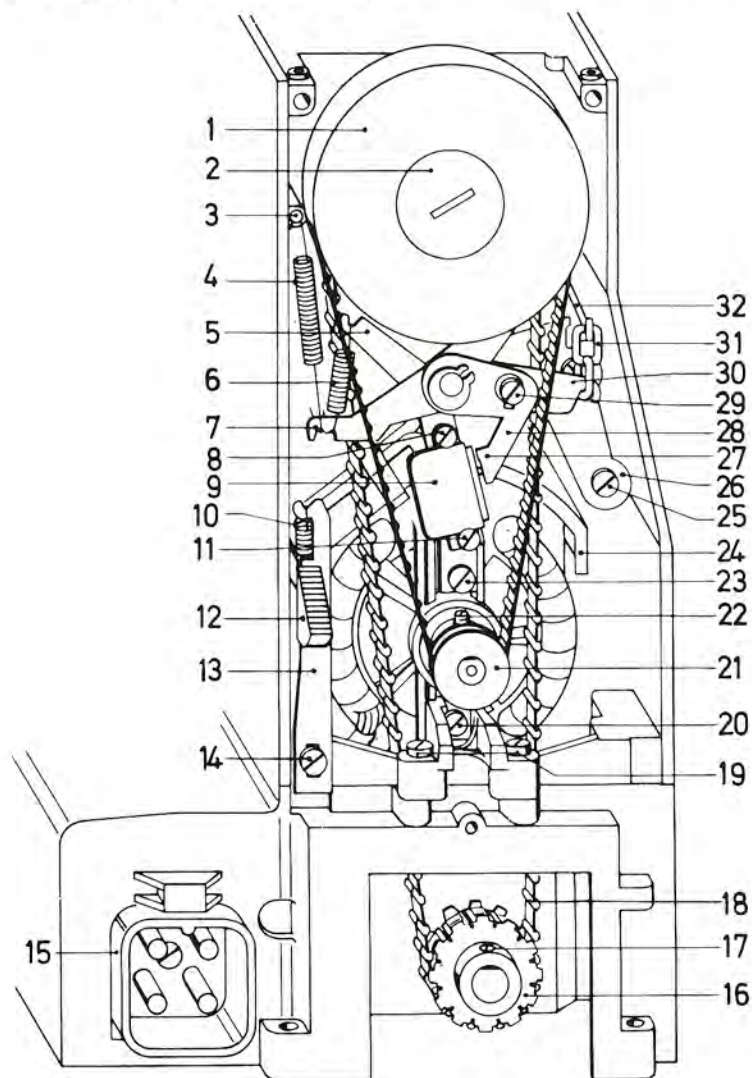

Fig. 51

Check:

Press the cancelling button of the automatic mechanism, raise the sewing foot, and let the machine run for five minutes. Unscrew the balance wheel, press the foot control pedal down as far as it will go. Check the maximum speed at the arm shaft with the machine standing upright. Release the foot control pedal and operate micro switch 9 (Fig. 51) by pushing it lightly to the left. The machine will now run at the low speed controlled by the Stopmatic mechanism, which is measured next. Minor deviations in speed are both possible and permissible.

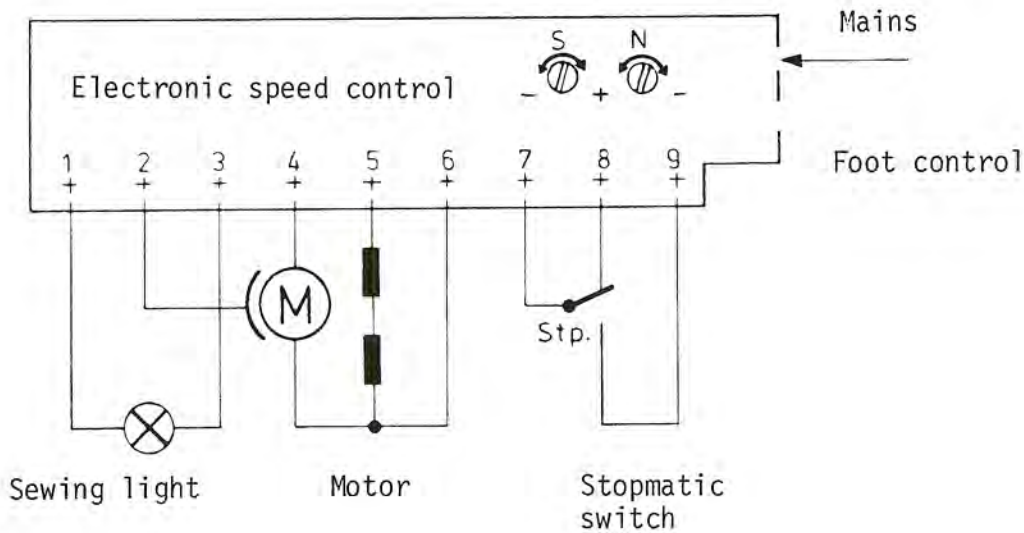

Fig. 51 a

#### Adjustment:

For safety reasons, pull the plug of the foot control cord out of the receptacle. Unscrew and remove the control housing cover. Regulator "N" serves for regulating the maximum speed of the machine, and regulator "S" for regulating the speed controlled by the Stopmatic mechanism (Fig. 51a). Adjustment of these regulators must be made very carefully without applying force, using a screwdriver which is fully insulated up to its blade and has a very thin handle to avoid turning the regulators too far. In most cases, it will be sufficient to turn the regulators by 10 to 20 degrees. First set regulator "N" controlling the maximum speed of the machine at abt. 920 r.p.m., then set regulator "S" at 120-160 r.p.m. Every adjustment of regulator "N" will automatically affect the speed set by regulator "S".

#### Verification:

Replace and screw on the housing cover and push the plug of the foot control cord into the receptacle in the control unit housing. Check both speeds with the machine standing upright.

51a. Setting the Maximum Speed of Machine and Stopmatic Mechanism on Machines Equipped with Dual-Voltage Motors (110 and 220 V)

Rule:

After the machine has been running for five minutes at 20 °C, the following speeds should be attained:

110 V

|                       |                  |
|-----------------------|------------------|
| Maximum machine speed | 850 - 920 r.p.m. |
| Stopmatic speed       | 150 - 160 r.p.m. |

220 V

|                               |                            |
|-------------------------------|----------------------------|
| Maximum machine speed         | 850 - 920 r.p.m.           |
| Stopmatic speed (old version) | 90 r.p.m. or slightly more |
| Stopmatic speed (new version) | 120 - 160 r.p.m.           |

Requirement:

The mains should supply a constant current of 110 and 220 V. In addition, a transformer is required which can be connected to 110/220-volt A.C. and has a capacity of 300 VA. (At 110 and 220 V, the power input of the machines is approx. 1 A).

Check:

See "Check" described in Section 51 of this Service Manual. In addition, check the speeds at both voltages (110 and 220 V).

Adjustment:

For safety reasons, pull the plug of the foot control cord out of the receptacle. Unscrew and remove the control housing cover. Regulator "N" serves for regulating the maximum speed at 110 V and regulator "S" at 220 V (Fig. 51b).

Adjustment of these regulators must be made very carefully without applying force, using a screwdriver which is fully insulated up to its blade and has a very thin handle to avoid turning the regulators too far. In most cases, it will be sufficient to turn the regulators by 10 to 20 degrees.

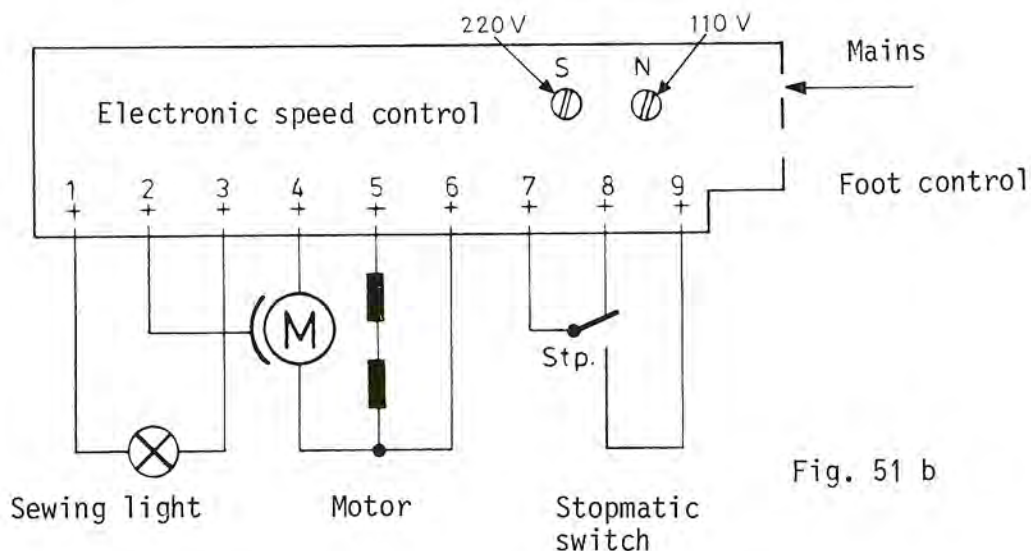

Fig. 51 b



To re-adjust all speeds, turn regulator "S" until its slot is positioned vertically. With the transformer switched to 110 V set regulator "N" at a maximum speed of 850 - 920 r.p.m. Then switch the transformer to 220 V and set regulator "S" at a maximum speed of 850 - 920 r.p.m., too. Check the speed at both voltages (110 and 220 V), and re-adjust, if necessary. Always set regulator "N" (110 V) first, then regulator "S" (220 V).

Now operate micro switch 9 (Fig. 52 c) by pushing it slightly to the left. Then with the transformer switched to 110 V, set regulator 9a at a speed of 150 - 160 r.p.m. Check the Stopmatic speed at 220 V. It must neither be below 90 r.p.m., nor above 160 r.p.m. If it is below 90 r.p.m., re-adjust the machine speed and, if necessary, increase it within the permissible range.

Verification:

Check the maximum speeds of the machine and the Stopmatic at 110 and 220 V.

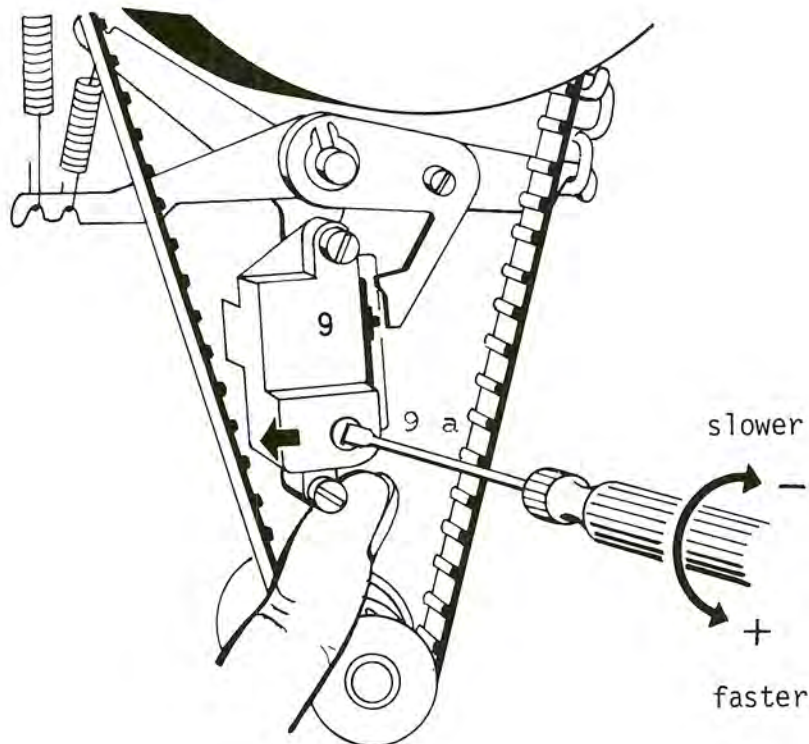

Fig. 52 c

51b. Different Versions of Machines Equipped with Electronic Control

| Voltage     | Type of motor | Motor No.    | Electronic control No.      | Printed circuit board from | Base plate colour | Colour marking on screw | Potentiometer in foot control |
|-------------|---------------|--------------|-----------------------------|----------------------------|-------------------|-------------------------|-------------------------------|
| 220 V       | GE 270        | 902-1013-001 | 93-050 080-91               | SEL                        | black             | Screw red               | 150 K                         |
| 110 V       | GE 270        | 902-1013-006 | 93-050 287-91               | SEL                        | black             | " black                 | 150 K                         |
| 220 V - SEV | GE 270        | 902-1013-001 | (obsolete)<br>93-050 357-91 | SEL                        | black             | " blue                  | 150 K                         |
| 240 V       | GE 270        | 902-1013-004 | 92-320 091-91               | PFAFF                      | light grey white  | " grey                  | 20 K                          |
| 110/220 V   | GE 271        | 902-1013-002 | 93-050 362-91               | PFAFF                      | light grey white  | " green                 | 20 K                          |
| 220 V       | GE 270        | 902-1013-001 | 93-050 446-91               | PFAFF                      | light grey white  | " red                   | 20 K                          |
| 110 V       | GE 270        | 902-1013-006 | 93-050 450-91               | PFAFF                      | light grey white  | " black                 | 20 K                          |
| 110/240 V   | GE 271        | 902-1013-002 | 93-050 688-91               | PFAFF                      | light grey white  | Socket green head       | 20 K                          |

Note: The versions for 110/220 V and 110/240 V have an additional micro switch with regulator.

If the Pfaff 1221 is to be used as a portable machine, remove the adapter so that you can see the colour of the socket base plate (black, white or grey). The adapter can be used for both controls.

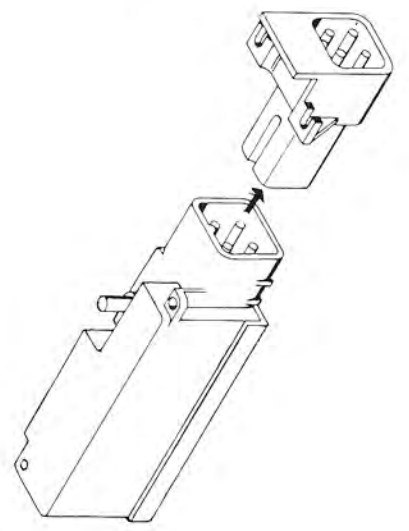
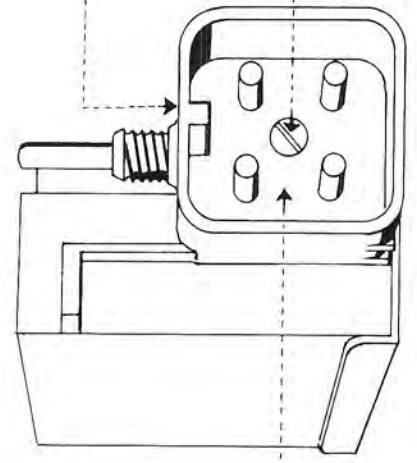

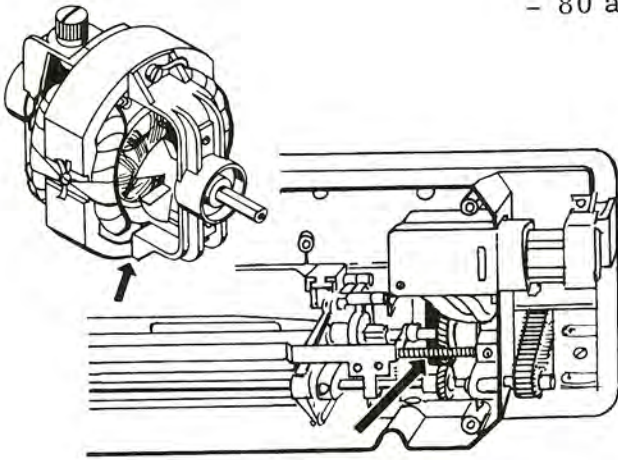

Motor

The number and the voltage are visible after removing the base plate.

Foot control

Outside markings:

SEL:

- 1. AT 0001 to AT 0009
- 2. No P on base plate

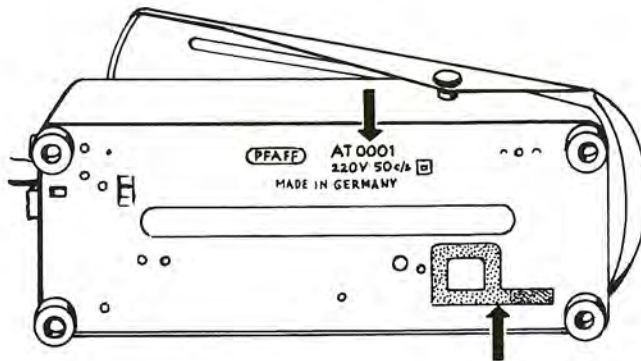

PFAFF:

- 1. AT 0012  
AT 0013  
AT 0014  
AT 0015  
AT 0017  
AT 0018
- 2. P on base plate

Differences in internal setup:

SEL:

- Potentiometer  
150 K  
No. 93-050 215-95
- 1 resistor  
33 K $\Omega$   
No. 93-050 344-91

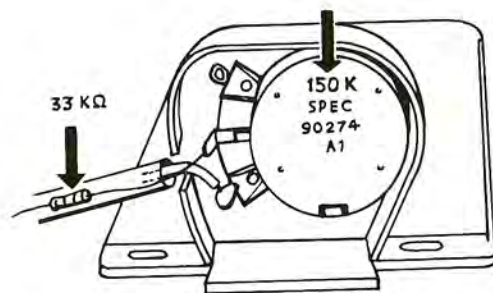

PFAFF:

- Potentiometer  
20 K $\Omega$   
No. 93-050 321-95
- no resistor

Note: All plastic foot controls are equipped with the Pfaff potentiometer with 20 K $\Omega$ .



51c. Exchanging the Potentiometer in the Foot Control of Models 1221 and 1222

Pull the power cord plug out of the mains socket. Take out the screw next to the cord inlet and remove the foot control cap. Unscrew and remove the mounting bracket with potentiometer and disconnect the potentiometer wire from the terminal block.

To fit a new potentiometer, proceed as instructed under a to e.

Re-use the insulating tube of the old potentiometer.

a Turn the potentiometer shaft clockwise as far as it will go.



b Replace the mounting bracket and turn in the screw until it is finger-tight.

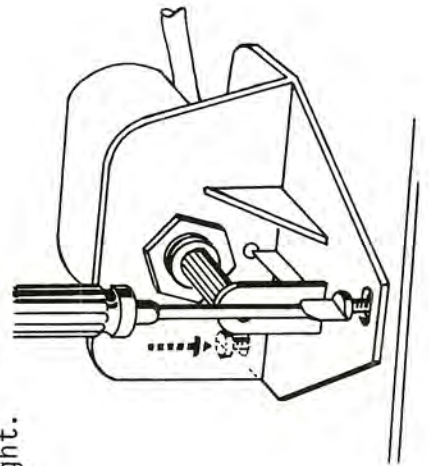

c Push the mounting bracket toward the left until the teeth of the potentiometer shaft and those of the toothed segment are in mesh. Push the toothed segment bar half-way down and hold it in this position. Tighten the screws of the mounting bracket securely.

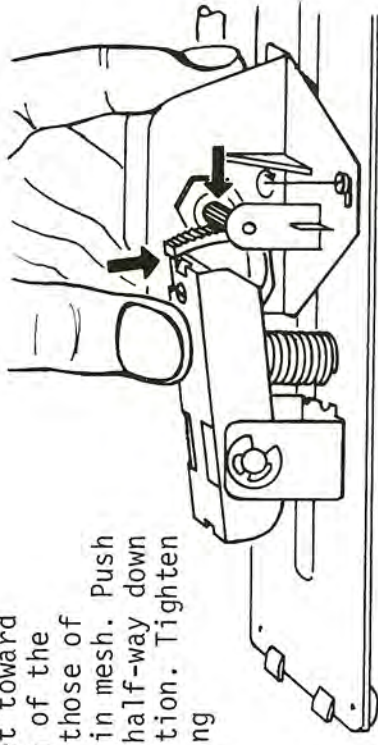

d Release the mounting bracket and connect the potentiometer wire to the terminal block.

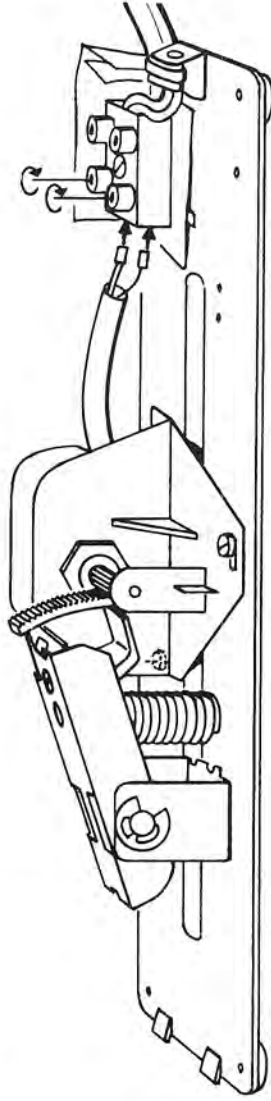

e After replacing the cap, check the resistance with the aid of an ohmmeter. Insert the measuring pins of the ohmmeter into the pin holes near the left-hand side (without guide groove) of the attachment plug. On both the Pfaff and SEL versions the resistance must be  $\infty$  when the foot control is in its inoperative position. When the foot control pedal is pressed down as far as it will go the resistance on the Pfaff version should be 0 and on the SEL version abt. 35  $K\Omega$

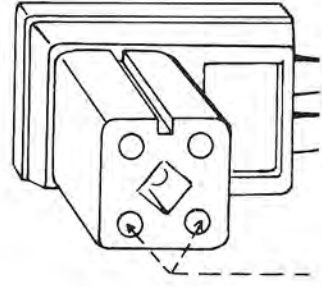

Connect ohmmeter here

How to trace defects in the electrical and electronic systems of 1200 series machines

- 1 Light fails to go on, machine is running.

Change light bulb.

Trouble eliminated, light bulb was defective.

Trouble still exists.

Contact pins jam in lamp socket.

Trouble eliminated, lamp socket was defective.

- 2 Light fails to go on after changing light bulb, machine does not run.

Change fuse on Pfaff control unit.

Trouble eliminated, fuse was defective.

Trouble still exists.

- 3 Light is on, machine does not run.

Trouble eliminated, foot control was defective.

Trouble eliminated, micro switch was defective.

Trouble eliminated, motor was defective.

Trouble eliminated, control unit was defective.

- 4 Light is on, machine is running although foot control is not operated.

- 5 Light is on, machine is running irregularly.

Replace foot control by new one.

Trouble still exists.

Push replacement micro switch onto contacts 7, 8 and 9.

Trouble still exists.

Push replacement motor onto contacts 2, 4, 5 and 6.

Trouble still exists.

Replace control unit.

6 Light is on. Rated speed not correct, even after adjusting control unit.

7 Light is on, machine speed decreases, smell of burning.

Check to make sure correct foot control is used.

Trouble eliminated, foot control was not correct.

After changing the motor, keep check on the machine for 10 to 15 minutes (if necessary, replace control unit).

8 Machine interferes with radio and TV reception.

Use motor equipped with radio noise filter.

9 Stopmatic mechanism running too fast, cannot be adjusted.



# Testing instructions (trouble shooting chart) for the electrical and electronical systems incorporated in 1200 series machines

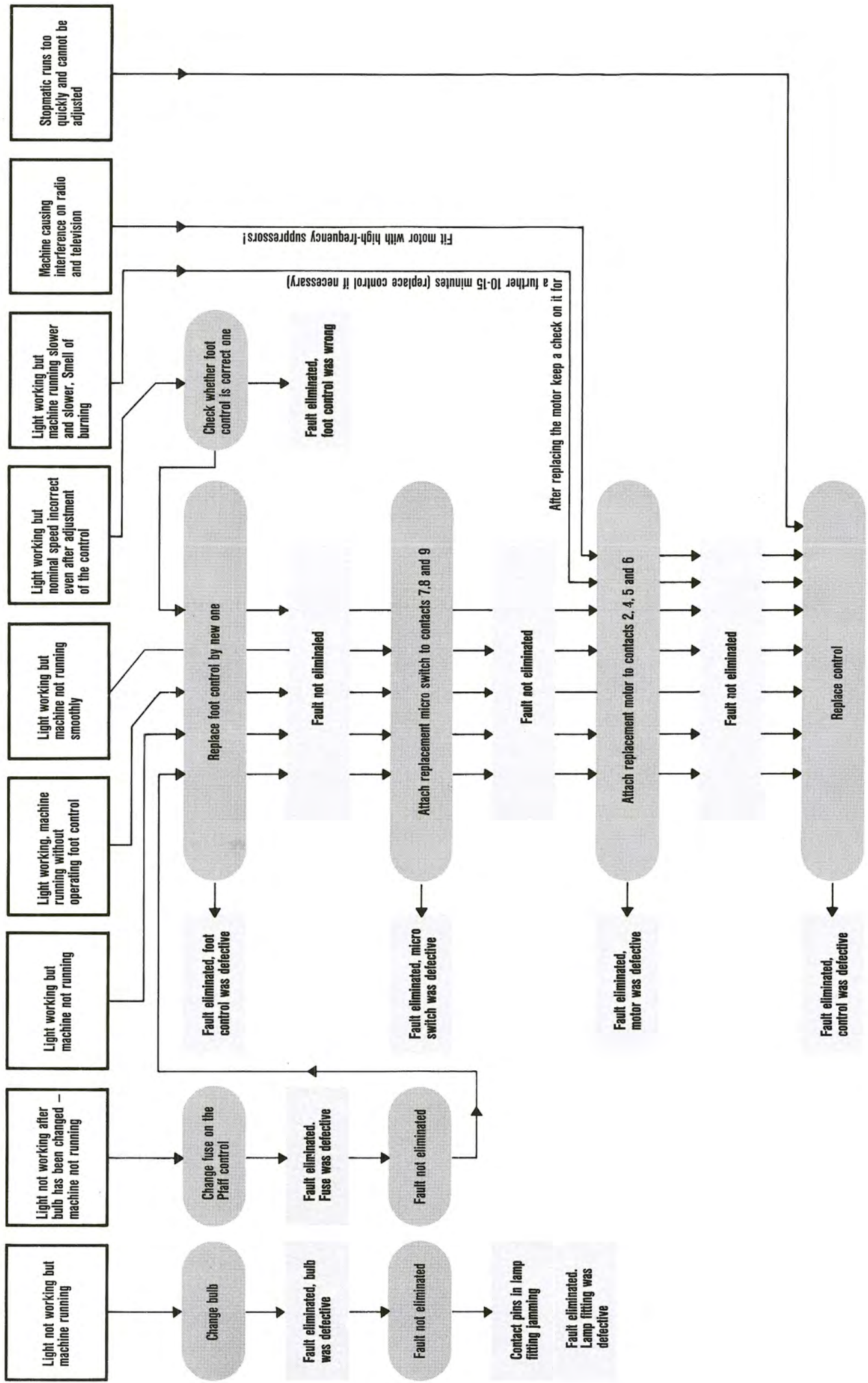

54. Test Procedure and Trouble Shooting in the Electrical System

If a machine which is properly connected to the mains (note type of current and voltage) does not start running when the foot control pedal is depressed slowly, apply the following test procedure:

1. Checking the Current Supply

The current supply works properly if the sewing light lights up when the red master switch is pressed. Prerequisite for this is that the bulb is in order. If the bulb is not in order. If the bulb is not in order, the machine drive and the speed control would nevertheless work properly. If the sewing light does not light up, exchange the foot control together with its cord.

2. Checking the Foot Control

If the sewing lamp lights up, but the machine cannot be started by pressing down the foot control pedal, exchange the foot control together with its cord.

3. Checking the Stopmatic Switch

Operate the Stopmatic switch by pressing it to one side by hand and check if the machine runs at the reduced speed controlled by the Stopmatic mechanism. If it does, this proves that the Stopmatic switch and the electronic unit are in order. As the switch is operated, it makes a switching noise. This check double-checks the above check of the foot control. If this action, too, fails to start the machine, the fault is likely to be in the electronic unit.

4. Checking the Electronic Unit

Remove the base plate on free-arm machines or the bottom plate on flatbed machines, pull the plug out of the wall socket and remove the cover of the control unit housing. Check if the wires marked by numbers 1 through 9 are connected to the appropriate tongues. If no error is found here, pull out all flat plugs.

The connections of the sewing lamp are identified by numbers 1 and 3, those of the motor by numbers 2, 4, 5 and 6, and those of the Stopmatic switch by numbers 7, 8 and 9. After pulling the connections off the respective terminals, these electrical parts can now be checked singly for proper working. This check is naturally limited to the part which can be checked by means of the disconnected wire. Electronic parts must no longer be checked with the aid of conventional testing equipment (testing lamp for 220 V or other voltages or watt meters). Meters having a capacity of up to 500 kOhm are best suited for these tests. If the fault lies in the electronic system, the complete control unit must be exchanged and returned to us.

SEWING OFF

55. Adjusting the Bobbin Winder

**Rule:**

The bobbin winder should distribute the thread evenly and should stop when the thread wound on the bobbin has reached a point about 1 mm (1/32") below its rim. If the thread piles up at one end, set the thread retainer stud higher or lower. If the bobbin winder stops too early or too late, adjust the stop spring.

**Adjustment of the Stop Spring:**

Loosen both screws 1 (Fig. 55). For more thread, move stop spring 2 towards its retaining screws, for less thread, move it in the opposite direction.

Fig. 55

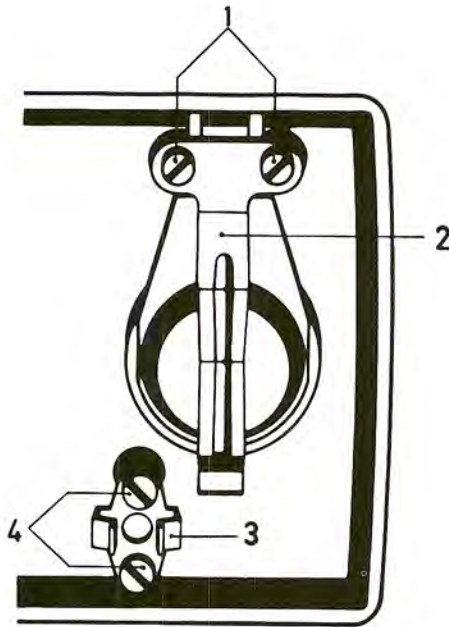

**Verification:**

To check the above setting, wind a bobbin.



### Adjustment of the Thread Retainer Stud:

If the thread piles up at the top end of the bobbin, tap the thread retainer stud deeper into the top cover. If, on the other hand, the thread piles up at the lower end of the bobbin, strip the tension spring and tap against the lower end of the thread retainer stud to set it higher.

### Verification:

To check if the bobbin winder works properly, wind a bobbin.

### 56. Operation of Needle Threader

The needle threading position is identical with the position in which the needle bar is retained by the Stopmatic mechanism. When the needle threader control is pressed down, the needle threader bar moves downwards and is automatically turned by a pin riding in the oblique slot in the needle threader bar housing. As the threader bar is turned, the threader prong enters the needle eye from the back. It draws the thread through the needle eye when the threader control is released again and casts it off.

### 57. Adjusting the Threader Bar Collar

#### Rule:

When the threader control is depressed, pin 2 (Fig. 57) should move in the oblique slot 3 in the threader bar housing from its lower end all the way to its upper end and bear against the latter. There should now be a clearance of 0.5 mm (.02") between the bottom end of threader bar housing 5 and lower bearing 6 of needle threader bar 7.

#### Check:

Remove the face cover and rotate the balance wheel until the needle bar is retained in its upper position by the Stopmatic mechanism. Fully depress the needle threader control and hold it in its lower position.

#### Adjustment:

Loosen screw 1 with the aid of a 5.5-mm spanner and set the collar on the threader bar higher or lower, as may be required, making sure however it is always set at right angles. Fully tighten screw 1 again.

Fig. 57

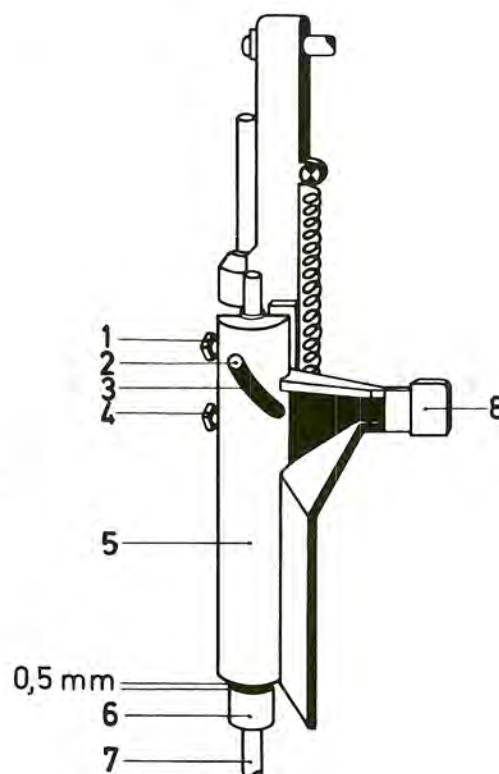

Verification:

Fully depress the needle threader control and check the clearance. Rotate the balance wheel and check to make sure that the collar on the needle threader bar does not foul the threader bar housing when the needle bar is at its highest point.

53. Adjusting the Needle Threader Head

Rule:

When the needle threader control is depressed completely, prong 6 should enter the needle eye sufficiently to allow the needle thread to be placed under it easily. When using a No. 70 needle, the threader prong should pass through the needle eye approximately midway between its top and bottom ends. There should be the same clearance between the prong and the right and left sides of the needle eye, respectively (Fig. 53).

Check:

Insert a new needle (System 130, No. 70) and operate the Stopmatic control. With the face cover replaced, depress the needle threader control and check to see if it works properly.

Fig. 53

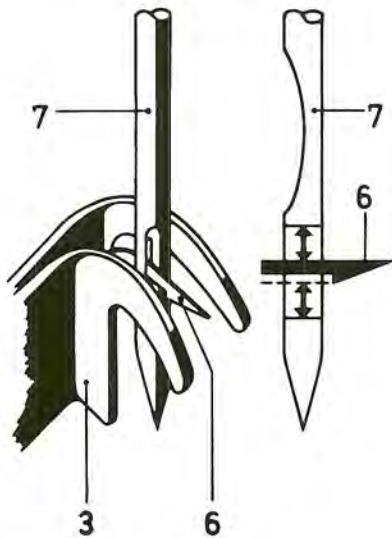
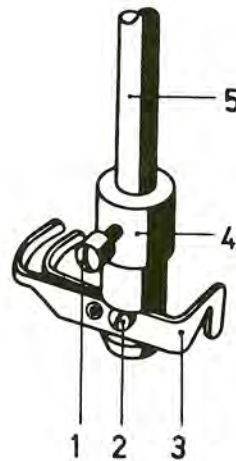

Fig. 58a



Adjustment:

Loosen screw 1 (Fig. 58a). Depress the needle threader control and hold it in this position. Place threader head so on threader bar 5 that prong 6 passes freely through the needle eye and protrudes sufficiently at the front. Adjust threader head 4 vertically until prong 6 is positioned in the middle of the needle eye vertically. With the threader head in this position, lightly tighten screw 1 again. Now loosen screw 2 on the threader head and adjust hook 3 laterally until prong 6 is centered in the needle eye horizontally. Securely tighten screw 2.



Verification:

Operate the Stopmatic control and thread the needle with the aid of the automatic needle threader. Then tighten screws 1 and 2 securely.

59. Tension Regulation

Both threads should be locked in the center of the material, as shown in Fig. 59. To achieve this, the needle thread is tensioned by an adjustable disc tension and the bobbin thread by an adjustable leaf-spring tension on the bobbin case.

Fig. 59



60. Adjusting the Bobbin Thread Tension

Rule:

A weight of 20 to 25 grams should be required to draw the thread through the bobbin thread tension.

Check:

When you hold the bobbin case by the protruding thread end, it must not be pulled down by its own weight. When you jerk your hand up, the thread should be drawn from the bobbin gradually (Fig. 60).

Adjustment:

Make sure there are no loose thread ends under the tension spring. Check to see that the tension spring lies on the bobbin case evenly all the way from the delivery eye to its tip and that it parallels the edges of the bobbin case. Slightly turn out the knurled regulating screw, then turn it in again until a noticeable resistance is felt when you draw the thread through the tension.

Fig. 60

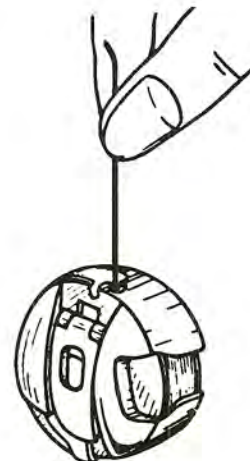

Verification:

See under "Check" above.

Note:

Once the bobbin thread tension has been set correctly, any tension regulation which may become necessary later should only be made adjusting the needle thread tension.



## 61. Adjusting the Needle Thread Tension

Rule:

Within the tension range of 3 - 5, if staple fibre 100/3 or cotton thread 50/3 is used, the threads should lock in the center of the material during straight and zig - zag stitching.

Check:

Set upper tension dial on 5 and sew medium length straight and zig - zag stitches.

Fig. 61

Adjustment:

Remove the face cover and loosen screw 12 (Fig. 61). Lightly tighten screw 12 again. Gradually lower regulating bracket 1 until both threads are locked in the center of the material. Lightly tighten screw 12 again.

Verification:

Check the interlocking of the threads with the machine set for its widest zigzag stitch and for a straight stitch of medium length. Tighten screw 12 securely.

Note:

When using different sewing threads it may be necessary to increase or decrease the needle thread tension by one or two grades (numbers). When synthetic threads continuous filament are used which are often more elastic than natural-fiber threads, the needle and bobbin thread tensions must be eased as much as possible. In this case, set the bobbin thread tension so that the bobbin case with the bobbin will slide down slowly when holding it by the thread end. The thread must not be stretched when it is wound on the bobbin. The needle thread tension should be set so light that the thread will pass through it smoothly without being stretched as you pull it toward the thread check spring by hand.

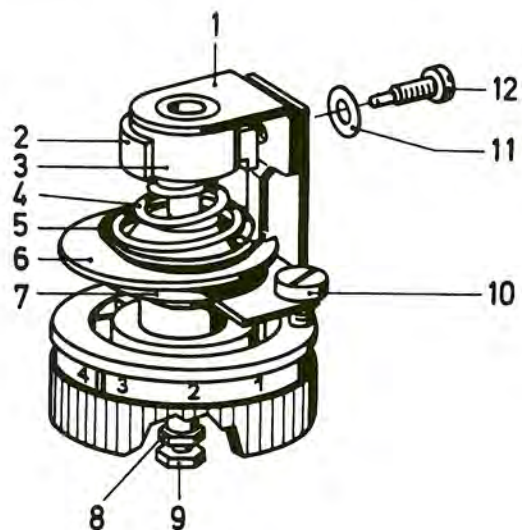

## 62. Adjusting the Tension Release Mechanism

Rule: ( only old version )

When the presser bar lifter is raised, the tension release washer should be lifted 0.3 to 0.5 mm (.01" to .02") and the tension be released.

Check:

Raise the presser bar lifter. Pull a thread through the needle thread tension. There should be no tension now.

Fig. 62

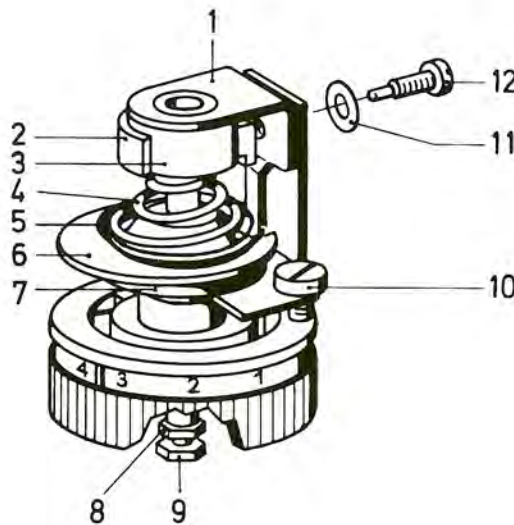

Adjustment:

Remove the face cover and raise the presser bar lifter. Loosen nut 8 (Fig. 62), using a 5-mm spanner, but hold regulating screw 9 so that it will not turn. Take the same spanner and turn the regulating screw until the tension release washer is lifted 0.3 to 0.5 mm. Tighten the nut, without turning the screw however.

Verification:

Lower the presser bar lifter, then raise it again. Repeat the check described under "Check" above.

63. Adjusting the Stroke of the Thread Check Spring

The thread check spring prevents that the slack thread caused by the descending take-up lever is pierced by the needle.

Rule:

Thread check spring 2 should hold needle thread 5 taut until needle point 3 enters fabric 4. At this point, the thread check spring should be through acting. The needle thread must be released by the thread check spring when the lower end of the needle eye is flush with the goods (Fig. 63).

Fig. 63

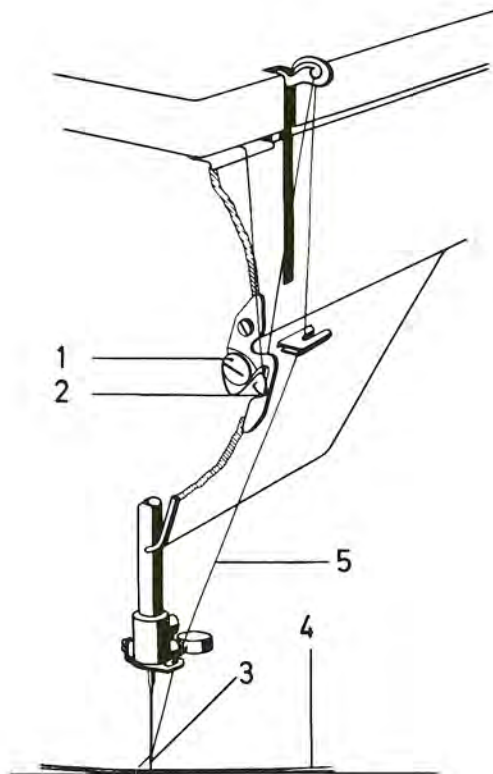

Check:

To check, set the machine for its longest stitch and sew a few straight stitches. Then turn the balance wheel to determine the end of the thread check spring stroke. The precise moment when the needle thread is released can be clearly determined by watching its tautness at the needle eye. The needle thread is released by the thread check spring when it enters the needle eye in a curve instead of a straight line.

Adjustment:

Remove the face cover and slightly turn in screw 1 to position the thread check spring correctly.



Verification:

Check with the machine set for its longest stitch if the thread check spring works properly, i.e. if its stroke is timed correctly.

64. Adjusting the Length of Forward and Backward Stitches for Hemstitching

Rule:

When the machine is set for hemstitching, the master selector dial is set at 4 and the needle position knob at its left position, the machine should sew forward and reverse stitches of the same length.

Check:

To check this, use a System 130 needle in size 80.

Adjustment:

If the needle in sewing backwards does not enter the holes made previously, loosen nut 18 and screw 16 (Fig. 64). Turn regulating screw 19 slightly in or out until the needle enters the holes exactly. Securely tighten screw 16 and nut 18.

Fig. 64

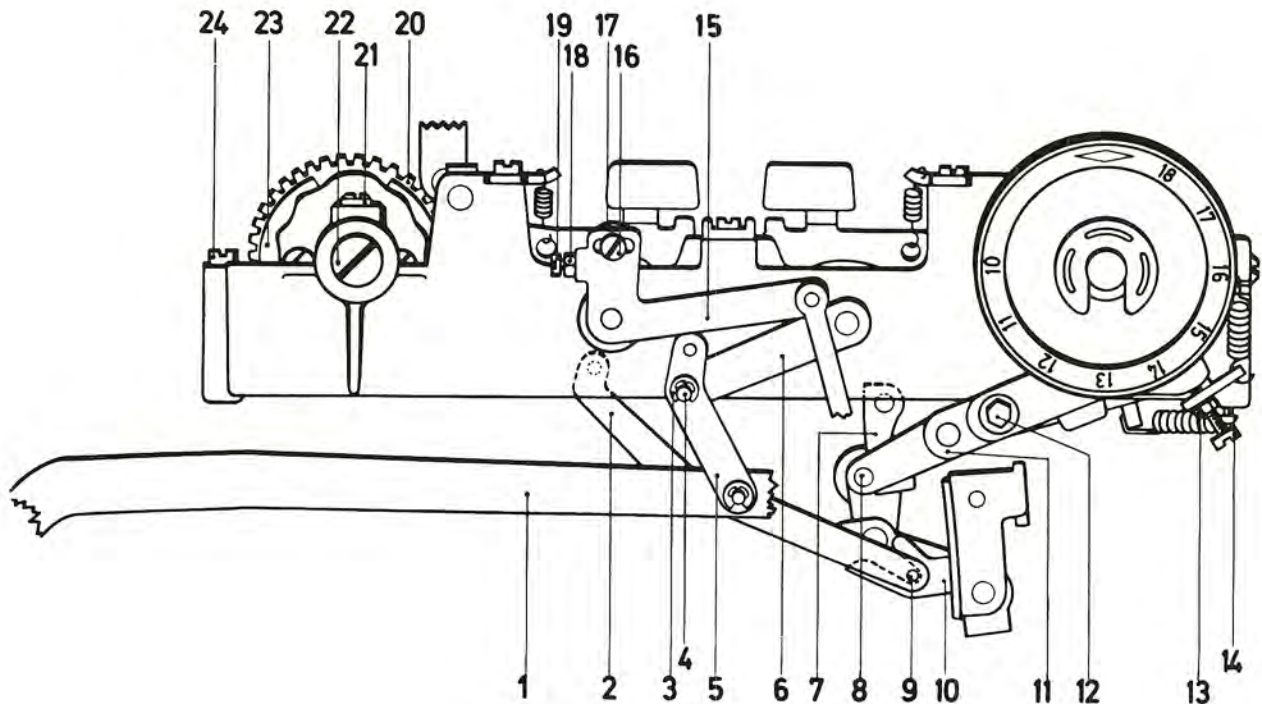

Verification:

For hemstitching, insert a sword-bladed System 130 needle in size 110. If necessary, repeat the above adjustment.

64a. Setting the Household Overlock Stitch

Note:

Effective May 1976 the machines will be provided with a household overlock stitch in place of the hemstitch previously incorporated.

Rule:

When the machine is set for the household overlock stitch the needle must always penetrate the same penetration holes both during forward and reverse feeding.

Check:

Press the push button with the symbol illustrating the overlock stitch. Then the master dial has to be set on "4" and the needle position knob for needle position "left". Now attach the standard zigzag presser foot and start to sew.

Adjustment:

Loosen nut (18) (Fig. 64) and screw (19) by approx. two turns. Then loosen screw (16) and slightly tighten same again. Start to sew the overlock stitch while simultaneously tighten screw (19) until the stitch is set so that the needle penetrates the same hole both during forward and during reverse feeding. Now tighten screw (16) securely and nut (18) just sufficiently so that it would not loosen.

Verification:

Sew the overlock stitch and check the needle penetration during forward and reverse feeding.

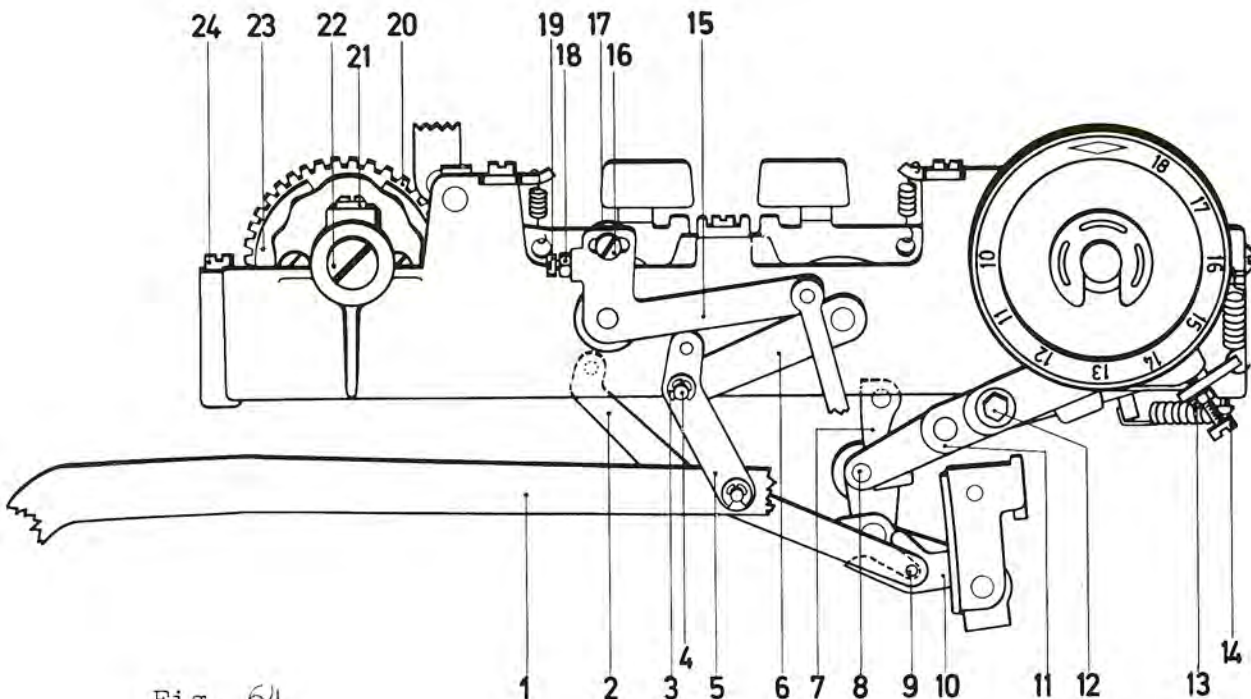

Fig. 64

65. Adjusting the Length of Forward and Backward Stitches  
for Triple-Stitch Seams

Rule:

When the triple-stitch button is pressed, the master selector dial is turned to 4 and the needle position knob to its central position, the machine should sew forward and reverse stitches of the same length.

Check:

To check this, use a System 130 needle in size 80.

Note:

Prerequisite for this adjustment is that the stitch length setting for hemstitching is correct.

Adjustment:

If the needle does not enter the holes made previously, slightly turn regulating screw 1 in the engaged feeler finger 5 in or out (Fig. 65) until the forward and the backward stitches are the same length.

Fig. 65

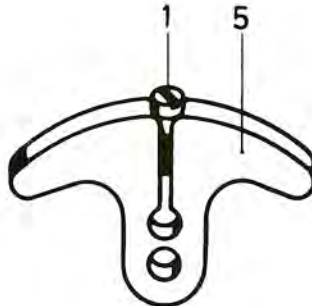

Verification:

Sew a triple-stitch and a hemstitching seam and, if necessary, repeat the above adjustment.



## 66. Making a Sample Swatch

After all adjustments and checks have been made and the machine sews satisfactorily, sew a sample swatch, showing the most important sewing operations that can be performed on this machine.

1. Straight stitching, varying stitch length and sewing direction.
2. Zigzag stitching in the four stitch widths and various stitch lengths.
3. All functional stitches, including hemstitching.
4. On Pfaff machines 1222 and 1221 all decorative stitches in all three needle positions and in two pattern lengths.
5. A buttonhole about 20 mm long.
6. On Pfaff machines 1222 and 1221 a narrow strip of a difficult-to-handle material about 50 cm (20") long should be used to sew a smooth seam without any disarrangement of fabric plies.

M. F.

PH/VHA- PIX/ÜBS  
February 1970

Various repair jobs

66. Changing the motor and the carbon brushes

(Under normal conditions, changing the motor will take 45 to 60 minutes.)

Removing the motor:

Remove the arm cover and loosen the two small screws in the machine housing above the balance wheel.

On flatbed machines take out a screw below the bedplate, on free-arm machines a screw which is located roughly in the middle of the arm standard cover. Remove the arm standard cover.

On free-arm machines take out the five screws of the bottom plate and remove the bottom plate. Remove the needle.

Unscrew the control box housing cover. On machines fitted with electronic control, remove cords No. 2, 4, 5 and 6, on machines without electronic control, cords No. 1 and 3.

In order to save a subsequent adjustment of the needle bar rise and timing of the feed motion, bring the machine to the needle bar rise position now, and mark the cord belt and the cord belt sprockets.

To this end, bring the needle bar to the bottom of its stroke. Then slip the C-clamp and the 2-mm-thick gauge onto the needle bar without any play. Pull out the gauge and turn the balance wheel until the clamp contacts the arm casting.

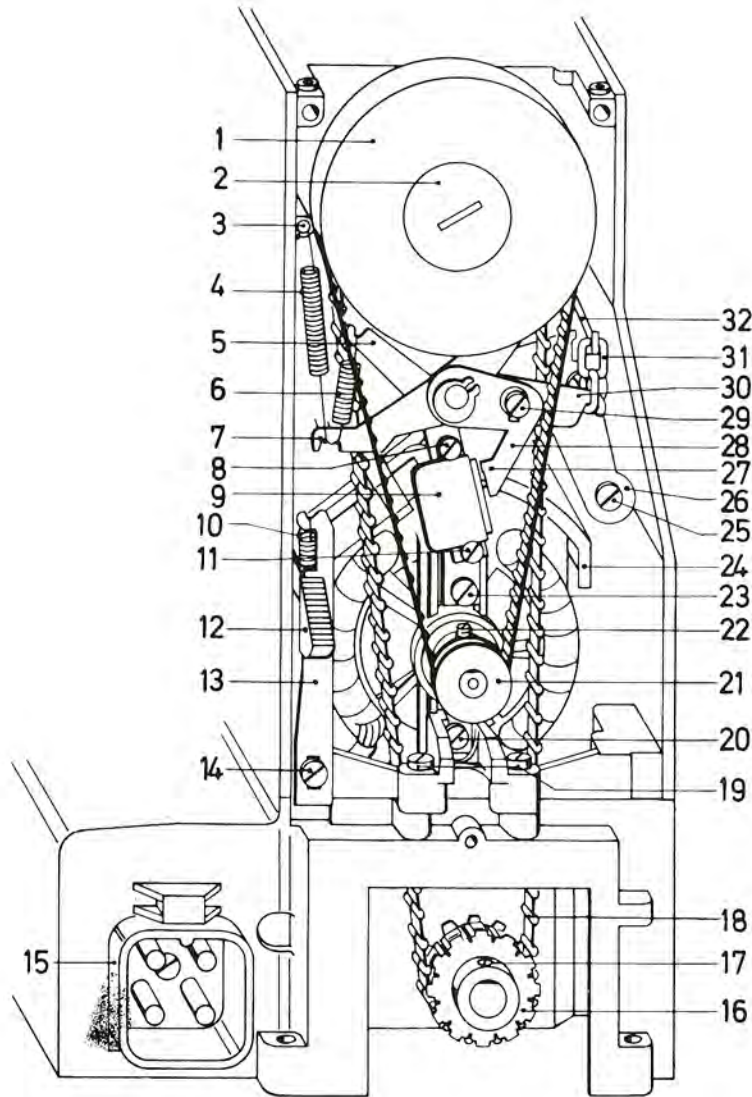

Fig. 66

Mark the upper sprocket with a cross and mark the belt on the same place with an arrow in sewing direction of the machine. Mark the lower sprocket and the belt with a line.

Unscrew the balance wheel and remove the cleated belt. Remove the complete roller clutch. Disconnect tension spring 4 (Fig. 66). Turn out both screws 25 and remove connecting link 31. Detach the cord retaining spring and take the cords out of the groove of the motor casing. Strip cord belt 18. Turn out screw 23 and pull out the motor casing. Then turn out both screws 19, and take the motor out of the machine.



## Changing the carbon brushes and cleaning the motor

(Under normal conditions this job will take 10 to 15 minutes)

If the carbon brushes are worn so much that they no longer contact the collector under spring pressure, they must be exchanged. In addition, the motor, and particularly the collector, must be cleaned and all carbon particles be removed. If any carbon particles remain on the motor or the collector, creeping currents may occur which cause a loss of power. This surface leakage current in the course of time may lead to a destruction of the collector, thus rendering the motor unserviceable. For this reason, the motor should be stripped and cleaned whenever the carbon brushes are exchanged.

After having removed the carbon brushes, clean the motor with a dry and clean soft brush or with a jet of compressed air. Never use any cleaning fluids. If necessary, the collector may be cleaned with polishing linen No. 00. If the collector has very deep grooves, it is best to send the complete motor to the factory for re-turning.

When inserting new carbon brushes, make sure that the connecting wire inside the pressure spring will not be wedged and that the U-shaped contact cap on the end of the spring is seated correctly in the carbon brush duct. The two caps should only be tightened by hand.

### Installing the motor:

Insert the motor cord into the channel and the motor into the machine. Pull cord belt 18 (Fig. 66a) up and position it to the right and left of motor bracket 19. Install the motor casing and tighten it with screw 23 and a toothed washer. Insert the light and Stopmatic cords into the groove of the motor casing and secure them in place with the cord retaining spring. Tighten the motor with the two screws 19. Mount cord so that the arrow and line marking of the cord belt are in line with the cross and line marking on the cord belt sprockets. The point of the hook must be on the center line of the needle and the feed-dog under the needle-plate. Remove the C-clamp.

Mount bracket 26 together with the clutch levers and the micro switch assembly, and tighten them with screws 25, making sure that the lug of bracket 26 enters the lower hole in bell crank 32. Mount connecting link 31 and tension spring 4.

Adjust the clutch lever as described under 1 of the Service Manual. Mount the roller clutch and adjust it as described under 2 of the Service Manual. Mount the cleated belt and attach the balance wheel. Mount motor cords No.2,4, 5 and 6 on machines fitted with electronic control, or cords No. 1 and 3 on machines without electronic control. On electronically controlled machines, adjust the maximum speed for the motor and the Stopmatic mechanism as described under 51 of the Service Manual. Mount the control box cover as well as all remaining covers, etc.

Note:

When repairing electrical appliances of every kind, check the respective appliance in order to make sure it conforms to the safety regulations in effect in your country.

All electrical repairs should be performed by an expert.



Abb. 66a

67. Changing the pressure spring in the balance-wheel release knob

(only on machines without Stopmatic mechanism)

(This job will take about 5 minutes)

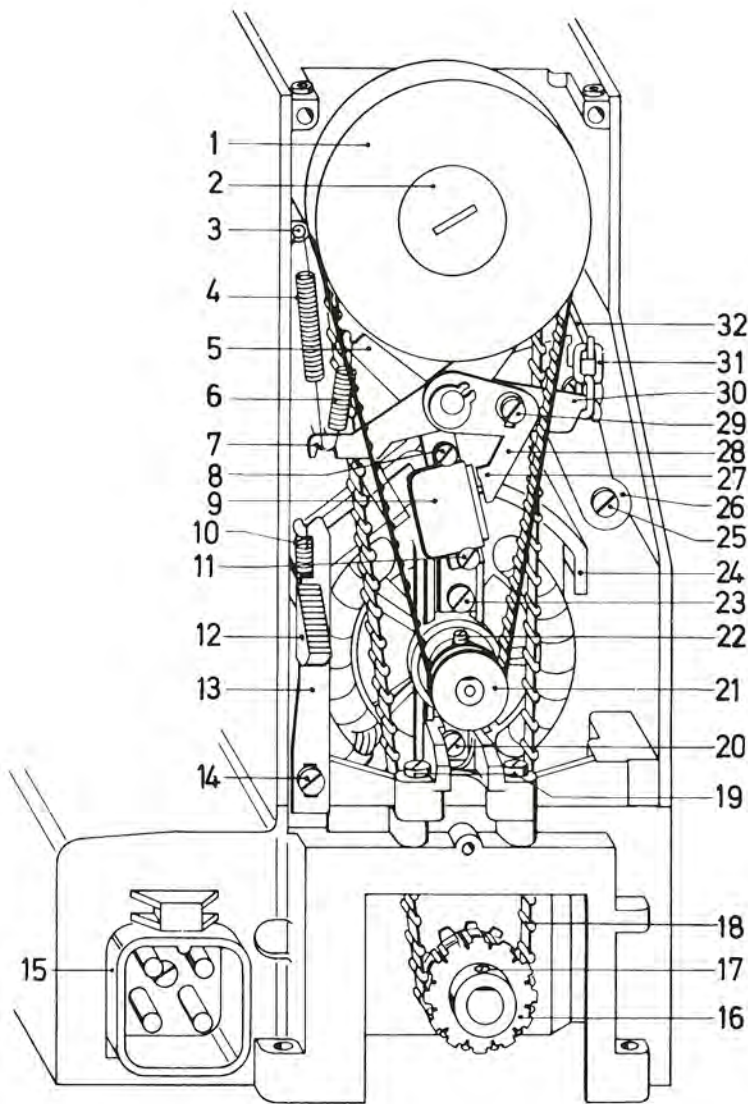
Removal:

Turn out screw 11 (Fig. 67) and remove washer 10. Pull out balance-wheel release knob 8, and take out locking lever 7, clutch collar 5 and pressure spring 4.

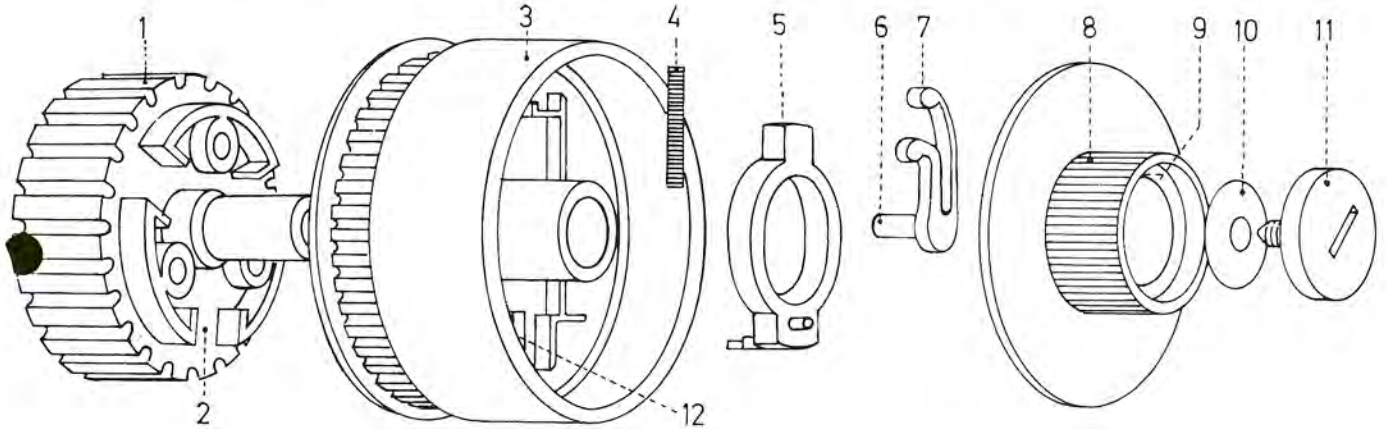

Fig. 67

Refitting:

Turn balance wheel 3 (Fig. 67a), until hole 12 points downward. Hold balance wheel 3 (Fig. 67) in this position with one hand, and turn sprocket 1 (Fig. 67) with the other hand, until one cutout 2 (Fig. 67) in the sprocket is opposite hole 12 (Fig. 67a) in balance wheel 3.

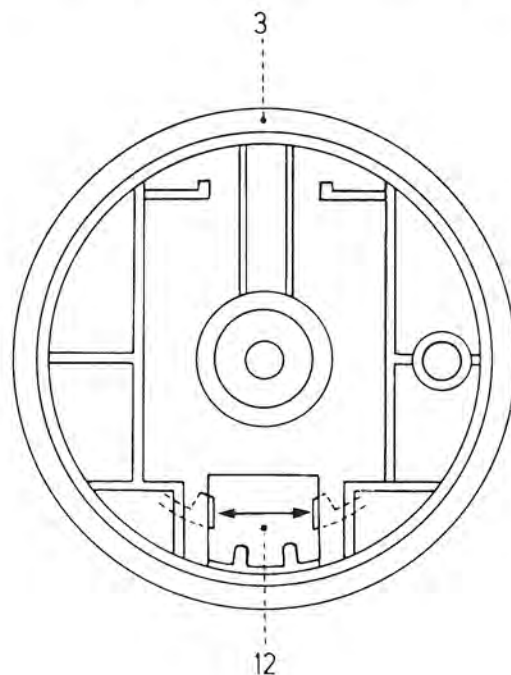

Fig. 67a



Place pressure spring 4 (Fig. 67b) onto boss 14 so that its rear end enters groove 13.

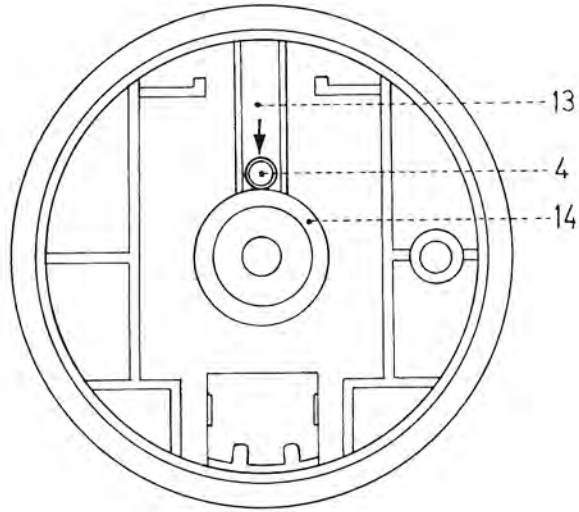

Fig. 67b

Slip clutch collar 5 (Fig. 67a) onto balance-wheel boss 14, and press it in. This will cause pressure spring 4 to be positioned vertically, and clutch collar 5 to be positioned as shown in Fig. 67c.

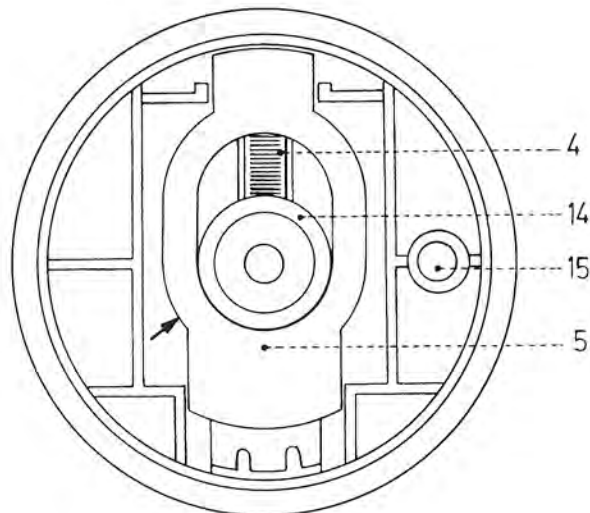

Fig. 67c

Insert fulcrum stud 6 of locking lever 7 (Fig. 67) into hole 15 (Fig. 67c) so that the locking lever is positioned as shown in Fig. 67d.

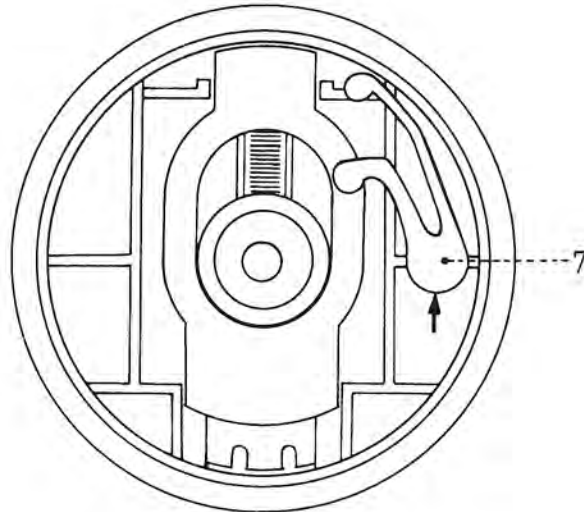

Fig. 67d

Insert balance-wheel release knob 8 (Fig. 67e) into balance wheel 3 with its square mark 9 pointing upward. In order to snap into place, balance-wheel release knob 8 must be turned right and left for abt. 5 mm.

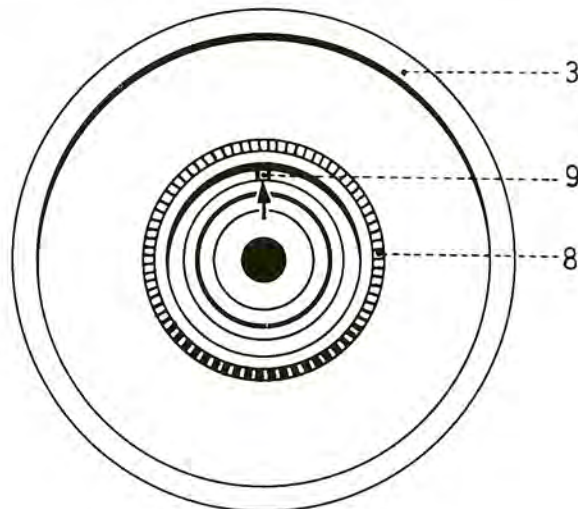

Fig. 67e

Screw on screw 11 (Fig. 67) with washer 10. Hold balance wheel 3 fast and turn balance-wheel release knob 8 in the direction of machine rotation, until you hear it snap into place.

Check the proper functioning of the balance-wheel release knob by engaging and disengaging it.

M.F.

## 68. Exchanging the Cam Stack

This job should only be carried out by a mechanic who has been trained at the Pfaff factory. It takes 30 to 45 minutes.

### Removing the Old Cam Stack

Remove the presser foot and the arm cover. Turn the master selector dial to a position between 0 and 4 and set the needle at its left position. Turn the pattern length wheel to  Push the second blindstitch button. Turn the balance wheel until the needle rises at the left and its point is flush with the top surface of the needle plate (Fig. 68a).

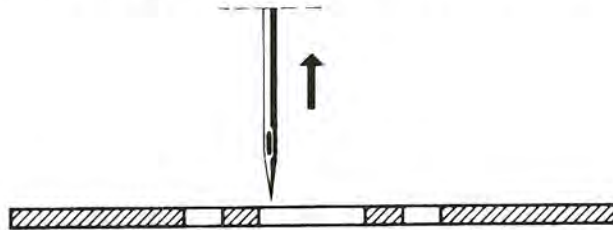

Fig. 68a

Do not turn the balance wheel any more. Disengage the blindstitch button. Turn out the two left screws 24 of the automatic unit (Fig. 68b). Turn the two right screws 24 out by four to six turns. Loosen screw 21 and turn eccentric stud 22 so that the lobe of the eccentric points upwards. Lift the left end of the automatic unit and turn cam stack 23 until it can be pulled out.

### Inserting the New Cam Stack

Insert the cam stack with the complete eccentric stud into the automatic unit and turn the stud 22 until the lobe of the eccentric points upwards. Slightly tighten screw 21. (Fig. 68b). Replace the automatic unit.

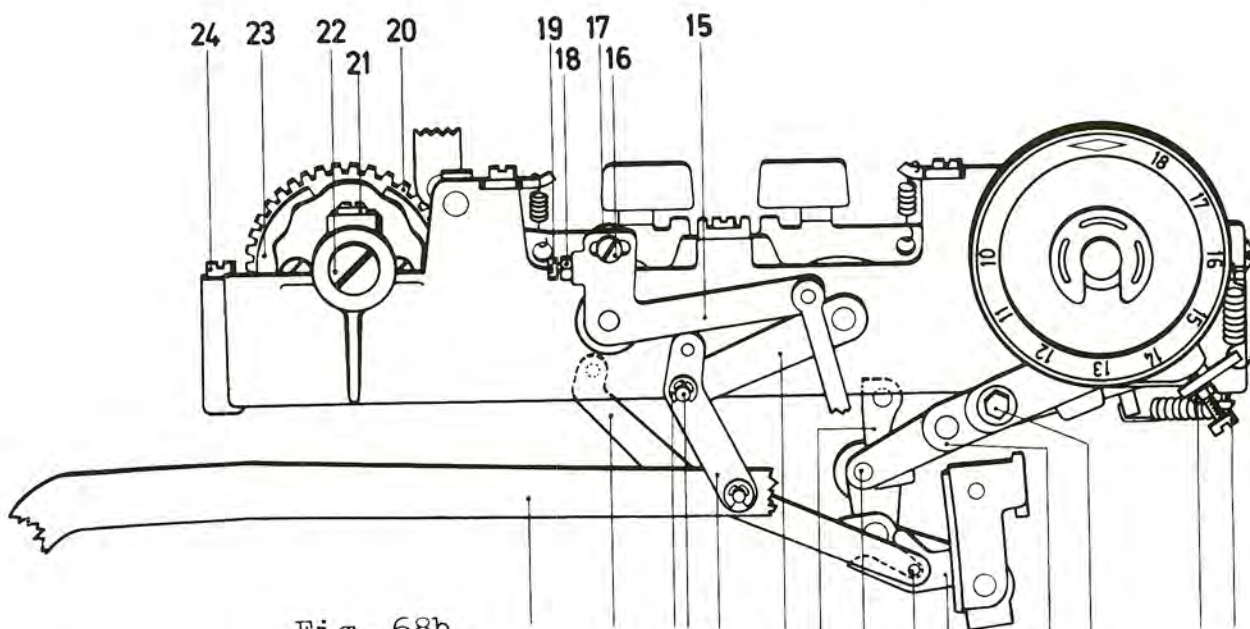

Fig. 68b



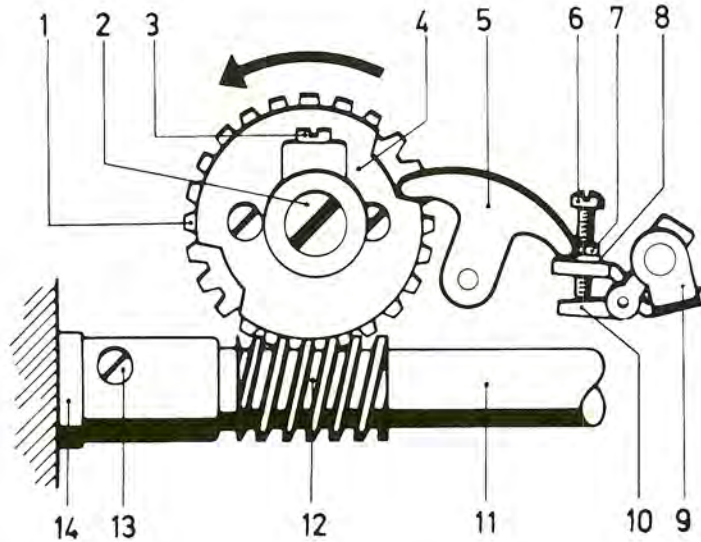

Fig. 68c

Push the second blindstitch button. Lift the automatic unit by abt. 5 mm and turn cam stack 4 counter-clockwise until feeler finger 5 is positioned exactly at the point where the lobe of blindstitch cam 4 begins (Fig. 68c). Replace the automatic unit and screw it down with four screws.

Adjust the play between worm and worm wheel as follows: Loosen screw 3 (Fig. 68c). Insert special spanner No. 106 300-306 into the slot of eccentric stud 2 and turn it counter-clockwise until there is no clearance between worm 12 and worm wheel 1. At the same time push cam stack 4 forwards or backwards until each feeler finger 5 contacts only the cam opposite. Securely tighten screw 3.

The ascending needle must begin to move from left to right when the needle point is flush with the top surface of the needle plate (Fig. 68d).

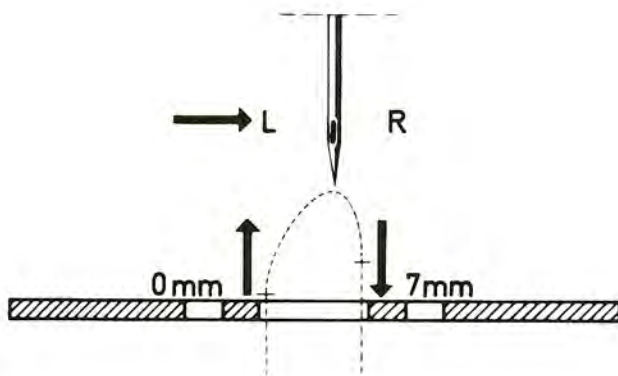

Fig. 68d

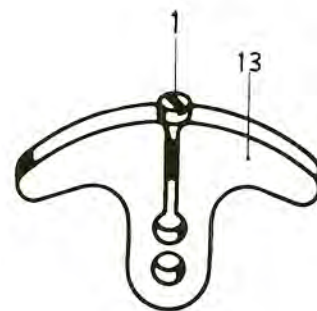

Fig. 68e

If it does not, loosen the three screws 13 of the worm (Fig. 68c) and turn the balance wheel backwards until the point of the needle is flush with the top surface of the needle plate when the needle ascends on the left of its throw (Fig. 68a). Turn worm 12 (Fig. 3) forwards until feeler finger 5 is exactly at the point where the lobe of blindstitch cam 4 begins. Secure worm 12 in position with the three screws 13, making sure it has no play. Check the needle sideways motion of the automatic mechanism (Fig. 4) and again move the ascending needle to the left of its throw (Fig. 68a). To double-check this setting, see whether the sideways needle motions of the automatic mechanism and of the zigzag mechanism coincide. For this purpose, disengage the blindstitch button. Turn the master selector dial to "8" and set the needle at its central position. The needle must now be positioned at the left of the needle plate slot (Fig. 68a). If the needle is at the right, the following adjustment is to be made:

Loosen the three screws 13 of the worm (Fig. 68c). Turn the balance wheel until the point of the ascending needle on the left of its throw is flush with the top surface of the needle hole (Fig. 68a). Push the blindstitch button. Turn the master selector dial to "4" and set the needle at its left position. Turn worm 12 forwards until feeler finger 5 is exactly at the point where the lobe of blindstitch cam 4 begins (Fig. 68c). Tighten the three screws 13 of the worm, making sure it has no play. Check the needle sideways motion. If the needle throw is not centered in the needle plate slot, adjust by turning screw 6 (Fig. 68c). Remove the black button with the hemstitching symbol and push on the new button with the overlock-stitch symbol.

#### Adjusting the Household Overlock Stitch

Attach the normal zigzag foot and make the machine ready for sewing.

Push the button with the overlock-stitch symbol. Turn the master selector dial to "4" and set the needle at the left position. Loosen nut 18 and turn screw 19 out by abt. two turns (Fig. 68b). Loosen screw 16 and tighten it again lightly. Sew the household overlock-stitch seam. When making the overlock stitch the needle must always stitch into the material in exactly the same spot during both forward and reverse sewing. If adjustment is required, turn in screw 19 until this requirement is met. Then tighten both screw 16 and nut 18 very firmly.

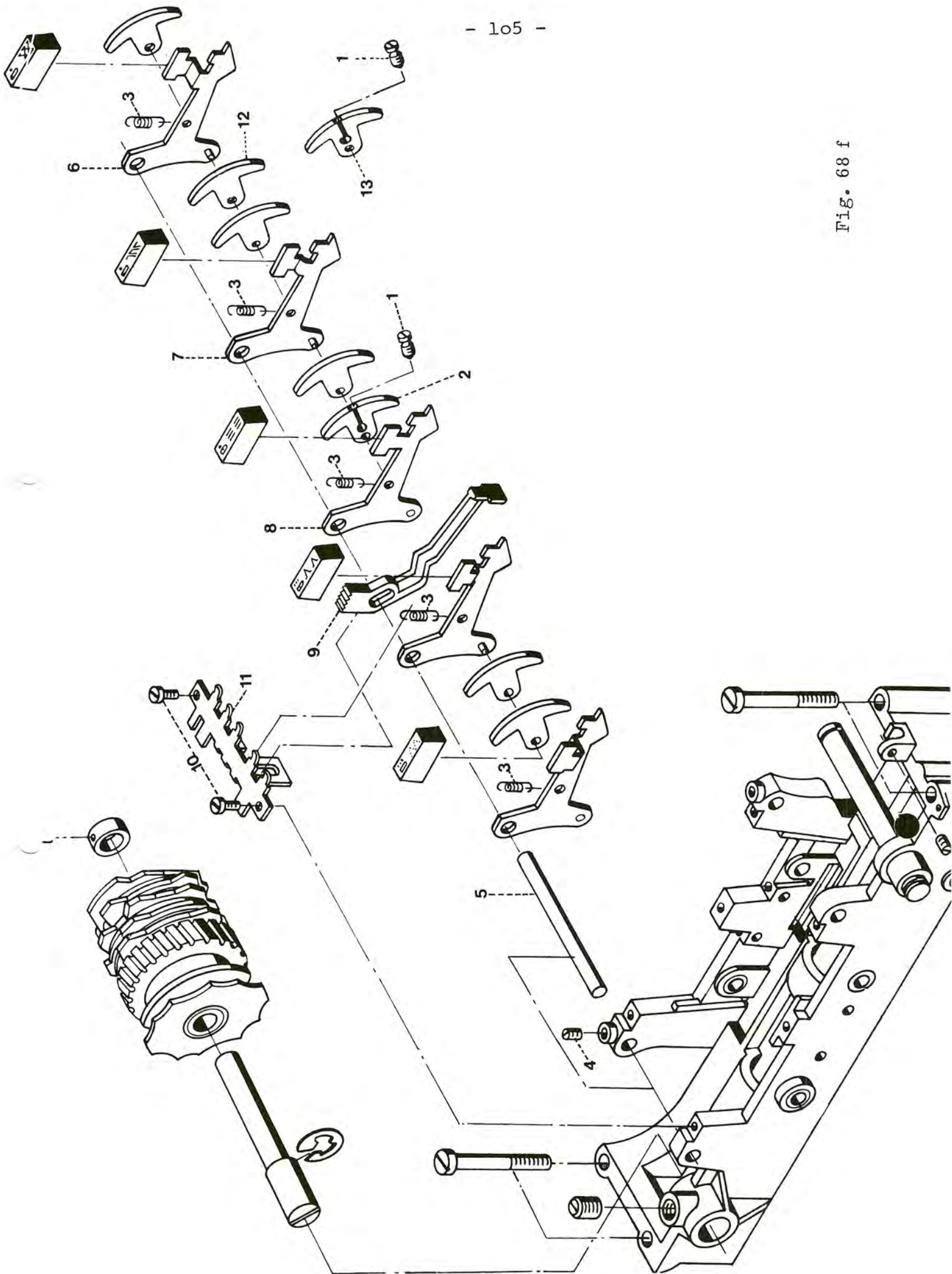

Fig. 68 f



### Adjusting the Honeycomb and Triple-Straight Stitches

Simultaneously push the buttons of the elastic and triple-straight stitches. Turn the master selector dial to "4" and set the needle at its left position. Turn out screw 1 of feeler lever 13 by abt. two turns (Fig. 68f). Sew the honeycomb stitch.

When sewing the honeycomb stitch the needle must always stitch into the material in exactly the same spot during both forward and backward sewing. If adjustment is required, turn in screw 1 until this requirement is met. To double-check this setting, set the needle at its central position and sew the triple-straight stitch alone.

### Overedge-stitch Seam

The triangles of the overedge-stitch should be spaced from 0.5 to 1.5 mm apart, measured along their outer edge. To check this, push the button bearing the overedge-stitch symbol. Turn the master selector dial to "4" and set the needle at its left position. Sew the overedge-stitch seam.

If the spacing between triangles is much smaller or larger, this may be remedied by fitting an adjustable feeler lever (Fig. 68e).

### Fitting an Adjustable Feeler Lever

Disconnect the five springs 3 (Fig. 68f). Loosen screw 4 and push stud 5 forwards until the rear push-button levers 6, 7 and 8 and eraser button 9 are free. Take out the two screws 10 and pull the push-button guide 11 toward the right. Remove the complete push-button lever 6. Pull out feeler lever 12 and fit the new adjustable feeler lever 13 with screw 1. Replace the complete push-button lever 6. Push stud 5 backwards and tighten screw 4. Push push-button guide 11 back to its original position and secure it in position by tightening both screws 10. Reconnect the five springs 3.

Push the button bearing the overedge-stitch symbol. Turn the master selector dial to "4" and set the needle at its left position. Turn out screw 1 of feeler lever 13 by two turns. Sew the overedge-stitch seam.

Turn in screw 1 of feeler finger 13 until the triangles of the overedge-stitch seam are spaced from 0.5 to 1.5 mm apart, measured along their outer edge.

PHG/HTS  
Durlach, West Germany  
March 30, 1976