

# VIKING

## SEWING MACHINES

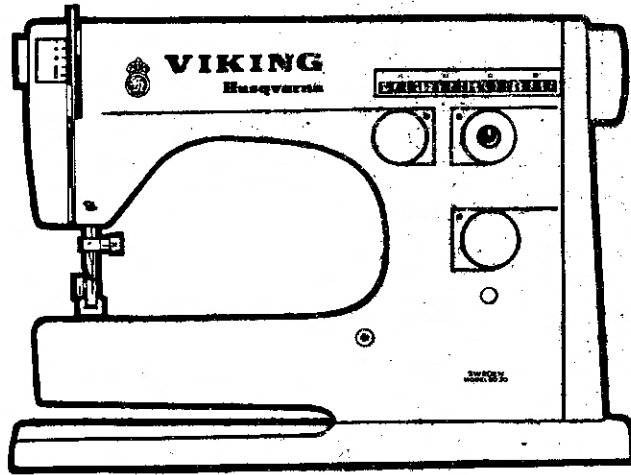

# SERVICE MANUAL

FOR MODELS

6030	6020	6010	6310	2000
1020	1030	1010	3310	3320

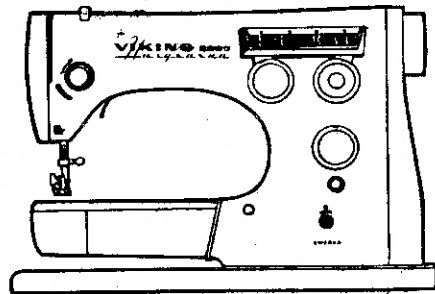
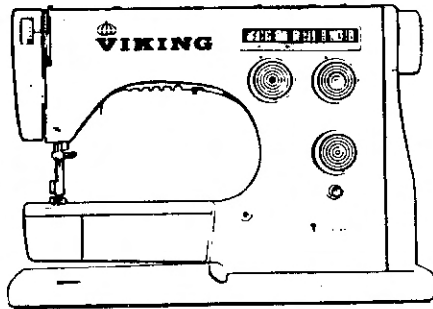

# INDEX

## CHAPTER I:

### THE 33 POINT CHECK FOR 6030 AND OTHER 30 SERIES MACHINES

Procedure for changing fixed cam

Procedure for changing stitch pattern  
mechanism

Procedure for changing stitch width  
mechanism

Procedure for changing stitch length  
mechanism

## CHAPTER II:

### THE 33 POINT CHECK FOR 6020 AND OTHER 20 SERIES MACHINES; 6010 AND OTHER 10 SERIES MACHINES; MODEL 2000 AND FLATBED 6310, 3310 AND 3320 MODELS

## CHAPTER III:

### FURTHER SERVICE INFORMATION ON THE 6000 SERIES

## CHAPTER IV:

### TROUBLESHOOTING

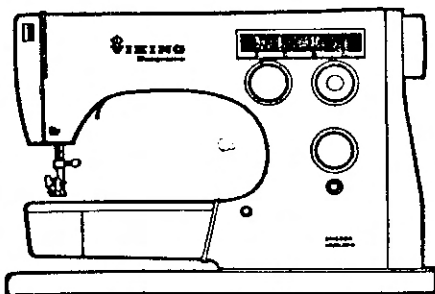

# Viking 6000 sewing machine

The first ten pages of this service manual explain the 33 functions you should check every time you have a Viking 6000 series machine for adjustment.

All 33 items can be checked in 15 minutes, and should be inspected in the exact order as listed below and on pages 2 through 10.

First, inspect the entire machine, making a notation (on a separate piece of paper) of those functions which you think will need to be adjusted. Then, make the necessary adjustments in the order in which they were found!!

EXAMPLE: If a machine makes loose stitches on the underside of the fabric, do not immediately assume it has a loose upper tension. The real problem could also be located in paragraphs 3, 19 or 22.

## CONTENTS

- |   |   |
|---|---|
| 1. Needle plate                           | 18. Shuttle clearance (front to back)   |
| 2. New needle                             | 19. Timing of rotation the shuttle  |
| 3. Remove lint in shuttle                 | 20. Height of needle bar  |
| 4. Winding of bobbin                      | 21. Timing of needle swing on zigzag  |
| 5. Bobbin case tension                    | 22. Timing of feeding action  |
| 6. Upper tension                          | 23. Needle bar frame freedom to zigzag  |
| 7. Takeup spring travel                   | 24. Left hand needle position   |
| 8. Upper tension release                  | 25. Equal needle clearance at ends of slot  |
| 9. Alignment of feed dog                  | 26. Center needle position  |
| 10. Feed dog centering left-to-right      | 27. Retraction of stitch width cam follower   |
| 11. Feed dog centering fore and aft       | 28. Retraction of auto stitch-length follower   |
| 12. Drop feed                             | 29. Fore and aft position of auto length follower                                     |
| 13. Height of feed dog                    | 30. Fore and aft position of width cam follower                                       |
| 14. Presser foot alignment                | 31. Setting of the overall zigzag width   |
| 15. Presser bar (foot) height             | 32. Equalize auto fore and aft stitch lengths   |
| 16. Centering needle in slot fore and aft | 33. Equalization of the forward and reverse<br>stitch lengths when making buttonholes |
| 17. Needle to hook distance fore and aft  |   |

## PROCEDURE FOR LOCATING SERVICE CORRECTIONS

- 1st. MAKE A VISUAL INSPECTION OF THE ENTIRE MACHINE IN THE FOLLOWING ORDER BEFORE MAKING ANY ADJUSTMENTS
- 2nd. WRITE DOWN ALL ADJUSTMENTS WHICH NEED TO BE MADE
- 3rd. THEN, MAKE THE NECESSARY ADJUSTMENTS IN THE ORDER IN WHICH YOU FOUND THEM

1. Remove and inspect the needle plate, clean out lint under needle plate and between the rows of teeth in the feed dog; reinstall needle plate.
2. Insert a new Viking sewing machine needle

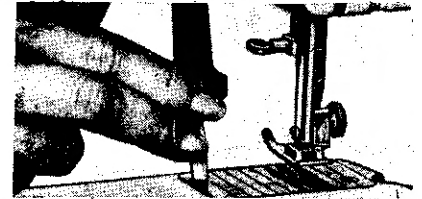

3. Remove thread or lint which might be wrapped around the center post of the shuttle.
4. See that the bobbin is properly wound.

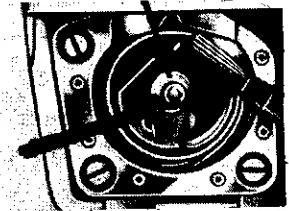

5. Clean any packed lint from inside of bobbin case.

Thread should pull smoothly from the bobbin case with a slight tension.

Bobbin case tension can be adjusted with this screw.

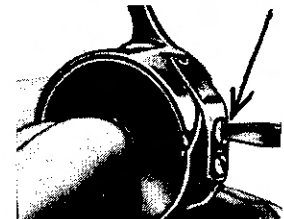
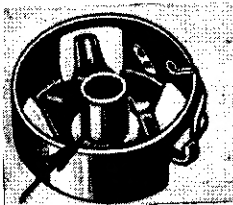

6. With presser foot lowered, the upper thread should pull smoothly through the upper tension. It should have a little more tension than the bobbin case thread.

NOTE: Viking sewing machines operate with a lighter tension than most other brands of sewing machines. To align red dots pull off cap B, align and snap on.

Upper tension is adjusted by turning dial (B)

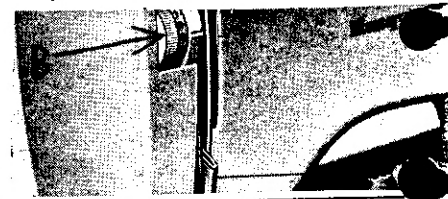

7. When sewing, the takeup spring should stop traveling when the needle starts to enter the cloth and the thread should be forming a loop at the eye of the needle

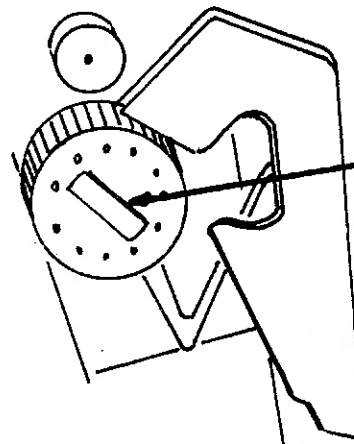

White knob adjusts amount of travel of takeup spring.

8. The upper tension should release when the presser foot is raised. (The tension disc should be loose).

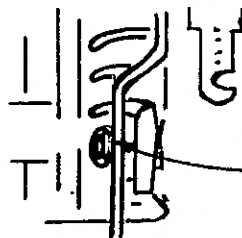

This eccentric reached from front adjusts tension.

9. The feed dog should line up with the slots in the needle plate.

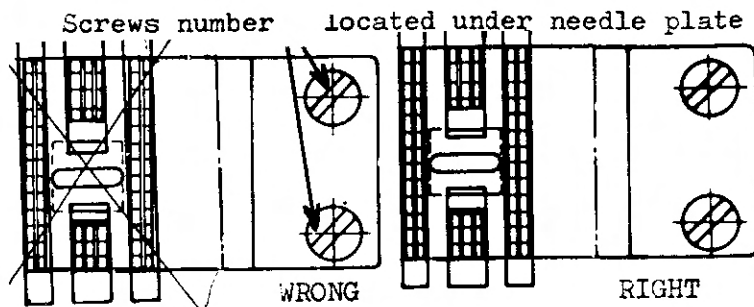

10. Does the feed dog need to be moved to the left or to the right? Set screw #1 allows this to be done.
11. The feed dog should not touch the front or back ends of the needle plate slots when sewing with longest stitch length. CHECK IN FORWARD and REVERSE sewing. Re-position as needed using clamp screw #2 BUT, ONLY AFTER CHECKING PAR. 33.

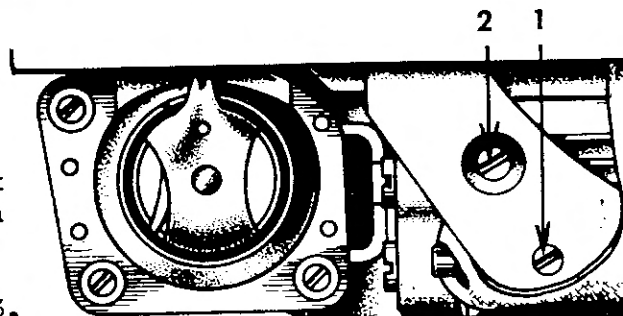

12. Does the drop-feed work O.K? After activating the drop feed, the feed teeth should raise or lower after making one revolution of the handwheel. Screw #3 adjusts the drop feed function

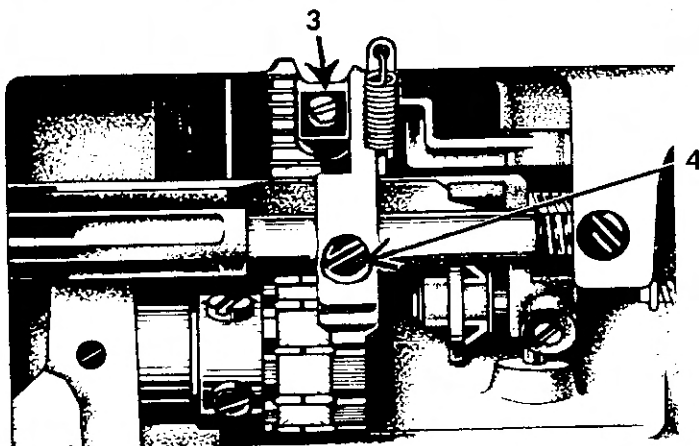

13. Feed dog teeth should rise 1mm above needleplate when feed dog is at its highest position. Clamp screw #4 allows you to raise or lower the height of the feed dog.

14. The presser foot should be in alignment with the rows of teeth in the feed-dog. Set screw #5 allows the presser bar to be re-aligned.

15. Is presser foot set at the proper height? To check this, drop the feed-dog and lower the presser bar so presser foot sits on the bare needleplate. The lifter lever (b) should then have a little "play" in it before it would start to raise the presser foot.

If not, loosen set screw #5. Hold presser foot firmly against needleplate as you move foot lifter lever #6 upward a short distance, thereby raising the presser bar lifter bracket #7 to a higher position on the presser bar. Re-tighten set screw #5.

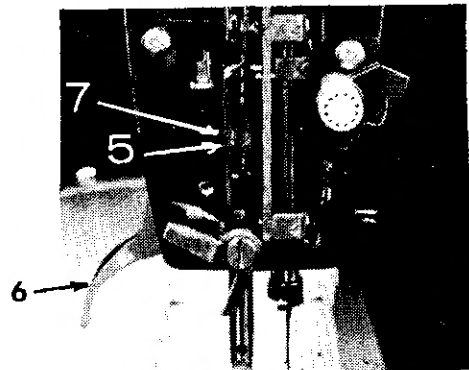

PRESSER FOOT LIFTER LEVER

16. The needle should clear both the front edge and the rear edge of the needle hole slot in the needleplate.

If necessary, loosen screw #8 and move the upper end of the needle bar carrier in the direction of the arrows (↔) until the needle is centered (from front to back) in the needleplate slot.

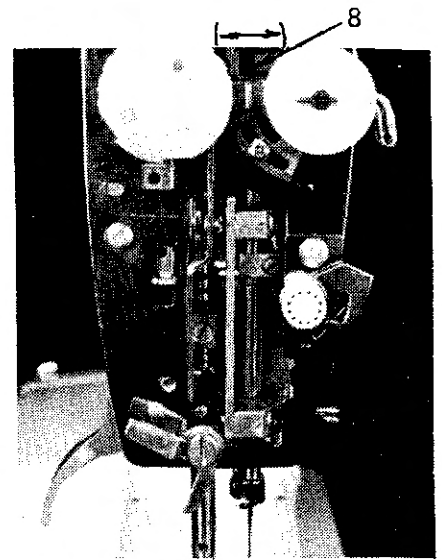

17. Remove bobbin case. Turn hand-wheel until face of hook point passes behind the needle.

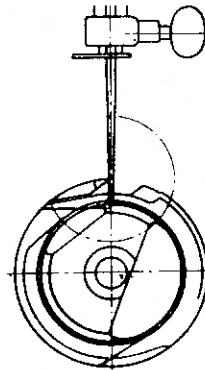
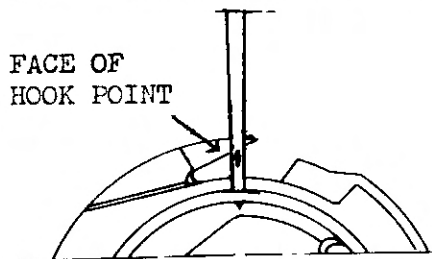

There should be little or no space (measured from front to back) between the needle and front side of the hook point face.

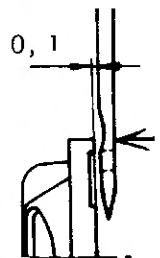

TO CHECK: Press shuttle post to rear with one finger, and use screwdriver to deflect needle to the rear against face of hook point.

ANOTHER CHECK: Run machine and if setting is right you will hear the needle rubbing against the hook and when you press on the center post of the hook it should not be heard.

TO ADJUST THIS SPACING: Remove shuttle cover, shuttle and shuttle driver and add or remove spacer washers behind driver as necessary.

18. Check the position of the shuttle cover, it should be parallel to the face of the shuttle driver and also far enough away from the driver so that there is proper clearance space. The shuttle should be free to move in and out.

Remove screws #9 and install gauge #41 11 649 in place of the shuttle, then loosen set screws #10 which hold the three mounting posts in position, then with the fingertips of one hand, simultaneously push the shuttle cover inward at points #A so the shuttle cover rests upon the face of the gauge. Tighten the three set screws #10. Remove shuttle cover and install the shuttle in place of the gauge.

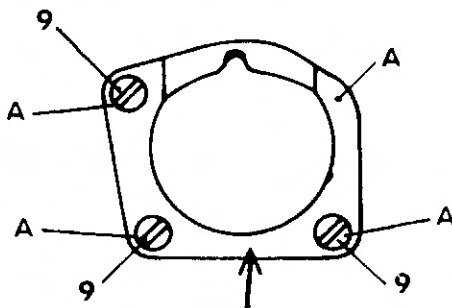

SHUTTLE COVER

FIG. 1

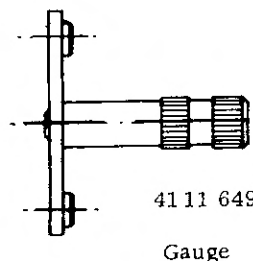

FIG. 2

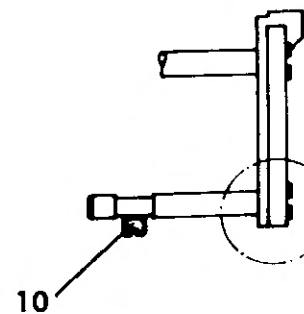

FIG. 3



19. CHECK THE TIMING OF ROTATION OF THE SHUTTLE WITH RELATION TO THE TAKE-UP LEVER. Set the stitch width knob to 0 position and the pattern selector at the zig-zag symbol. Turn handwheel until the take-up lever is at its lowest position. Fig. 1. The tip of the shuttle, should be at it's lowest possible position Fig. 2. (at six o'clock). If not, remove the access plate under the base of the machine and loosen the three set screws #11, starting with the silver one then the two black ones. Grasp the handwheel with one hand as you loosen the last set screw, retaining hold of the handwheel, turn the shuttle "ahead" or "back" as required. Retighten one set screw and recheck, (the one set screw must be one of the black ones as the silver screw is a locking screw). Then tighten the remaining black and silver screw in that order.

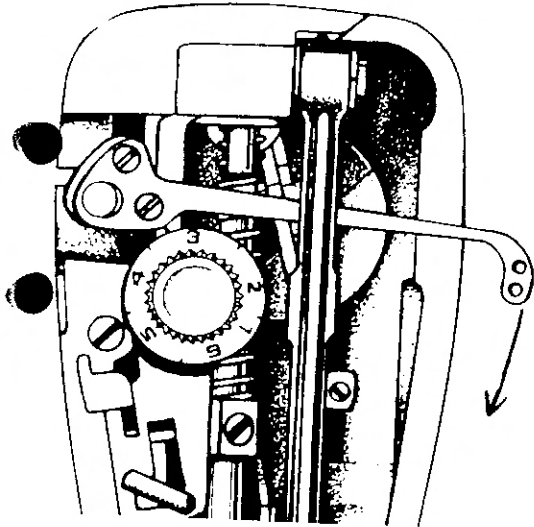

FIG. 1

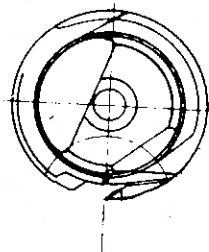

FIG. 2

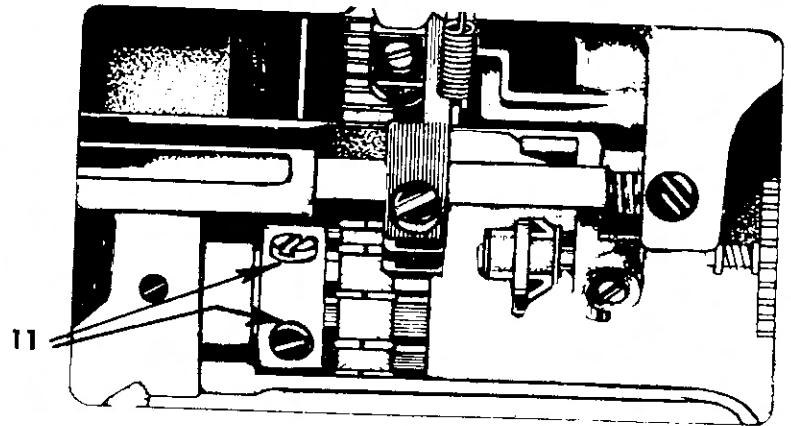
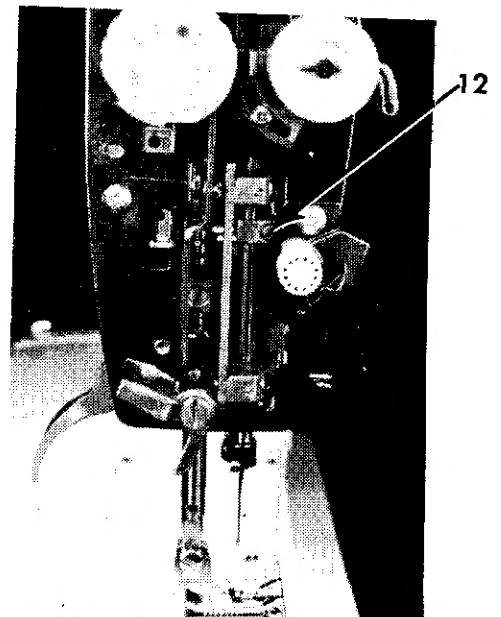
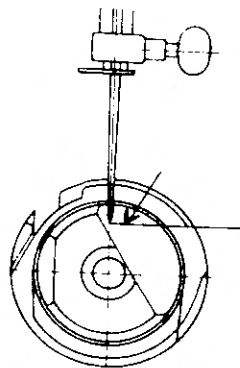
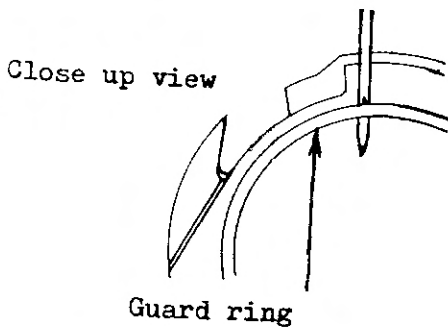

FIG. 3

20. Check height of needle bar. Make sure you have the right needle in the machine!

When the needle is in it's lowest position the upper portion of the needle eye should be visible above the shuttle guard ring.

Clamp screw #12 allows you to raise or lower the needle bar.





21. TIMING NEEDLE SWING:

Set the pattern selector at the zig-zag symbol and the stitch width knob at position 2. Turn the handwheel and watch needle swing, it should swing sideways when it is out of the cloth. Back off the screws #13 Fig. 1. Grasp pattern cam #A, Fig. 1 in the right hand and turn it in the direction of the arrow. Turn the handwheel with the other hand until the cam follower rides a lobe on the cam, see Fig. 1. Hold worm gear 40 11 808 in position with a finger so that the pattern cam does not alter position and turn the handwheel forwards until the needle reaches its lowest position. Tighten the screws #13.

Should the position of the worm gear prevent access to the screws, proceed as follows: Turn pattern cam #A Fig. 1 in the direction of the arrow while turning the handwheel forwards until a screw on the worm gear becomes accessible for tightening.

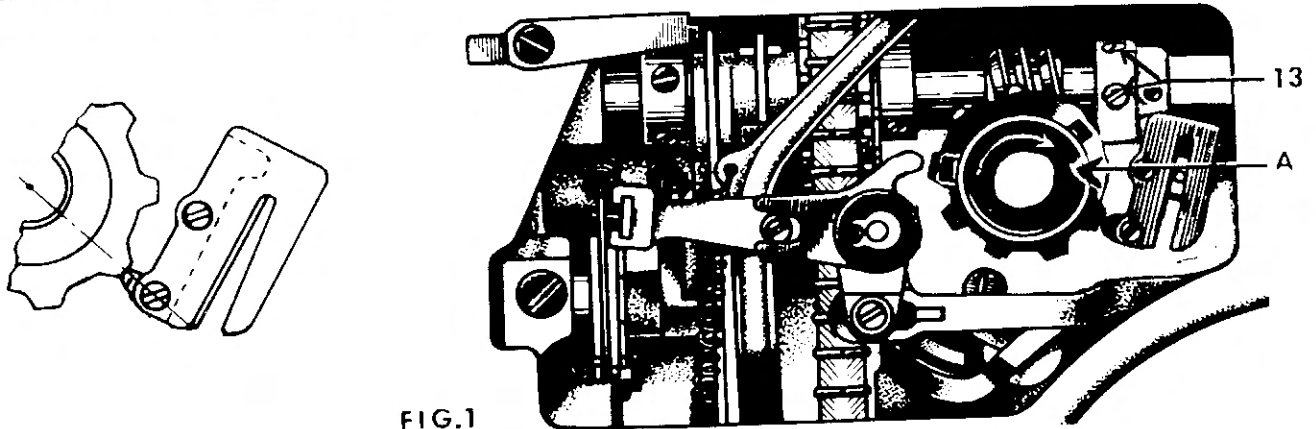

FIG. 1

22. The feed dog should stop feeding at the proper moment. Check this by setting the stitch length on 4, the stitch pattern mechanism on the buttonhole symbol and the stitch width on 0.

Models 6030, 5230, 3230 and 1030. When the needle enters the cloth, the feed dog teeth should have completed their horizontal travel and have dropped and almost reached the level of the top of the needle plate, and should be dropping vertically.

To adjust the timing of the feeding action, loosen the set screw on the feed eccentric #14. Hold feed eccentric in position and turn handwheel forward or backward as necessary. Retighten set screw.

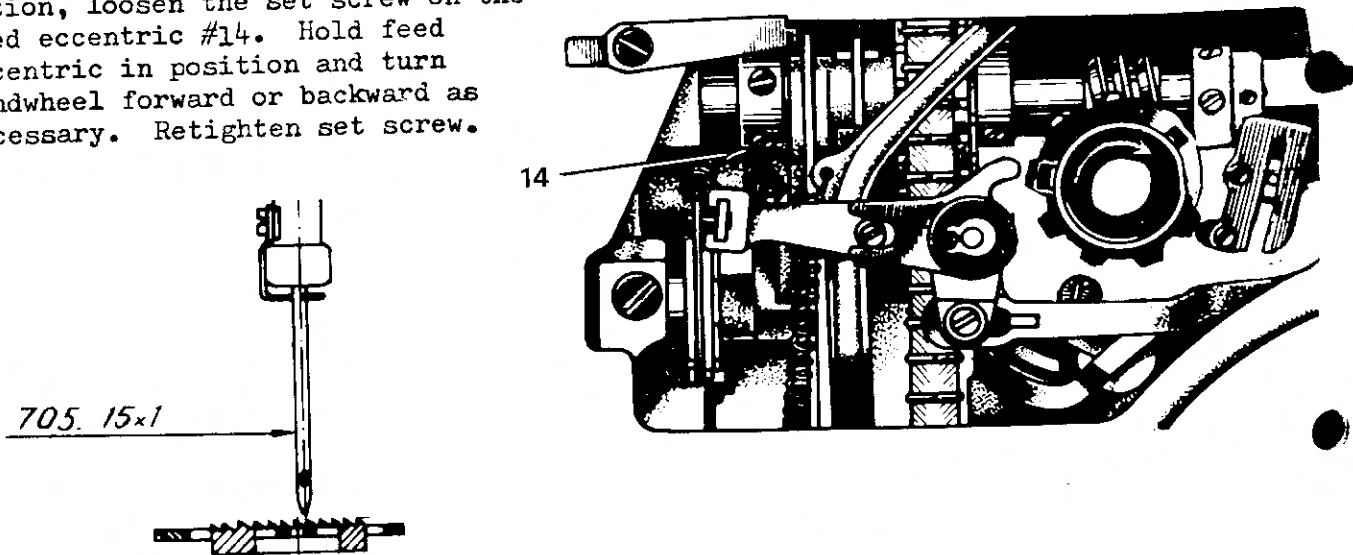

FIG. 2

23. The needle bar frame should not be unduly restricted. Set the pattern selector at the zig-zag symbol, remove cam and turn stitch width knob to widest position (4). Turn the handwheel until the needle has just entered the needle plate on the right side. The needle should be just rubbing against the needle plate and when pushed to the left it should bend slightly when against the needle plate. To obtain the right amount of clearance turn screw #15 Fig.1 , until proper clearance is reached.

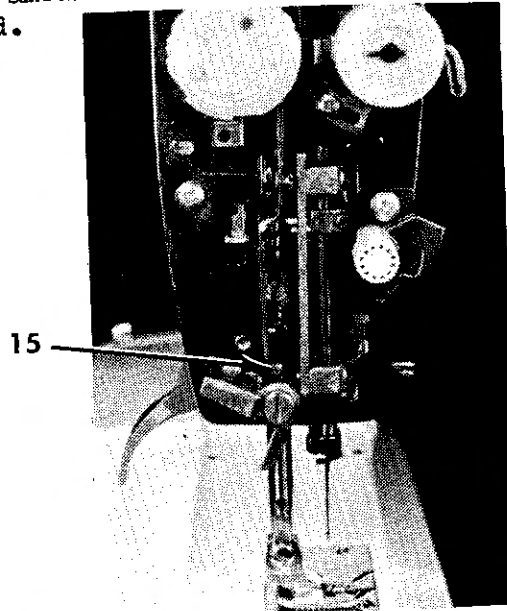

FIG.1

THE NEXT THREE ARE THE MOST IMPORTANT ADJUSTMENTS TO BE CHECKED

24. Check the "left hand needle position".

Set selector knob to left needle position.

Set zigzag width knob to #4 width.

Turn handwheel until needle bar is in its lowest position on the left side of zigzag.

Watch the needle bar (or needle), as you turn the width knob to 0 width.

If the needle bar (or needle) moves sideways when turning the width knob

from 4 to 0, adjust the eccentric #16 shown at right.

THIS SCREW IS TO BE TURNED CLOCKWISE ONLY!!

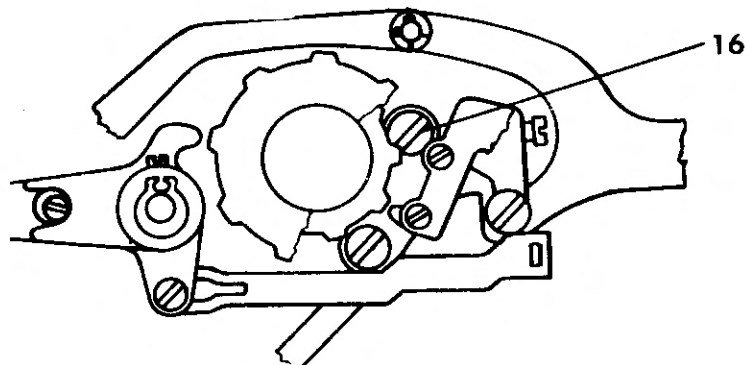

25. Set the pattern selector at the zigzag symbol and the stitch width knob at position (4). The needle should have equal clearance at both the right and left ends of the slot in the needle plate. Turn the handwheel until the needle point is level with the throat plate. Back off screw #17. Adjust the position of the needle bar frame by means of eccentric #18 until needle movement is centered in the throat plate, see Fig. 1. Tighten screw #17. Recheck step # 16 before tightening up screw #17.

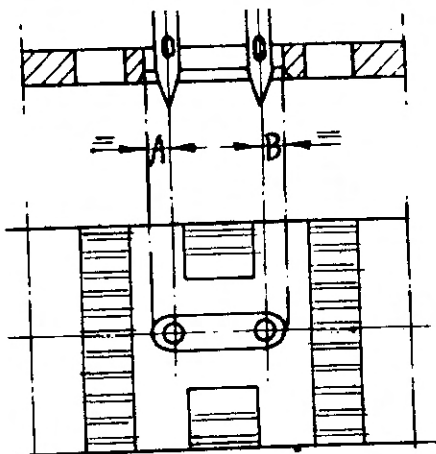
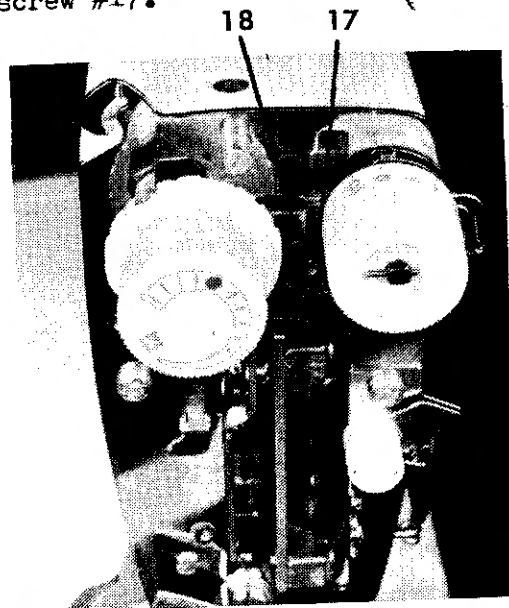
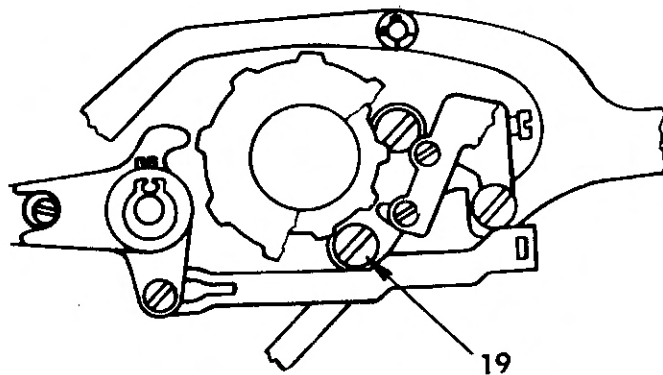
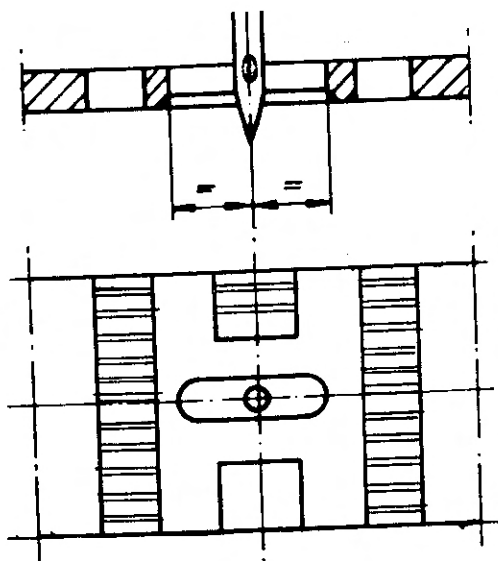

FIG. 1



26. THIS APPLIES ONLY TO MODELS WITH REVERSE BUTTONHOLE MECHANISM 6030 and 5230. Set pattern selector at the "buttonhole" (zig-zag) symbol and the stitch width knob at zero. Turn the handwheel until the eye of the needle enters the needleplate slot. If the needle is not in the center of the needleplate slot, adjust by turning the lower eccentric #19 (clockwise only) until the needle is centered (from left to right). This adjustment should be made with the machine running.



27. Check the retraction of the stitch width cam follower. Remove insertable camstack "A" and set pattern selector at zigzag symbol, set stitch width at #4, then turn handwheel until the needle is at its lowest lefthand position. The cam follower should be riding on the top lobe of the zigzag cam. Now turn the pattern selector knob so the two spots are in alignment Fig.1, the cam follower should retract away from the top of the lobe as indicated by distance A (not over .0005" or about the thickness of a postal card). If it does not retract, adjust eccentric #20, Fig.2. To see and reach eccentric #20 with a slim screwdriver, turn width dial to zero.

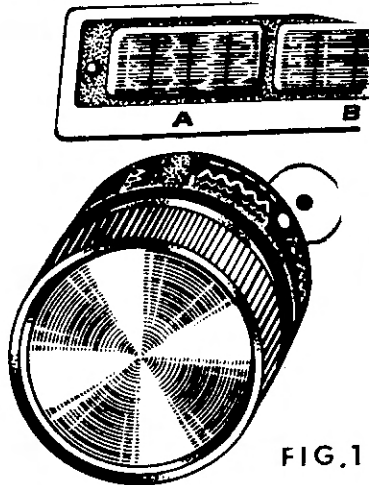

FIG.1

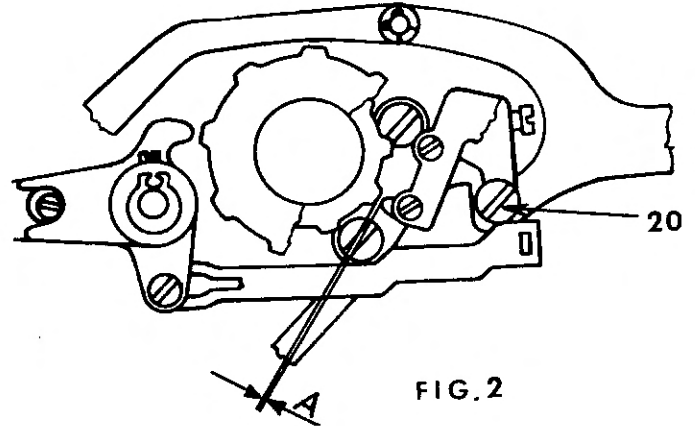
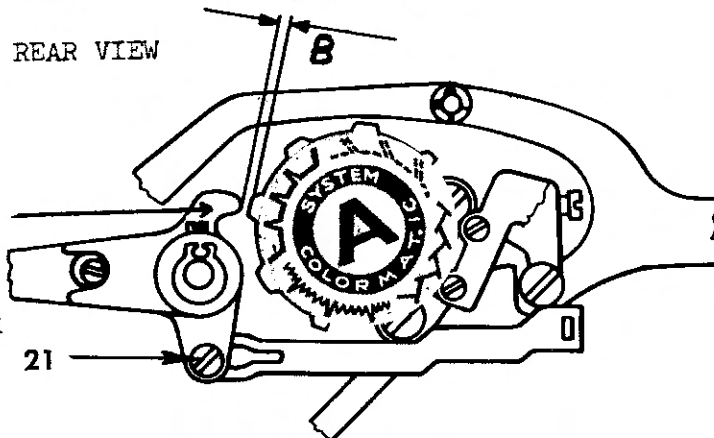

FIG.2

28. Check the retraction of the automatic stitch-length cam follower. Set the pattern selector on the yellow symbol, and turn the handwheel until cam follower rides on top of a lobe on the camstack "A". When you turn the pattern selector knob from yellow to the blue symbol, the automatic reverse stitch-length cam follower should retract away from the top of the lobe as indicated by " " (about .0005" or about the thickness of a postal card). Eccentric #21(at right) makes this adjustment, if necessary.

AUTOMATIC STITCH-LENGTH CAM FOLLOWER  
(Only operates on yellow or blue)



REAR VIEW

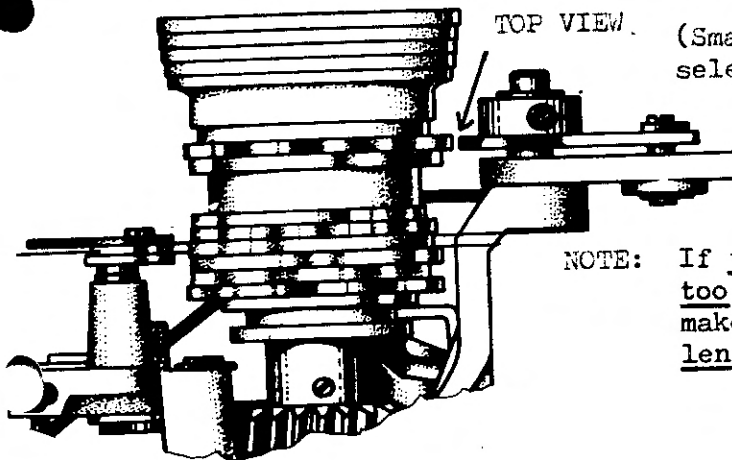

TOP VIEW.

(Small space should appear when turning selector knob yellow to blue symbol)

NOTE: If this cam follower retracts too much, the machine might not make stitches of sufficient forward length on yellow or blue symbols.

29. Check the positioning of automatic stitch-length cam follower.

Set pattern selector at yellow symbol and stitch width knob at 4, and turn handwheel until cam follower rides on top of a lobe on the cam. The cam follower should now be riding the middle of the 2.5 mm wide cam. Set screw #22 allows cam follower #23 to be repositioned.

Set screw #31 holds cam follower #32 onto a sleeve. If the spring clamp #33 is not installed in place, the cam follower could "wander" in the direction of the arrows. Be sure clamp spring is in place.

To reach set screw #22, open the upper arm end door and insert a long screwdriver through the upper arm of the machine.

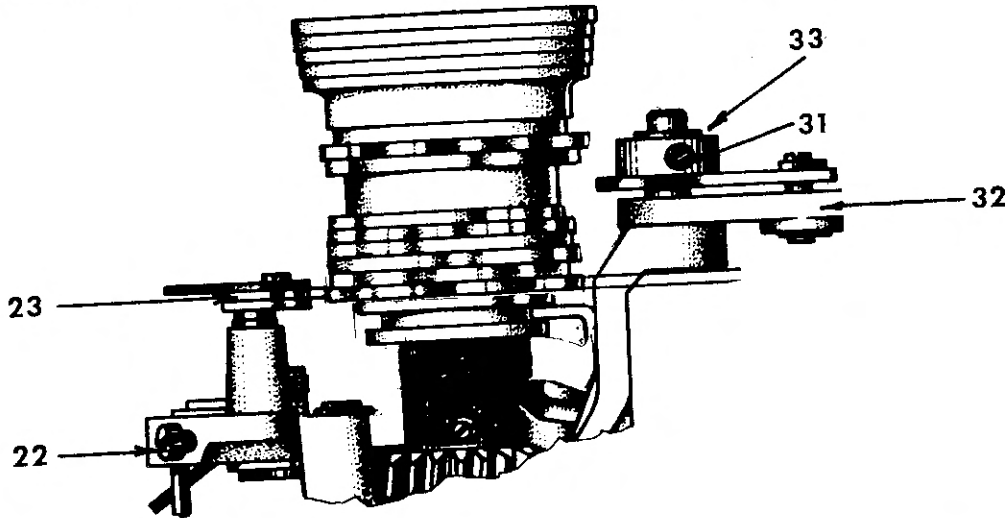

30. Check the position of the stitch width cam follower, with respect to the various cam surfaces, that is does the machine give you the stitch pattern you have selected?

Set stitch selector at zigzag symbol, and stitch width knob at position 4, and turn handwheel until width cam follower #24 rides on top of the lobe on the zigzag cam. Set screw #25 would allow you to position cam follower #24.

NOTE: Cam follower should ride on the center or slightly toward the rear side of the cam surface.

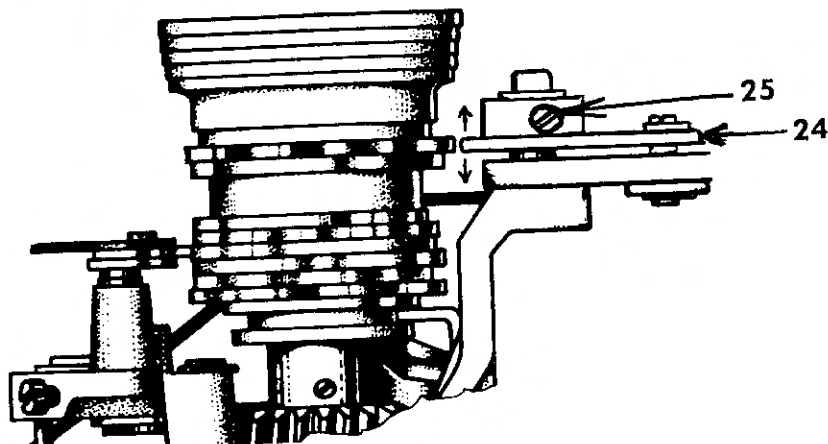

31. Check for straight stitching: Set pattern selector on zigzag symbol and stitch width knob on 0. Run the machine and at the same time watch the automatic cam follower for movement, there should not be any. If the cam follower moves turn screw #26 in a clockwise direction while running machine until it stops, then give it an additional one quarter turn.

Check the setting of the zigzag width. Set pattern selector at zigzag symbol and stitch width knob at position 4. Press the dropfeed button and insert a piece of paper between the presser foot and throat plate. Pierce the paper with point of needle in both left and right positions. Correct distance with point of needle in both left and right positions. Correct distance (zigzag width) is between 4.1 and 4.3 mm.

EXAMPLE: If zigzag width is too wide there might not be enough cutting space in buttonhole. X-ray view of rear of machine shows screw #26 which adjusts overall zigzag width. Turn to right to increase. Turn to left to decrease zigzag.

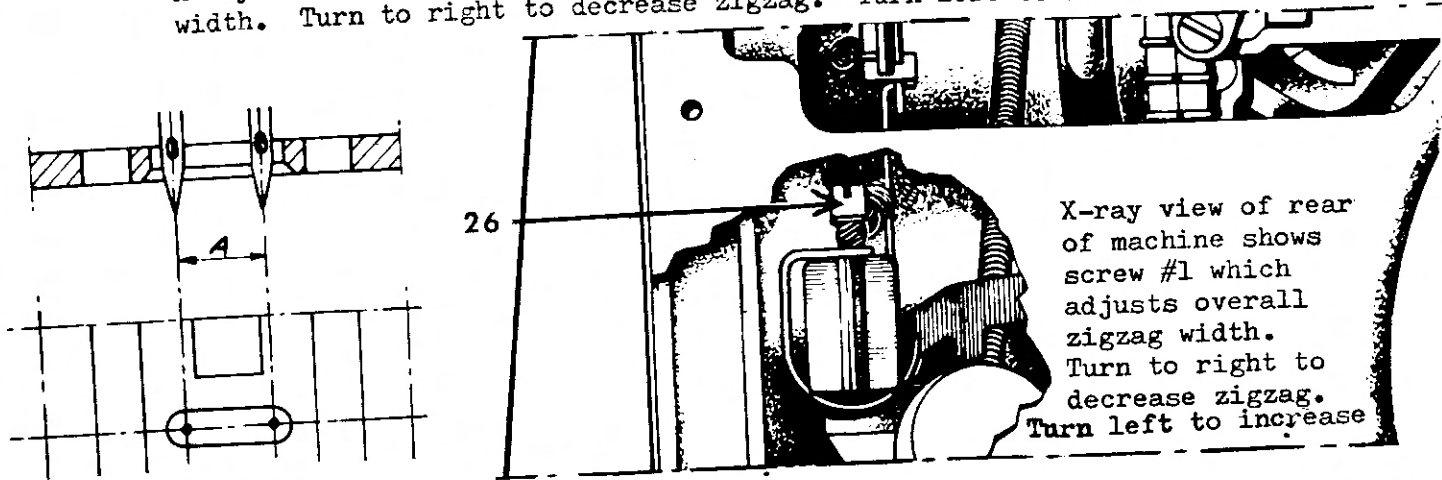
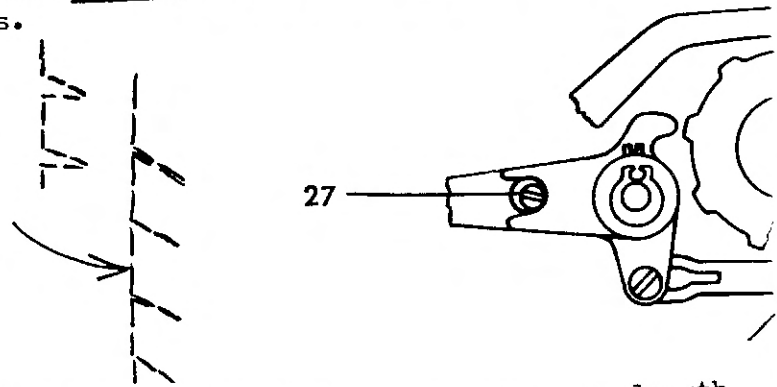

FIG.1

32. Check equalization of both forward and reverse stitch lengths when using the reverse automatic (yellow or blue) patterns.

You might first notice this if your A cam blue, blue, blue looks like this  
 instead of looking like this.  
 It merely means that the forward stitch length is longer than the reverse direction stitch length and eccentric #27 should be turned slightly.



For the ultimate in fine tuning, insert camstack "D", turn the selector, length and width knobs to "yellow" to get the "Turkish Hemstitch" pattern. Use a fine needle and fine sewing thread. Adjust eccentric #27 to get the best-looking stitch pattern as is possible. (NOTE: About 2½ width and 3 to 3½ length might work better with most thread).

33. Check equalization of both forward and reverse stitch lengths when making buttonholes.

Set machine for making buttonholes with selector at "zig-zag" and buttonhole" symbol; stitch length knob on buttonhole and stitch width knob on "0". Pull out the stitch width knob and turn to position number 1 and sew the first column of a buttonhole. Then turn the stitch width knob past number 2 and directly to number 3 position and sew the right hand column of the buttonhole. Compare the lengths of stitches and adjust with screw number 28 which is located by removing the cap from the reverse push button.

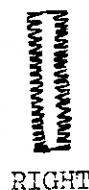
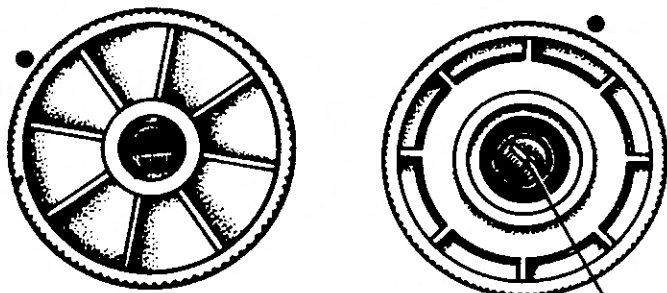
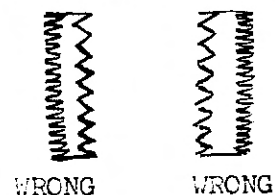
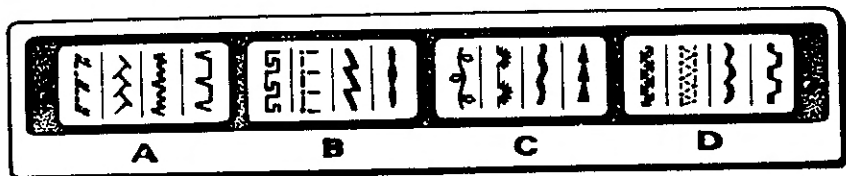

28

To remove the face plate on 6030, 5230, 3230 and 1030:

Move latch #29, Fig.1 down, then pull out on the bottom of the door and lift up.

To remove the back cover:

Remove face plate and then remove screw #30 Fig.1. Then remove the screw that is located under the spool pins.

To remove the tension face plate:

Remove face plate, turn presser foot pressure to the patch work symbol and then remove the four screws marked A.

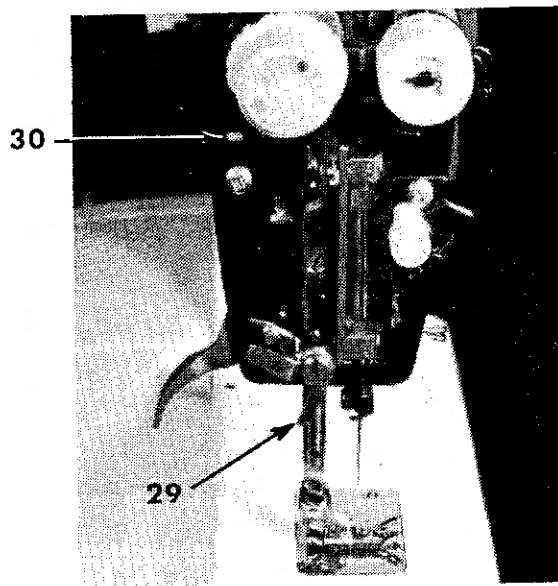

FIG. 1

## STEPS FOR CHANGING FIXED CAM

### Steps for removal:

1. Remove back cover of machine.
2. Turn Stitch Pattern Mechanism to left needle position.
3. Remove automatic cam follower #1.
4. Remove screw #2.
5. Remove fixed cam.

### Steps for replacing.

1. Install new fixed cam making sure bracket #4 is in groove on cam.
2. Replace screw #2.
3. Replace automatic cam follower.
4. Replace back cover.

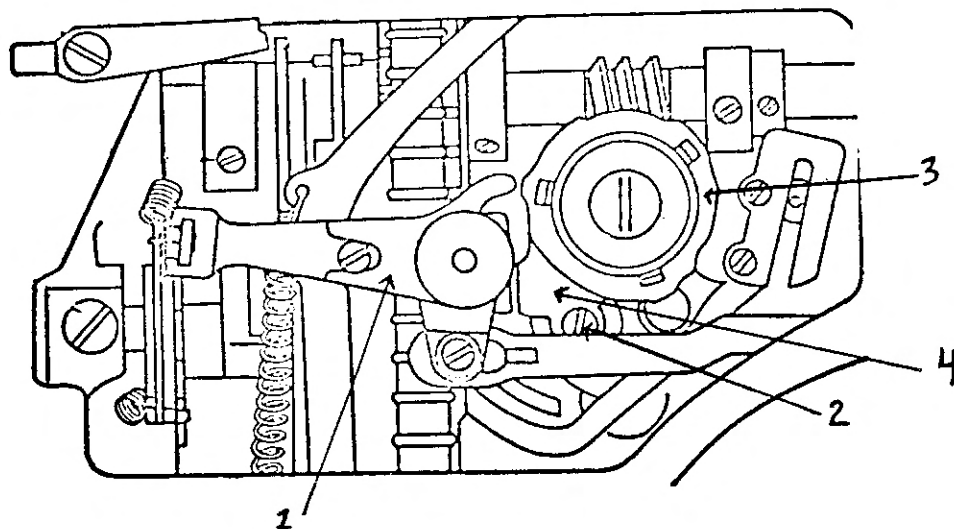



# 6030 STITCH PATTERN MECHANISM REMOVAL AND REPLACEMENT

## Steps for Removal

1. Remove screw holding lamp guard (screws # 2064-220-26).
2. Remove stitch pattern knob. (Remove disc and screw).
3. Remove lever arm (41 11 791) item # 1, fig. # 1 by removing clamp ring item # 2 fig. # 2.
4. Remove C washer from draw rod (41 13 419) item # 1 fig. # 2.
5. Remove spring from link rod (spring 41 14 002-01 link 41 14 032-01) item # 2 fig. # 1.
6. Remove screw # 2063-346-11 from stitch pattern mechanism item # 3 fig. 1.
7. Disengage fork lever arm (41 12 327-01) from stitch pattern mechanism to buttonhole mechanism by taking one screwdriver and lifting lever starting arm # 41 10 840 on stitch pattern mechanism and another screwdriver and at same time pushing fork arm down and right. Then after it is disengaged slide it to the left.
8. Remove draw rod from stitch pattern mechanism.
9. Remove stitch pattern mechanism complete.
10. Disconnect spring from stitch pattern mechanism.

## Steps for replacing stitch pattern mechanism

1. Insert stitch pattern mechanism and connect spring.
2. Replace fork lever arm (41 12 327-01).
3. Replace draw rod to stitch pattern mechanism.
4. Replace screw #2063 346-11 in stitch pattern mechanism
5. Connect link arm to draw rod and replace C washer.
6. Connect spring to link arm.
7. Replace lever arm (41 11 791) and replace clamp ring.
8. Replace lamp guard and screw.
9. Replace stitch pattern knob, screw and disc.

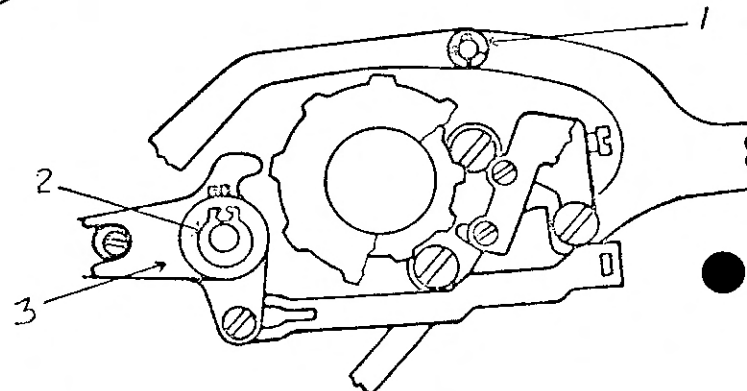
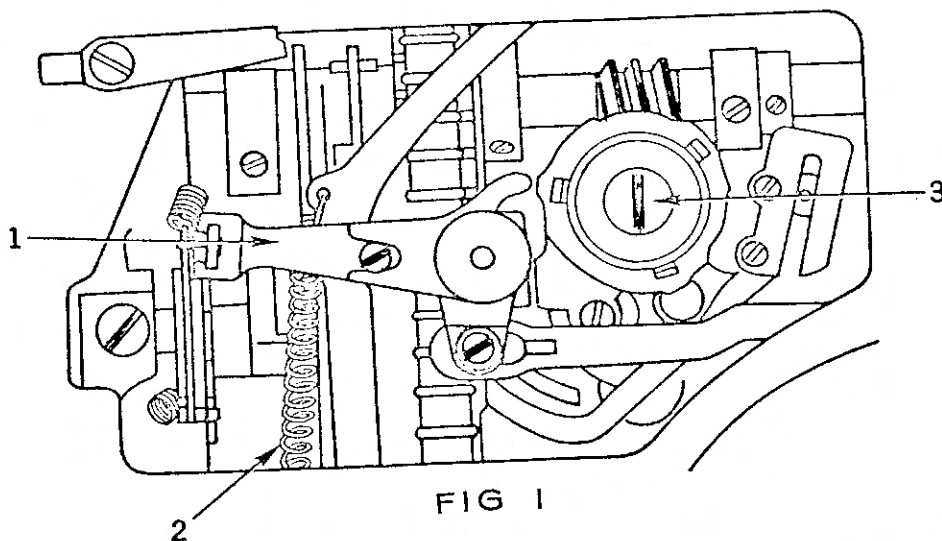

STEPS FOR REMOVAL

1. Remove back cover and belt guard.  
Pull out stitch width knob to engage buttonhole mechanism, then remove knob.
2. Remove lever arm item #3 fig. #1 by removing clamp ring item #2 fig. #1.
3. Remove screw located on front of machine behind stitch width knob.
4. Remove C washer item #1 fig. #1 and spring item #2 fig. #2 and remove stitch length arm.
5. Disengage spring from drop feed button to buttonhole mechanism.
6. Disengage fork lever arm (41-12-327-01) from stitch pattern mechanism to buttonhole mechanism by sliding it down and to the left. Then lift it up and out of the buttonhole mechanism.
7. Remove buttonhole mechanism through the handwheel end of machine

STEPS FOR REPLACEMENT

1. Place dropfeed spring on buttonhole mechanism.
2. Insert buttonhole mechanism through side of machine.
3. Place fork lever arm (41-12-327-01) into buttonhole mechanism.
4. Put screw holding buttonhole mechanism into place.
5. Place dropfeed spring into place.
6. Place fork lever arm (41-12-327-01) into place on stitch pattern mechanism.
7. Place link arm into place and connect spring and C washer.
8. Replace automatic cam follower item # 3 fig. #1 and clamp ring item # 2 fig. #1.
9. Replace stitch width knob.

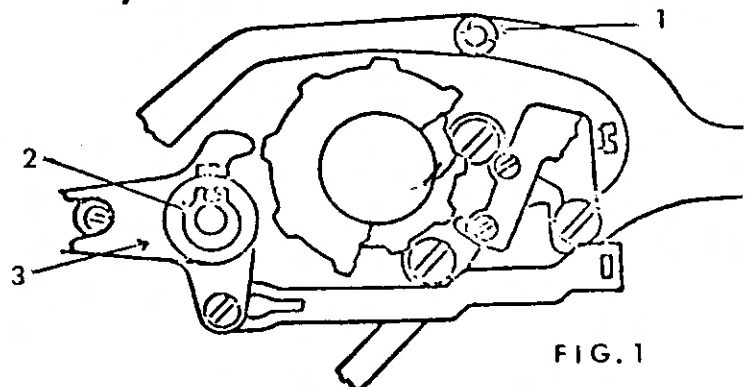
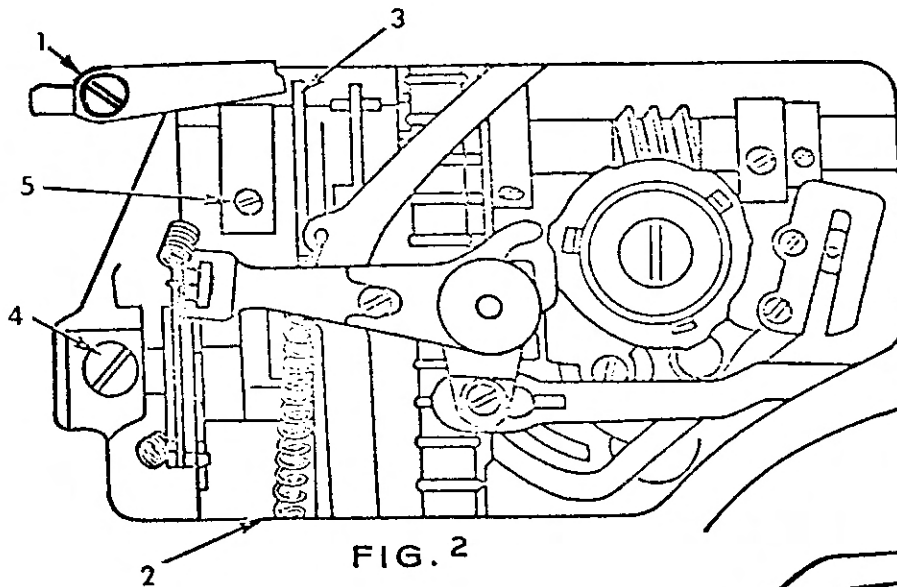

## 6030 Stitch Length Mechanism Removal and Replacement

### STEPS FOR REMOVAL

1. Remove back cover and the metal cover on the bottom of the machine.
2. Remove lever arm item #3 fig. #1 by removing clamping ring item #2 fig. #1.
3. Remove C washer item #1 fig. #1 and remove stitch length arm.
4. Remove stitch length knob.
5. Loosen screws item #1 fig. #2 then remove the two C washers item #2 fig. #2.
6. Loosen screws #5 fig. #3 and slide forked arm item #3 Fig. #3 toward needle and tighten screws.
7. Remove screw item #1 fig. #3 and disconnect spring.
8. Remove spring item #2 fig. 3 from link arm and remove link arm.
9. Remove stitch regulator fork item #3 fig. #3.
10. Loosen screw item #4 fig. #3 and remove stitch length mechanism.

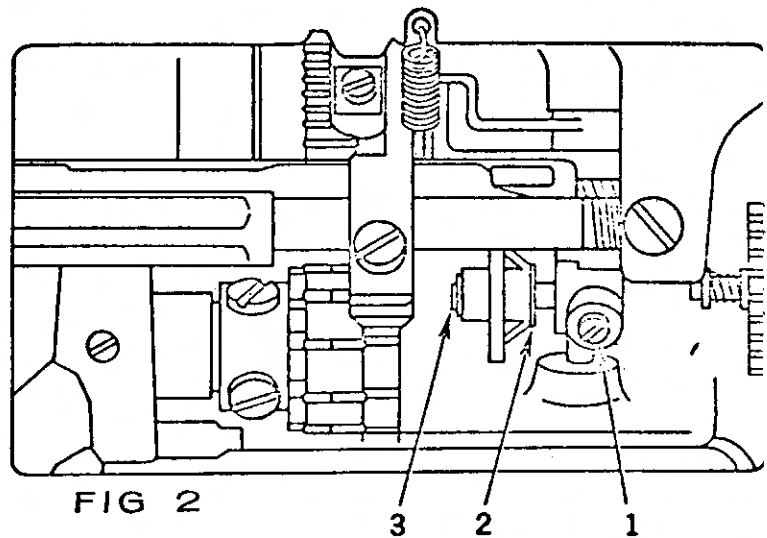
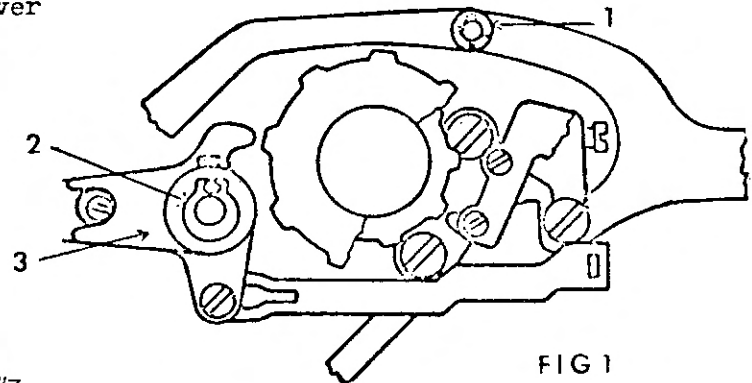

### STEPS FOR REPLACING STITCH LENGTH MECHANISM

1. Install new stitch length mechanism.
2. Replace the stitch regulator fork item #3 fig. #3.
3. Replace bracket and screw item #1 fig. #3 and reconnect spring to fork arm.
4. Replace shaft item #3 fig. #2 and C washer item #2 fig. #2.
5. Loosen screws item #5 fig. #3 and slide forked arm item #3 fig. #3 into position and tighten.
6. Replace stitch length arm and C washer item #1 fig. #1.
7. Replace lever arm item #3 fig. #1 and clamping ring item #2 fig. #1.
8. Replace covers.
9. Check machine by 33 points.

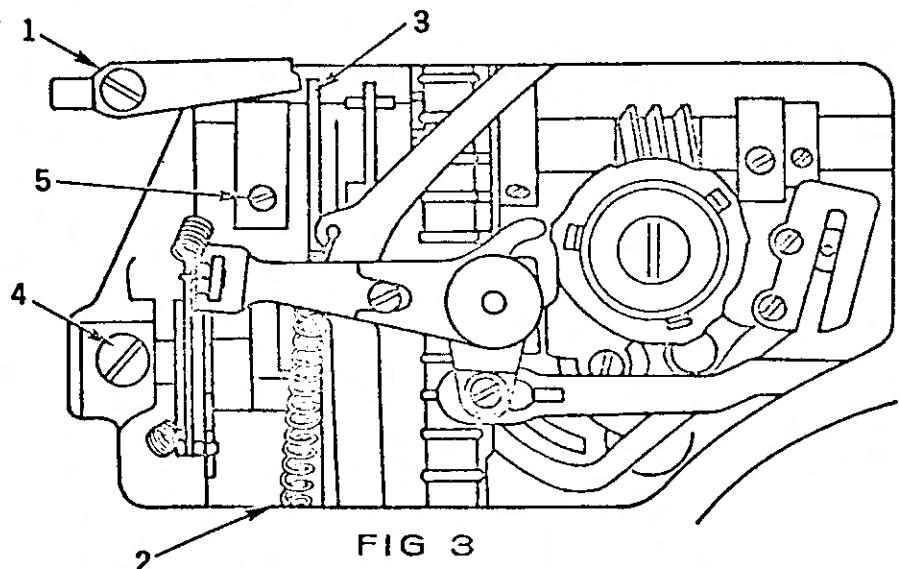

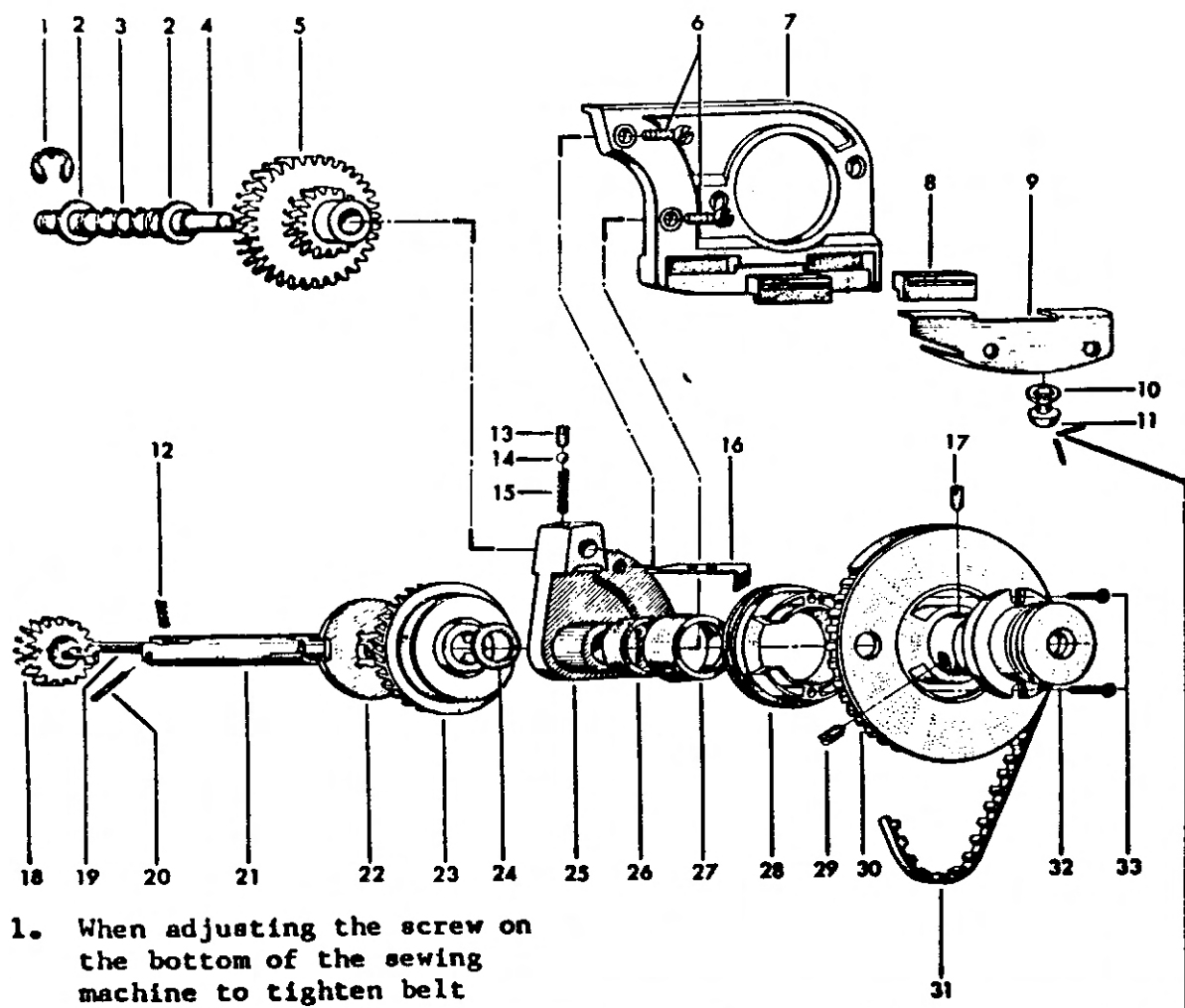

1. When adjusting the screw on the bottom of the sewing machine to tighten belt #40-11-660

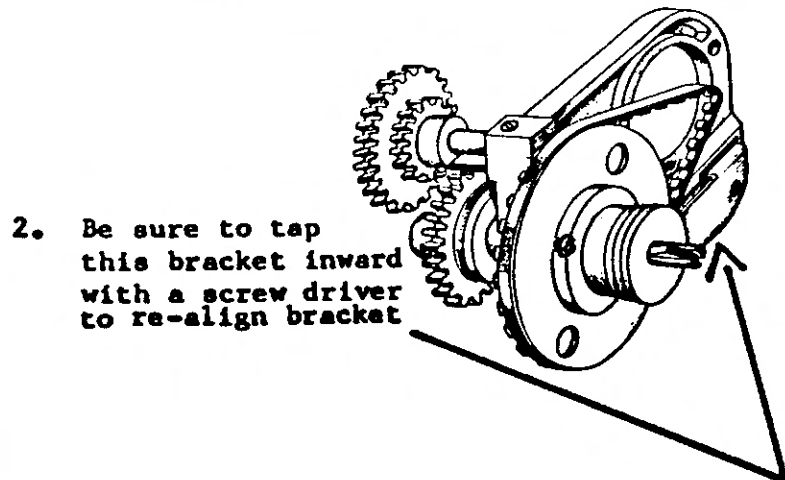

2. Be sure to tap this bracket inward with a screw driver to re-align bracket

## SOME OF THE MOST COMMON SEWING MACHINE TROUBLES

### MACHINE RUNNING ROUGHLY OR SLOW:

1. Drive belt may be too tight.
2. Gears over-meshed.
3. Worm gear improperly meshed.
4. Thread caught in various gears.
5. Reduction gear not turning freely.
6. Lint between rows of teeth on feed dog.

### MACHINE NOT FEEDING PROPERLY:

1. Feed dogs not set at right height.
2. Insufficient pressure on presser foot.
3. Feed not timed right.
4. Presser bar too high and not resting on material when in lowered position.
5. Drop feed lowered.

### NEEDLES BREAKING:

1. Improper needle being used.
2. Needle not inserted correctly.
3. Poor quality needle being used.
4. Operator pulling cloth.
5. Needle bar not centered.
6. Hook to needle setting incorrect.
7. Race cover too far back.

### UPPER THREAD BREAKS:

1. Needle not inserted correctly.
2. Machine not threaded properly.
3. Tension on the upper thread too tight.
4. Knots in thread.
5. Needle too small for thread.
6. Needle bent.
7. Needle plate broken or nicked and sharp.

### LOWER THREAD BREAKS:

1. Bobbin case not inserted correctly.
2. Lower thread tension too tight.
3. Bobbin case not threaded correctly.
4. Thread around shuttle post.
5. Bobbin wound too tight.

### LOWER THREAD DOES NOT COME UP:

1. Needle inserted incorrectly.
2. Needle bar height not right.
3. Race cover too tight.

### MACHINE SEWING POORLY:

1. Needle bent or blunted.
2. Needle inserted incorrectly.
3. Machine threaded incorrectly
4. Wrong size of needle used.
5. Thread too heavy for the needle.
6. Upper thread tension not set right.
7. Lower tension not set right.
8. Upper thread or needle not suited to the material.

STITCHING LOOSELY - WITH LOOPS AT THE UNDERSIDE OF THE MATERIAL

1. Machine not threaded correctly.
2. Presser foot not let down properly.
3. Upper thread tension too light.
4. Thread take-up spring bent or broken.
5. Thread take-up not traveling enough.

THREAD TENSION UNEVEN:

1. Poor quality thread is a likely cause.
2. Thread take-up spring releasing too soon.

WRINKLING OF MATERIAL:

1. Upper tension too tight.
2. Lower tension too tight.
3. Presser foot pressure too great.
4. Thread take-up spring not releasing.

STITCHES OF VARYING LENGTH:

1. Feed dog is clogged with lint.
2. Feed dogs too low.
3. Presser foot pressure too light.

MACHINE STITCHES WITH ZIGZAG WHEN SET ON STRAIGHT STITCH:

1. See step 31 on 33 point check

MACHINE SEWS IN REVERSE

1. Check stitch pattern setting to make sure that machine is on a pattern, not on the dot.
2. Check reverse button for sticking.
3. Check feed timing.

MACHINE SEWS WRONG PATTERN:

1. Check to see if cam is locked in place.
2. Check to see if cam follower is following right pattern.
3. Check to see if cam follower is following two patterns.

MOTOR DOES NOT RUN:

1. Check motor brushes
2. Check cord for short.