

SERVICE MANUAL

9940/20/10

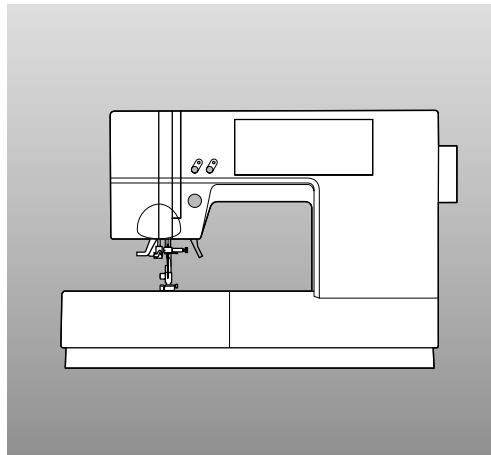

SINGER®

Table of contents

REMOVING THE EXTERIOR PARTS	3
A. Light Cover	3
B. Base	3
C. Top Cover (Flap)	4
D. Hinge Cover	4
E. Thread Tension Cover	4
F. Side Enclosure	5
G. Handle and Unit Cover	5
H. Needle Plate	6
I. Front Enclosure	7
J. Rear Enclosure	8
K. Front panel (from Front Enclosure)	8
REPLACING THE EXTERIOR PARTS	9
K. Front panel (to Front Enclosure)	9
J. Rear Enclosure	9
I. Front Enclosure	10
H. Needle Plate	10
G. Handle and Unit Cover	11
F. Side Enclosure	12
E. Thread Tension Cover	12
D. Hinge Cover	12
C. Top Cover (Flap)	13
B. Base	13
A. Light Cover	14
CHECK AND ADJUSTMENT	15
1. HEIGHT OF NEEDLE BAR	15
2. GAP BETWEEN NEEDLE AND HOOK	16
3. TIMING OF THE HOOK	17
4. HEIGHT OF THE FEED DOG	18
5. NEEDLE PLATE AND NEEDLE POSITION	19
6. TIMING OF THE UPPER AND LOWER SHAFT	20
7. ADJUSTING THE FORWARD REVERSE STITCH	21
8. BOBBIN WINDER	22
9. HEIGHT AND DIRECTION OF PRESSER FOOT	23
10. HEIGHT OF NEEDLE THREADER	24
11. ADJUSTMENTS FOR BUTTONHOLE LEVER POSITION	25
12. MOTOR BELT TENSION	26
13. TIMING BELT TENSION	26
14. BACKLASH OF HOOK GEAR	27
15. UPPER THREAD TENSION UNIT	28
16. ADJUSTING THE LOWER THREAD TENSION	28
17. FLATNESS OF THE BASE	28
LOCATING THE DEFECTED ELECTRICAL PART	29
1. To turn off the audible beep	29
2. The self-diagnostic program	29
3. Messages on LCD (9940/9920)	33
4. Electrical Parts Connection	34

SINGER® is a registered Trademark of The Singer Company Ltd.

REMOVING THE EXTERIOR PARTS

The exterior parts should be removed in sequence as followings.

CAUTION:

Always disconnect the main lead plug from electrical outlet when removing the exterior parts.

A. Light Cover

1. Loosen the light cover set screw (a).

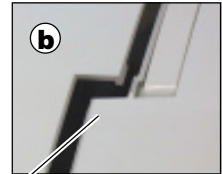
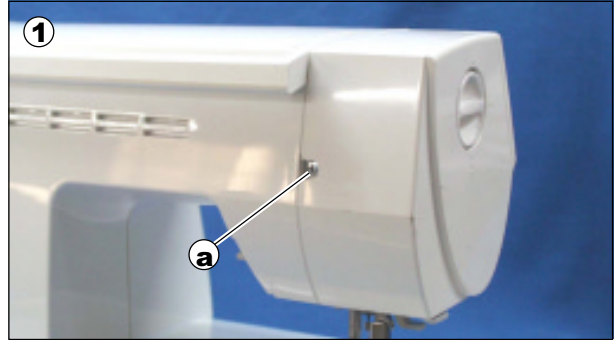

2. Pull light cover as shown so that the light cover hook (b) will come off.



B. Base

1. Remove the extension table.
2. Tilt the machine backward and remove the 3 base set screws (a, b, c). Remove the base.

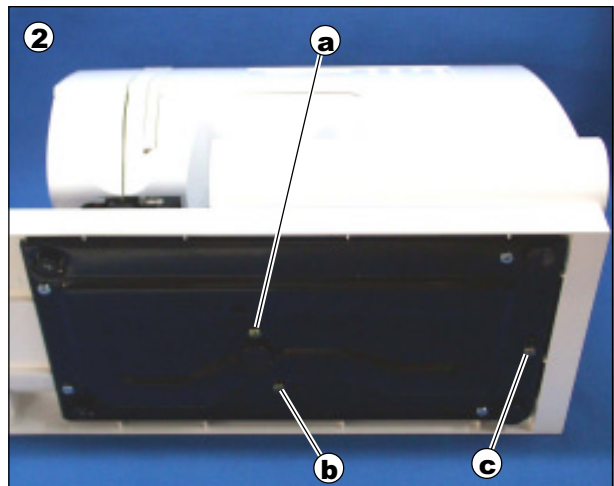

3. Carefully disconnect the connector with holding the lever (d).

This connector connects terminal box and power circuit board.

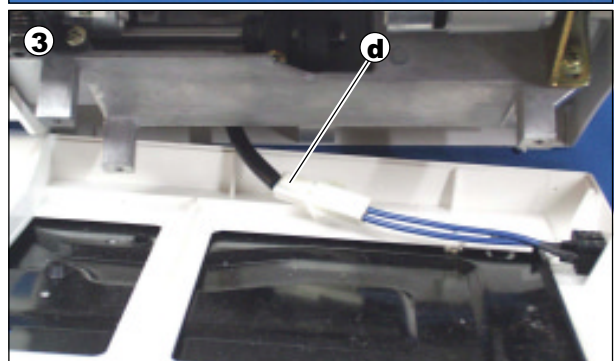

C. Top Cover (Flap)

1. Open the top cover.
2. Push the right side of top cover backward and remove the hinge (a).

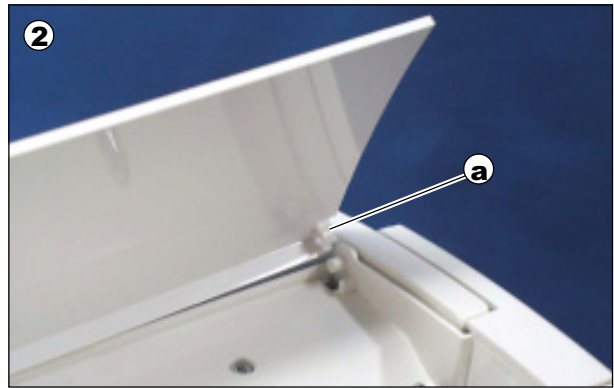

3. Slide the top cover to the right and remove the hinge (b).

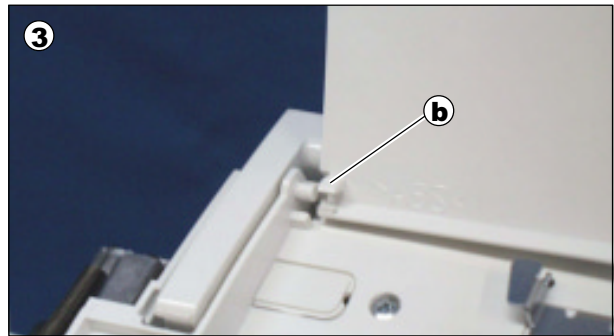

D. Hinge Cover

1. Insert the tip of screw driver and pull up the front side of hinge cover.



E. Thread Tension Cover

1. Remove the screw (a).
2. Push the Thread tension cover backward ; 2 hooks (b, c) will come off.
3. Pull up the cover.

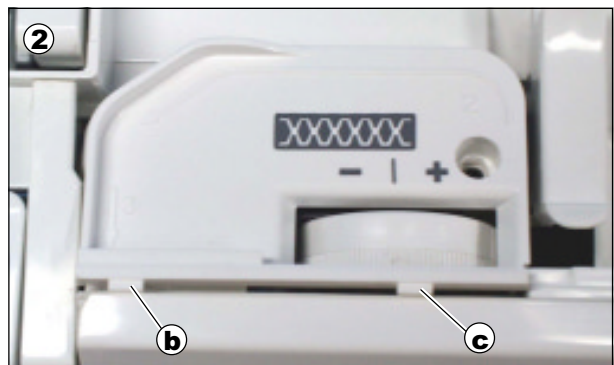
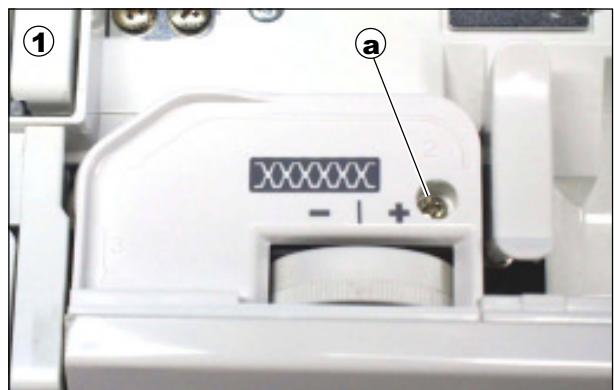

F. Side Enclosure

1. Remove the screw (a).



2. Push the side enclosure slightly backward to come off the 2 hooks (b, c).

3. Pull the side enclosure to the right and remove it.

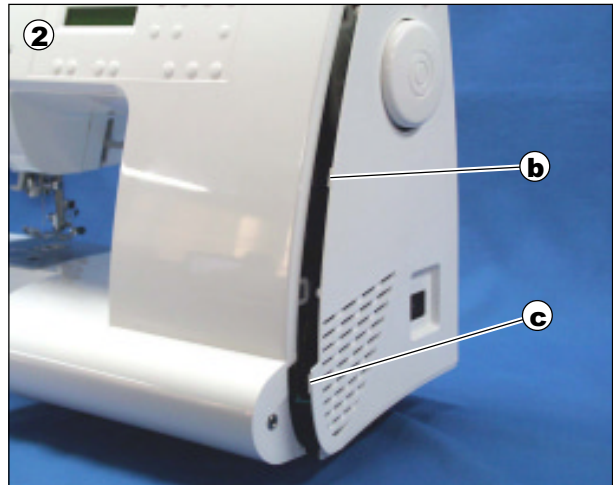

G. Handle and Unit Cover

1. Remove the unit cover set screws (a, b) and handle set screws (c, d).

2. Stand up the handle.

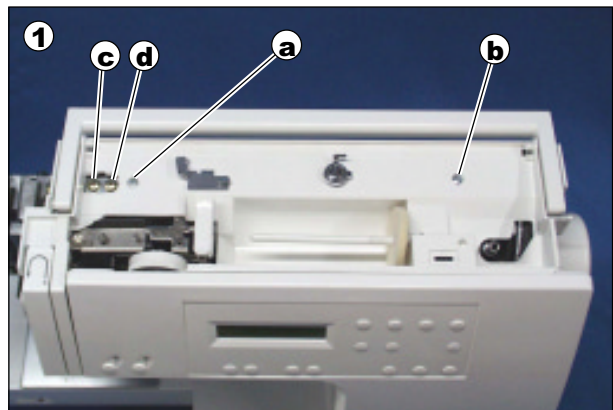

3. Push the right side of unit cover backward so that the hook of unit cover will come off and pull up.



4. Next, push the left side of unit cover backward and pull up it to come off from the thread guide cover.



5. Slide the handle and unit cover to the left and remove them.
6. Carefully disconnect the connector which connects to the contrast control board.

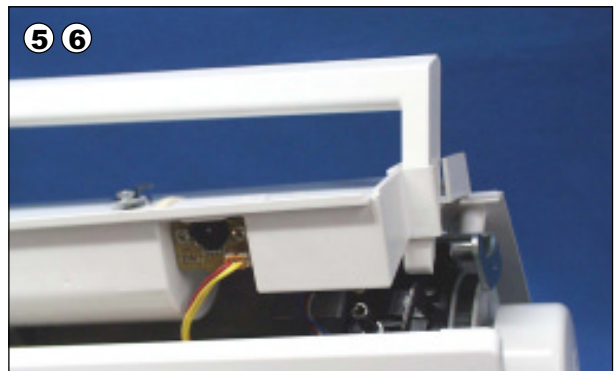

H. Needle Plate

1. Remove the presser foot.
2. Remove the 2 screws (a, b) holding the needle plate.

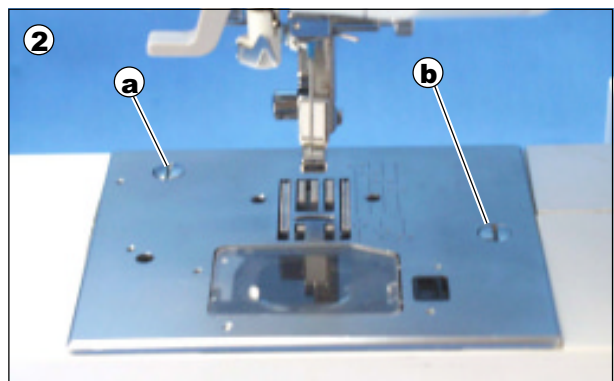

3. Lift up the right side of needle plate and remove it.

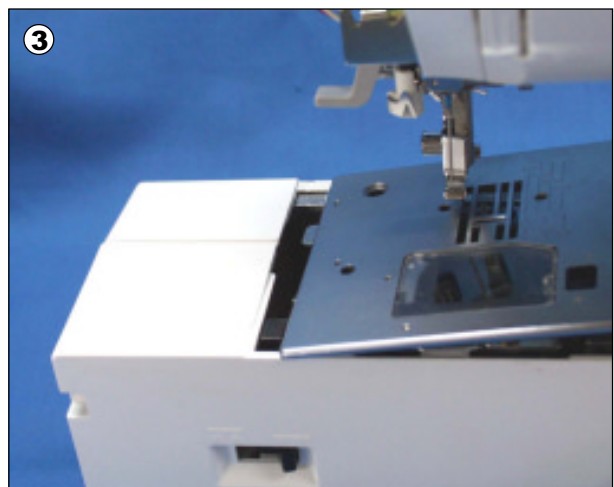

I. Front Enclosure

1. Loosen the screw (a).

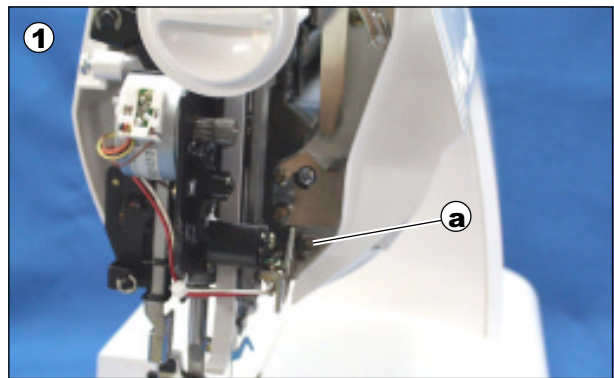

2. Push the left side of rear enclosure (b) and pull the front enclosure (hook-c will come off).

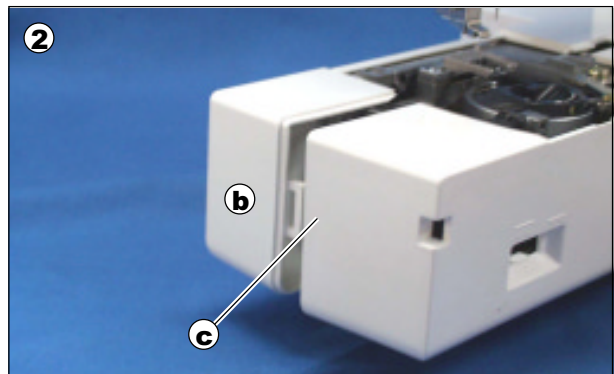

3. Pull up the front enclosure and come off the hook-d.
4. Pull the enclosure to the left and come off the hook-e.

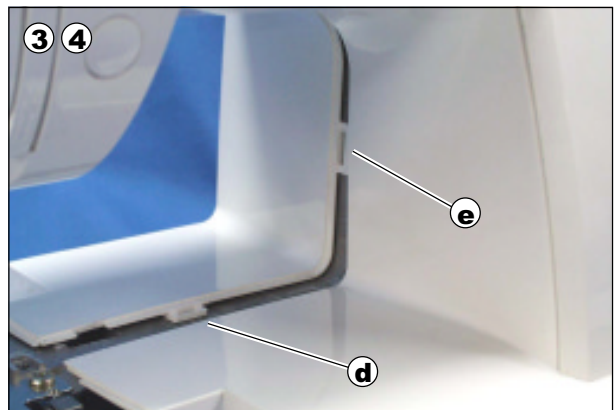

5. Push the rear enclosure to the left and come off the hook-f.



6. Disconnect the 2 connectors (g, h) from the machine and remove the front enclosure.

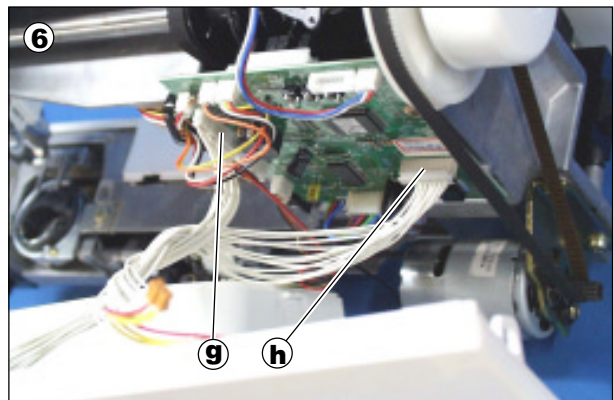

J. Rear Enclosure

1. Lower the presser foot lifter.
2. Remove the 3 screws (a, b, c).
(screw-c is longer than others.)
3. Pull the rear enclosure backward and remove it.

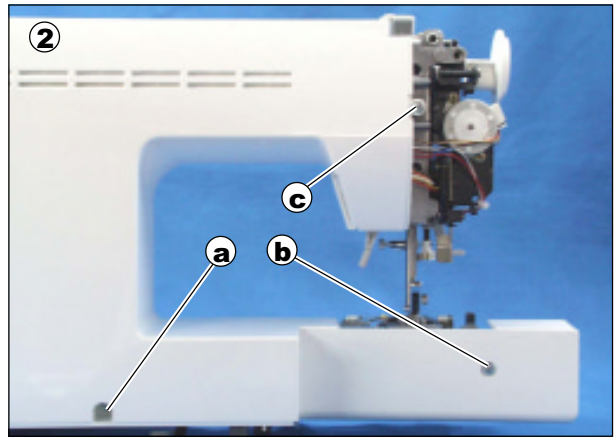

K. Front panel (from Front Enclosure)

1. Disconnect the 2 connectors from the front panel (a: Reverse switch board) (b: Controller jack assy.)

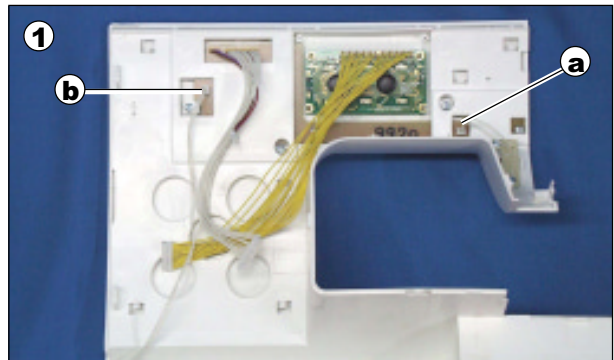

TYPE A (Secured by 4 screws)

2. Remove the 4 screws (c, d, e, f).
3. Push the lower hook (g) downward and push the upper hooks (h, i) upward to come off.

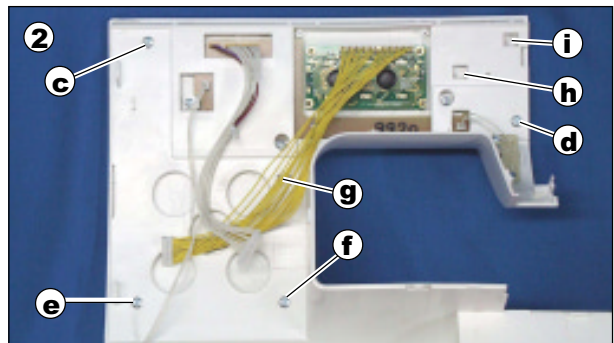

TYPE B (Locked by hooks)

2. Push the lower 3 hooks (j, k, l) downward to come off them.
3. Push the upper 3 hooks upward to come off them.

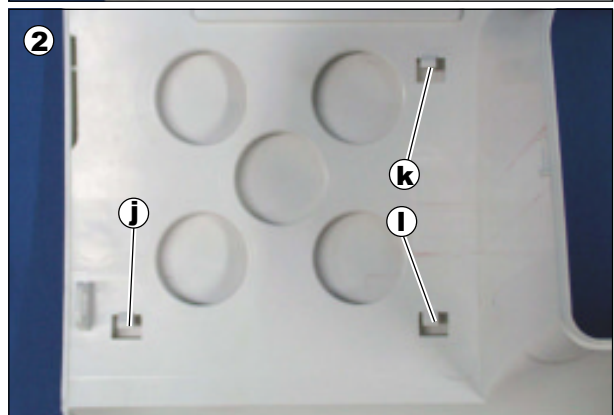

4. Pull up the front panel backward and remove it. (3 hooks on front panel will come off)

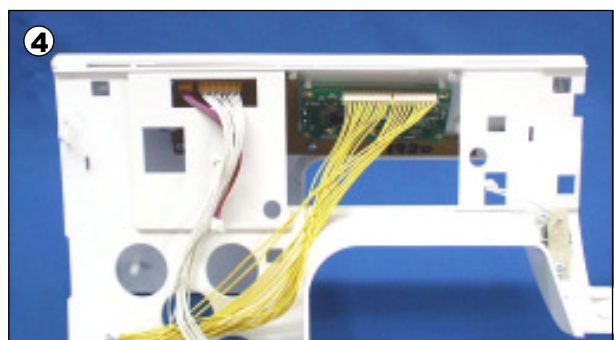

REPLACING THE EXTERIOR PARTS

The exterior parts should be replaced in reverse sequence when removing. (K. to A.)

K. Front panel (to Front Enclosure)

1. Pass the cords through the openings of front enclosure.
2. Ride the 3 hooks of front panel on the front enclosure.

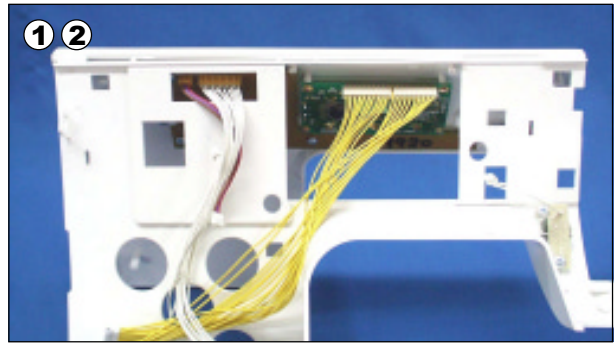

TYPE A (Secured by 4 screws)

3. Push front enclosure around the hook and fit them in place.
Retighten the 4 screws.

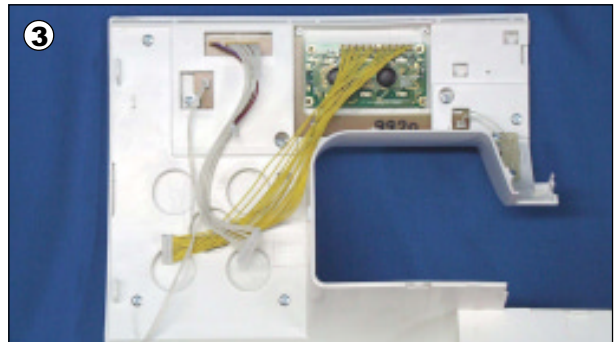

TYPE B (Locked by hooks)

3. Push front enclosure around the hook and fit them in place.



4. Connect the 2 connectors (a: Reverse switch board)
(b: Controller jack assy.)

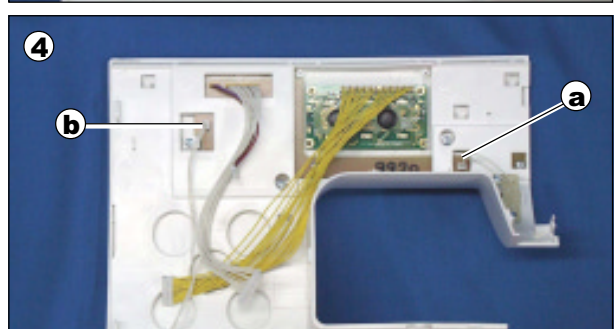

J. Rear Enclosure

1. Lower the presser foot lifter.
2. Replace the rear enclosure.
3. Retighten the 3 screws (a, b, c).
(Screw-c is longer than others and replace loosely.)

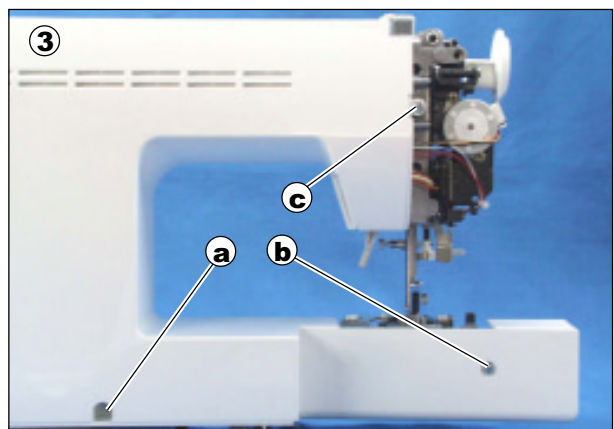

I. Front Enclosure

1. Connect the 2 connectors (g, h) to the machine.

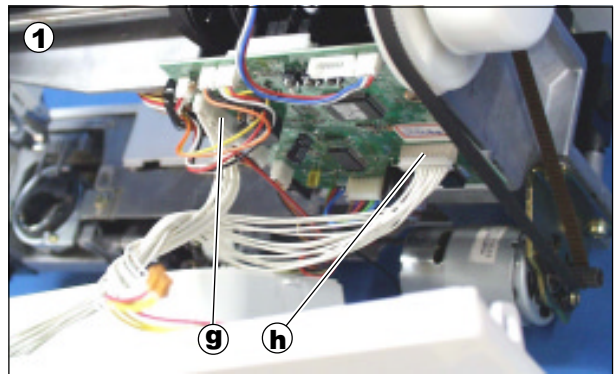

2. Replace the front enclosure so that the 4 hooks will fit in place.



3. Push lower end of front enclosure arm backward and retighten the screw (a).

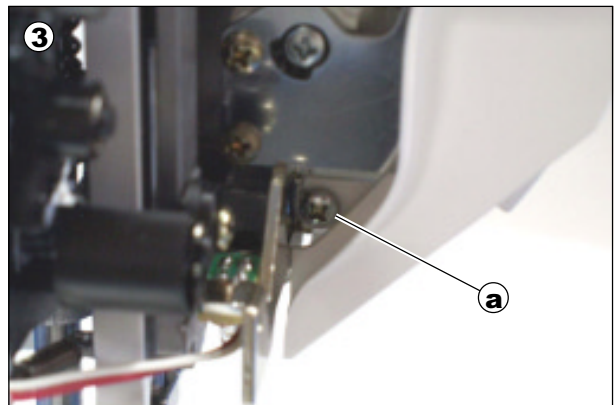

H. Needle Plate

1. Insert the hook (c) of needle plate to the machine.

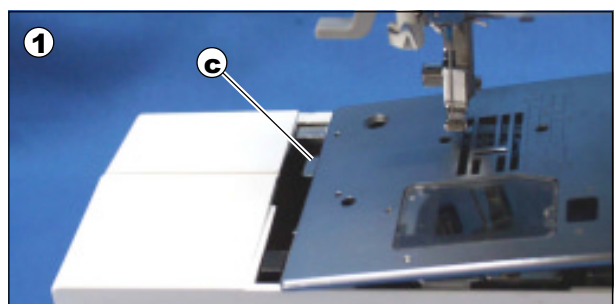

2. Retighten the screws (a, b).

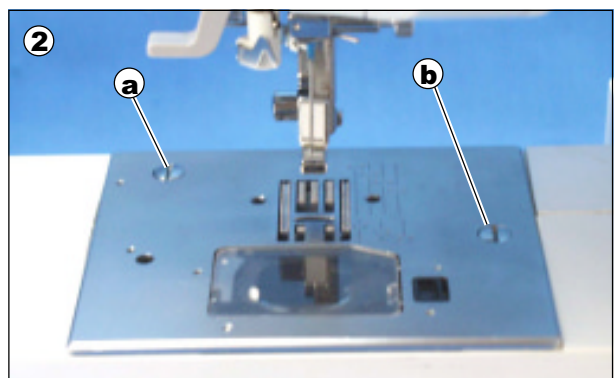

G. Handle and Unit Cover

1. Set the handle to the unit cover and insert the handle hinge pin into the left side hole of handle from left side.

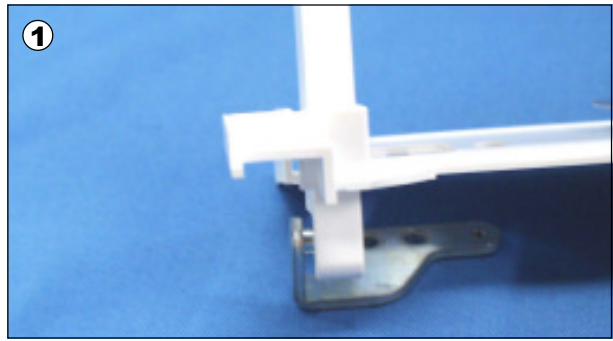

2. Place the handle and unit cover onto the top of machine.



3. Connect the connector to the contrast control board.



4. Insert the hinge pin on the machine into the right side hole of handle.

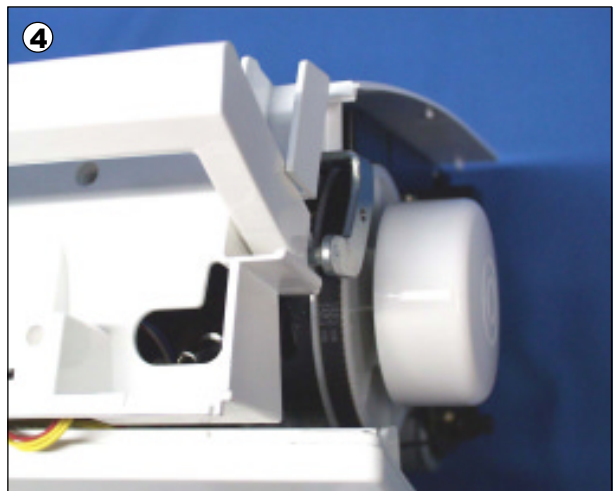

5. Replace the unit cover so that the each hook fit into place.

6. Retighten the handle set screws (c, d) and unit cover set screws (a, b).

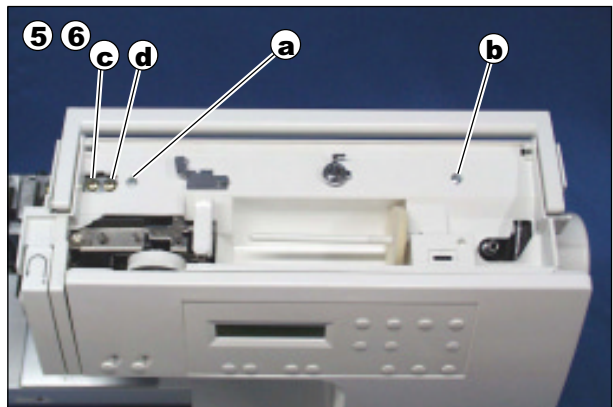

F. Side Enclosure

1. Replace the side enclosure so that the each hook fit into place.
2. Retighten the screw (a).

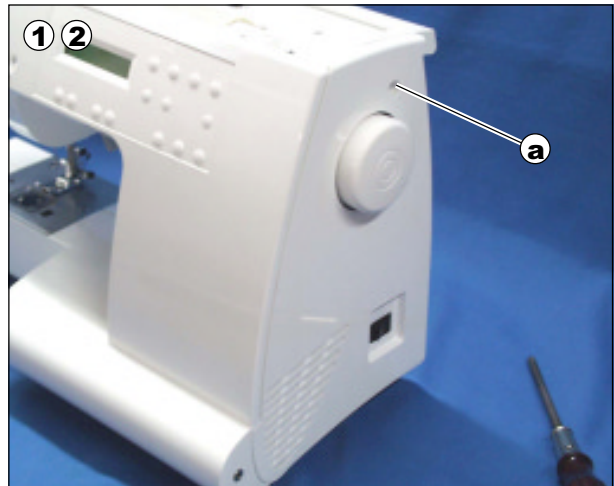

E. Thread Tension Cover

1. Replace the thread tension cover so that the each hook fit into place.
2. Retighten the screw (e).

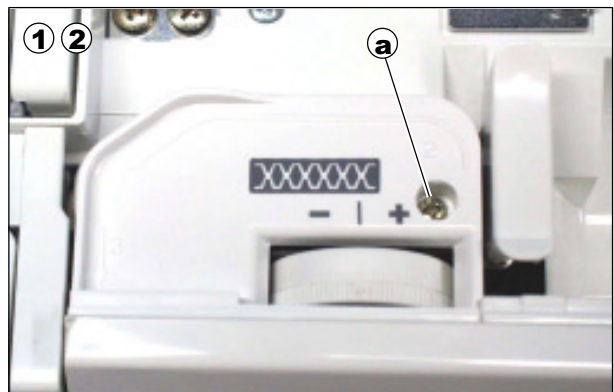

D. Hinge Cover

1. Insert the rear hook into the machine and push the hinge cover.



C. Top Cover (Flap)

1. Slide the top cover to the left so that the hook (b) will fit onto the pin of unit cover.

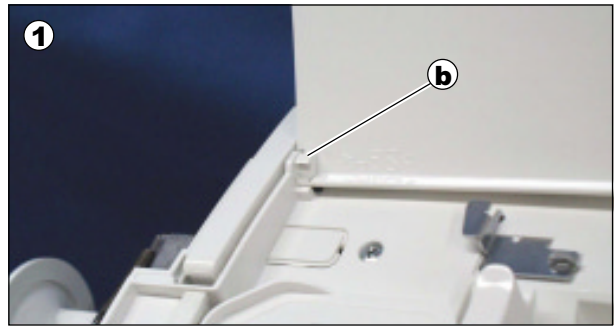

2. Pull the right side of top cover and snap on the hook (a) onto the pin of unit cover.

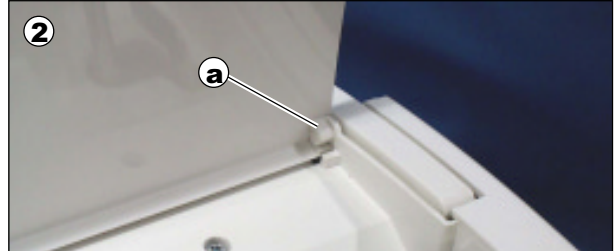

B. Base

1. Tilt the machine backward.
2. Connect the connector so that the hook (d) will fit into place.
3. Replace the base and retighten the 3 screws.

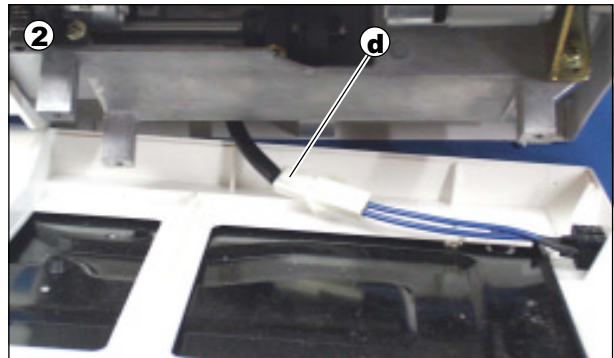

A. Light Cover

1. Loosen the light cover set screw (a).

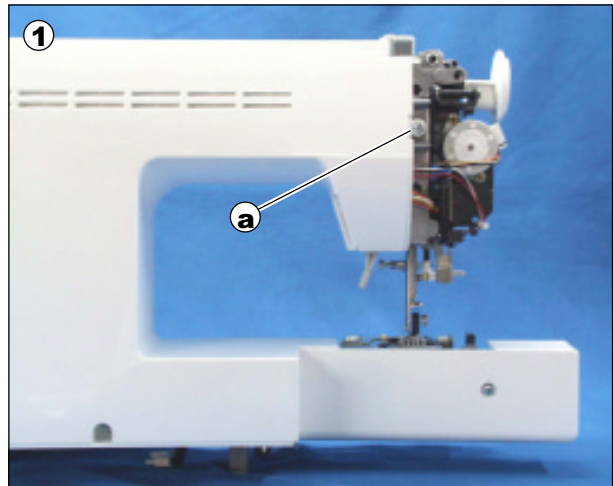

2. Replace the light cover so so that the hook (b) will fit into place.



3. Retighten the screw (a).



CHECK AND ADJUSTMENT

1. HEIGHT OF NEEDLE BAR

Height of needle bar could be the cause for stitches to skip. Check as the following procedures.

1. Set the pattern to [Utility stitch No.1] which is straight stitch on center needle position.
2. Raise the needle bar to its highest point by turning the handwheel toward you. Remove the presser foot. Remove the needle plate. Lift up the bobbin holder and remove it.
3. Turn the handwheel toward you until the needle comes to its lowest point.
4. Then, the spacing between the surface of hook race and the top edge of needle eye must be 4.9 ± 0.1 mm).

If this spacing is not correct, adjust as follows.

5. Remove the light cover.
 6. Remove the 2 screws (a, b) and remove the take up lever cover and bracket (c) by sliding it upward.
- (Bottom hook of cover will come off)

7. Raise the needle bar 4.9mm from its lowest point by turning the handwheel.
Loosen the screw (d) on the needle bar holder. (2 mm hex. wrench)
Adjust the needle bar so that the top edge of needle eye is aligned with the surface of hook race.
Retighten the screw (d) and check the height again.

CAUTION: Do not change the needle bar direction at this adjustment. The long groove of needle must be facing frontwards.

8. Replace the take up lever cover and screws.

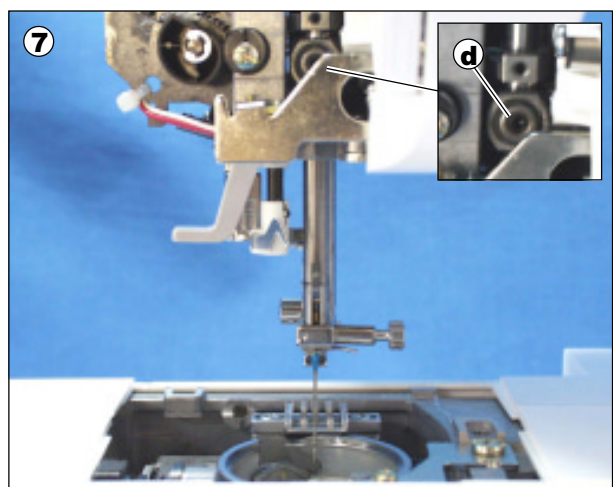
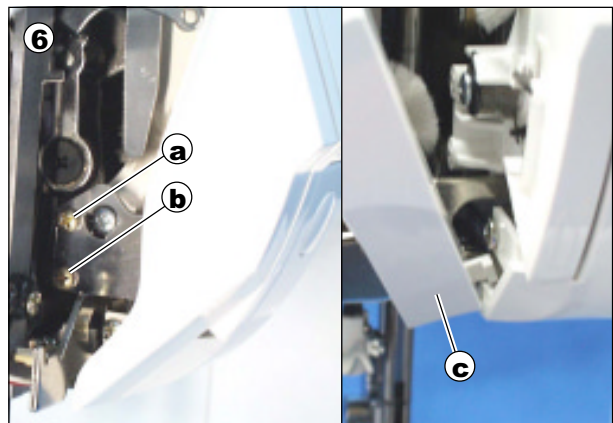
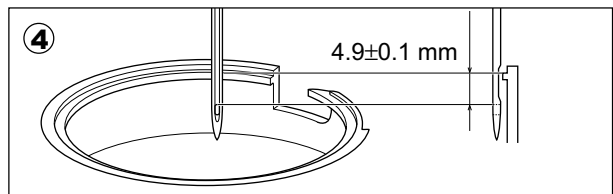
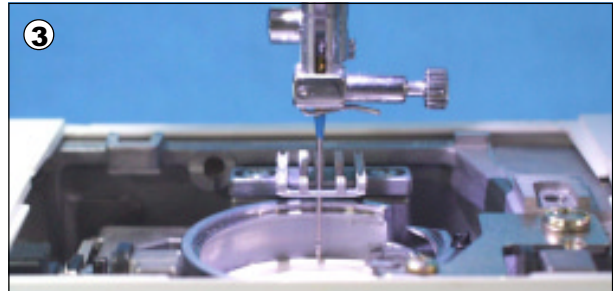
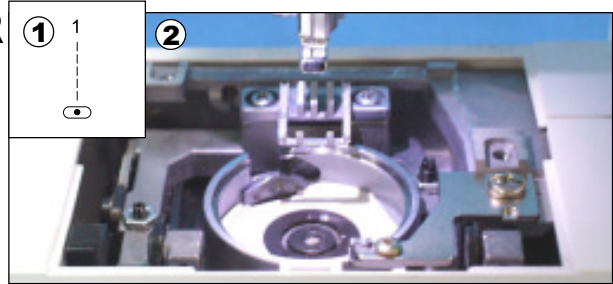

2. GAP BETWEEN NEEDLE AND HOOK

If the needle hits against the hook, it may be the cause of needle and thread breakages. If the gap between needle and hook is too big, it will cause to skip stitches. Check and adjust as follows:

Prior to make this adjustment, check that the needle is not bent and the needle is inserted correctly.

1. Remove the needle plate and bobbin holder.
2. Set the pattern at [Utility No. 2]. (Straight stitch on left needle position.)
3. Turn the handwheel toward you until the needle will cross over the hook.
4. Then, check the gap between needle and hook is about 0.10 to 0.20 mm.

If the needle is hitting against the hook or if the gap is too much, adjust as follows:

5. Remove the light cover.
6. Adjust the gap by turning the adjusting screw (a) with 2 mm hex. wrench.
 - If the gap is too big, turn the screw to the left with viewing from frontward.
 - If the needle is hitting the hook, turn the screw to the right with viewing from frontward.
7. Replace the bobbin holder and needle plate and light cover.

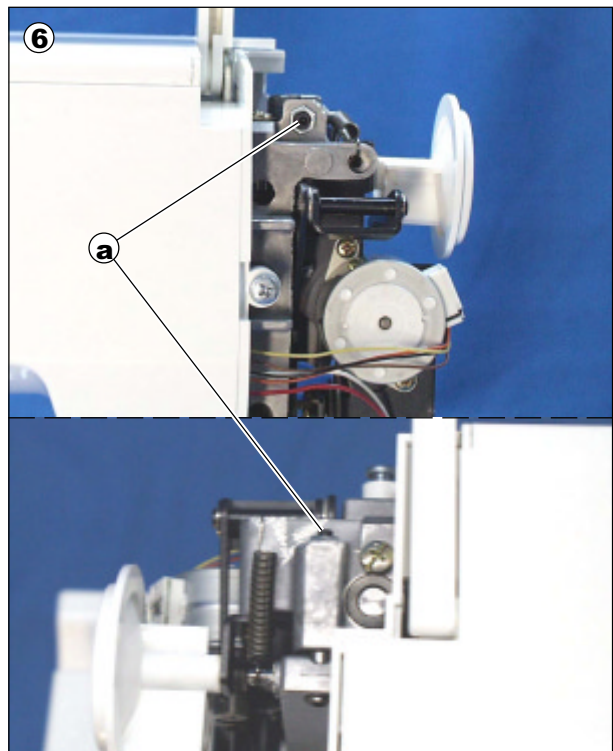
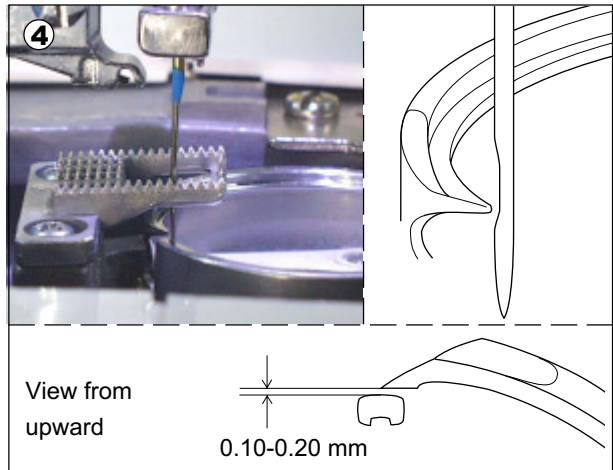
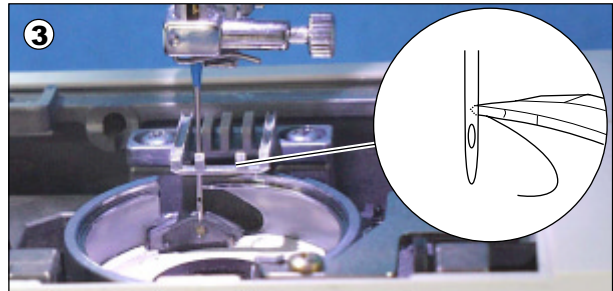
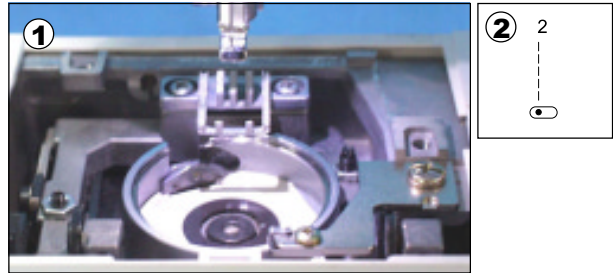

3. TIMING OF THE HOOK

Prior to making this adjustment, be sure that the needle bar is set at the correct height. (Sec. 1)

Check the timing of hook as follows:

1. Remove the needle plate and bobbin holder.
2. Set the pattern at [Utility No. 2]. (Straight stitch on left needle position.)
3. Turn the handwheel toward you until the needle is at its lowest point.
4. Then, turn the handwheel slowly to turn the hook counter-clockwise until the tip of hook is aligned with the right side of needle.
At this time, the gap between the tip of hook and the top edge of needle eye should be $(1.3\pm 0.2 \text{ mm})$.

If the gap is too small or too large, adjust as follows:

5. Remove the front enclosure.
6. Loosen the two 2 screws (a) on the lower shaft gear with a 2.5 mm hex. wrench.
7. Turn the hook race by hand so that the tip of hook will align with the right side of needle.
8. In this position, hold the hook race with your left hand and turn the handwheel toward you to obtain the correct gap (1.3 mm).
9. Tighten the screws and check the timing again.
10. Replace the front enclosure.

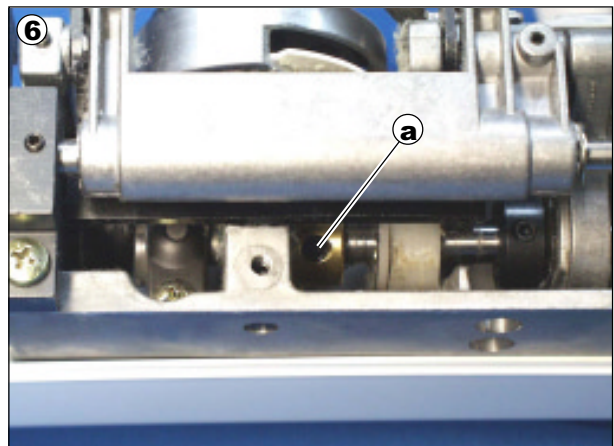
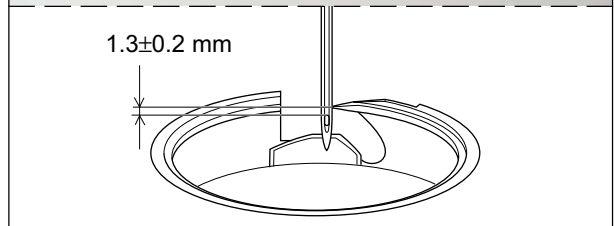
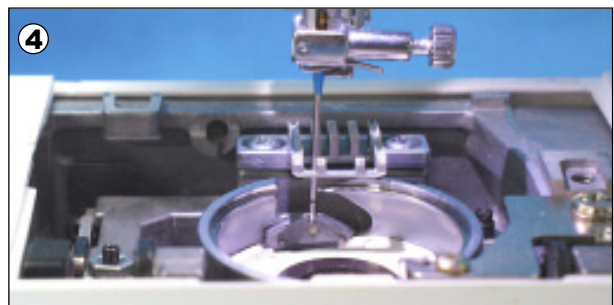
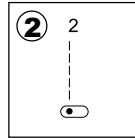
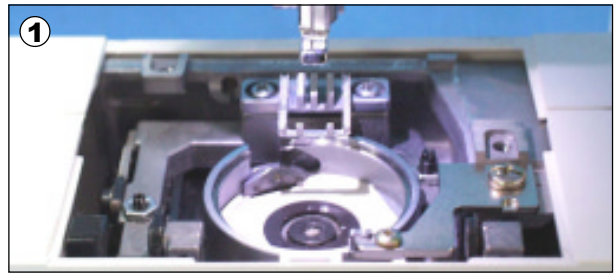

4. HEIGHT OF THE FEED DOG

If the feed dog does not come up over the needle plate enough, it will result in insufficient and/or uneven feed of fabrics.

1. The feed dog should come up over the needle plate (1.0-1.1 mm) when its highest position.

If it does not come up enough, adjust as follows:

2. Remove the needle plate.

3. Lower the presser foot lifter. Turn the handwheel until the feed dog comes to its highest position.

- If the feed dog is too low;
Turn the adjusting screw (a) (1.5mm hex. wrench) clockwise until correct height is obtained.
Turn the screw (b) clockwise until the cam follower (c) touches the feed rocking cam (Right)(d).
(To check it, remove the front enclosure and see frontward.)

- If the feed dog is too high;
Turn the screws (a) and (b) counterclockwise in a few turns.
Push the left side of feed base strongly (e) (feed dog will come down)
Check that the feed dog came lower than the correct height. If it is not so, turn the screws counterclockwise again and lower the feed base.
After the feed dog is lower than the correct height, adjust the feed dog height same as "If the feed dog is too low".

4. Check that the cam followers (c) , (e) have to be even height and they have no opening to each cam (d), (f).

5. Re-check the height and motion of feed dog by turning the handwheel.

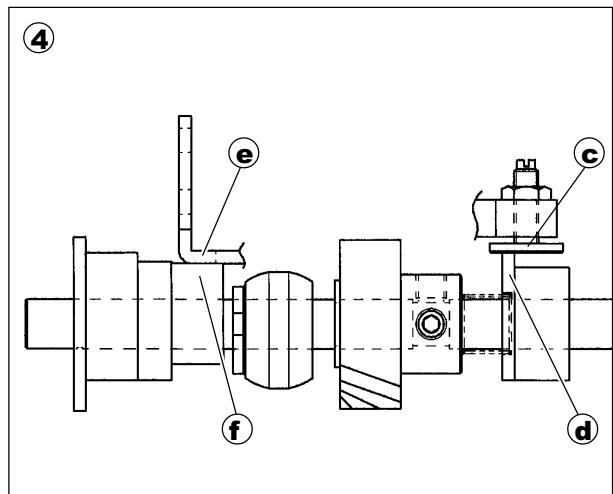
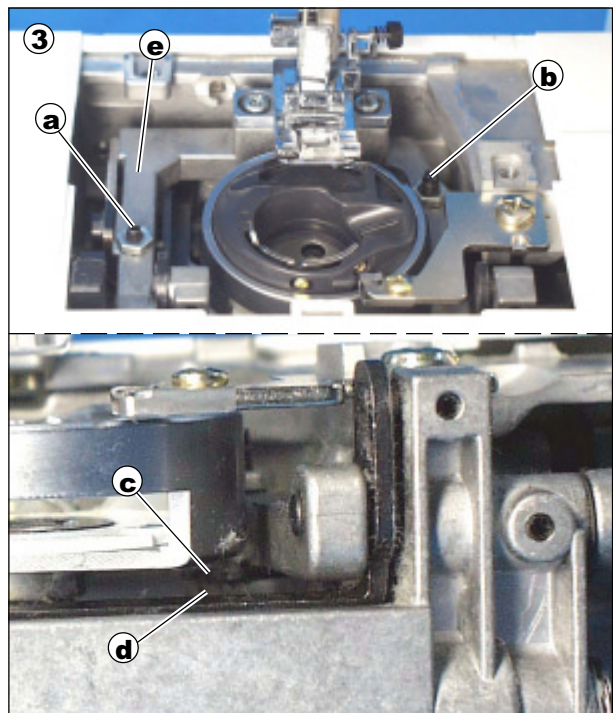
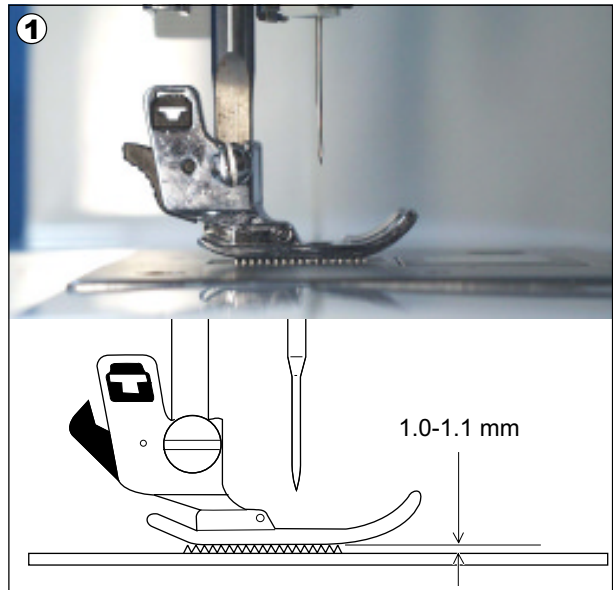

5. NEEDLE PLATE AND NEEDLE POSITION

1. When the straight stitches is set at center needle position (Utility No.1), the needle should fall into the center of needle plate hole (the distance needle and edge of hole at each side).

If it is not so, adjust as follows:

2. Set the pattern at [Utility No.1].

3. Remove the presser foot and the light cover.

4. Loosen the center screw (a).

5. Turn the adjusting screw (b) left or right until the needle falls center position into the hole.

- When you turn the screw to the right, needle will move to the left.
- When you turn the screw to the left, needle will move to the right.

6. Retighten the screw (a) and re-check the position of needle.

7. When you have adjusted the this position, check the timing of the hook again. (Sec. 3)

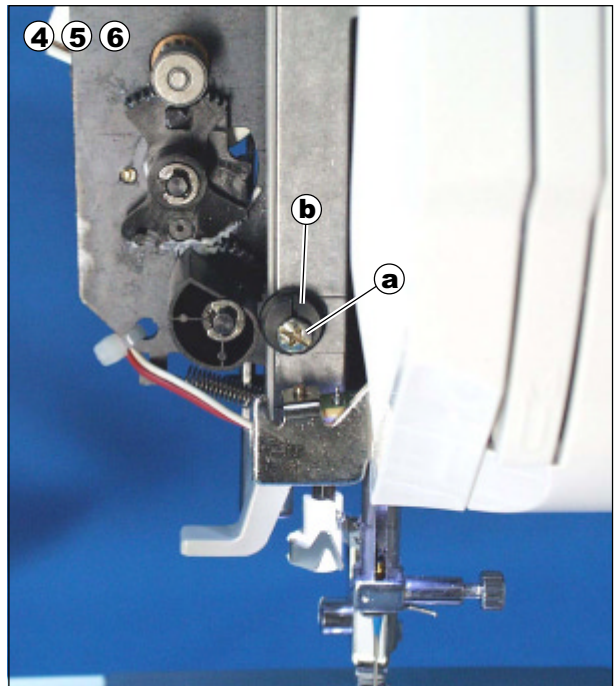
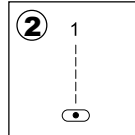
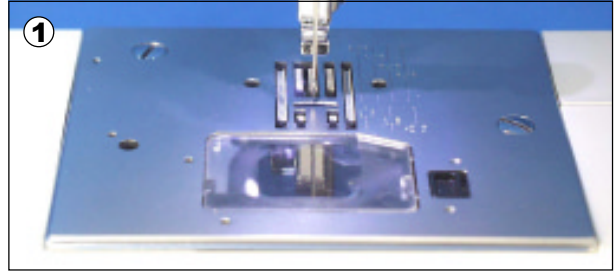

6. TIMING OF THE UPPER AND LOWER SHAFT

The upper and lower shaft must be positioned correctly as follows.

1. Remove the front enclosure.
2. Turn the handwheel toward you until the needle is its lowest point. At this time, the mark (a - very small molded line on edge) on the lower shaft timing pulley must be facing toward you.

If it is not so, adjust as follows:

3. Loosen the screw (b) tightening the tension pulley bracket.
4. Slip out the timing belt from lower shaft timing pulley.
5. Turn the lower shaft timing pulley so that the mark faces toward you.
6. Hook the timing belt on the pulley.
7. Push the tension pulley bracket so that the edge of bracket should be 0-1 mm higher than the casting.
8. Retighten the screw (b)
9. Check the timing again and replace the front enclosure.
10. When you have adjusted it, check the timing of the hook again. (Sec. 3)

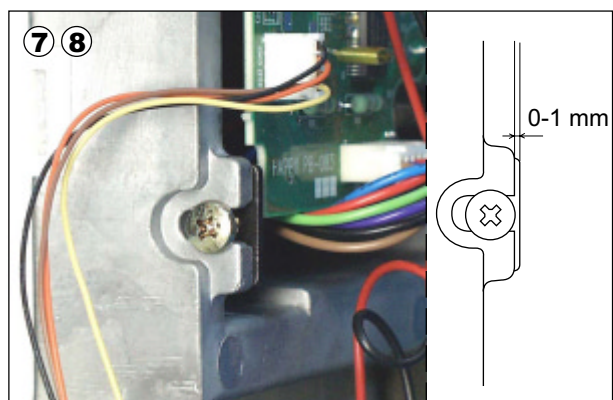
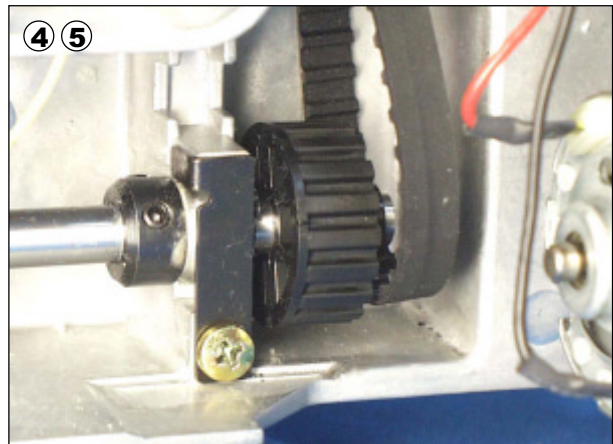
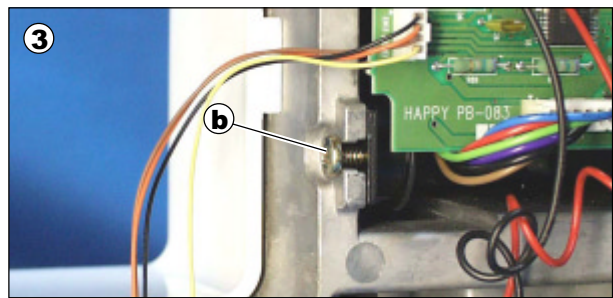
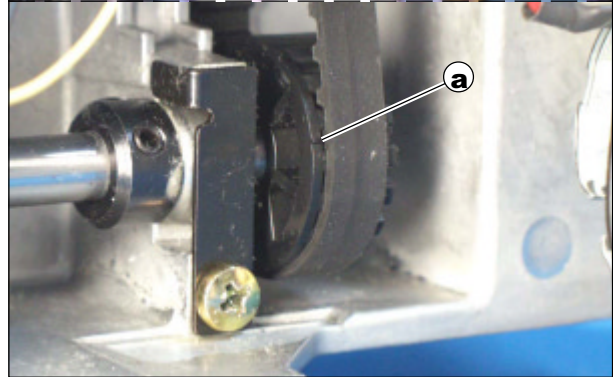
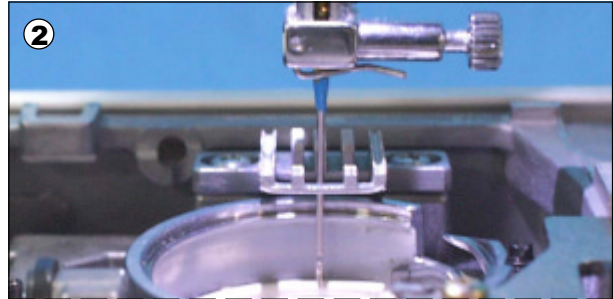

7. ADJUSTING THE FORWARD REVERSE STITCH

When stretch stitch sewing, the lengths of the forward and reverse stitches should be the same.

Check and adjust as follows.

- We recommend checking "Height of the Feed-dog (Sec. 4)" before you make this adjustment.

1. Turn on the power switch with pressing the buttons as shown. LCD will indicate the message "Feed Adjust".
2. Attach the general purpose foot and set a piece of paper under the foot.
3. Start the machine and open holes of test pattern. The holes (a) and (b) should be same position.

If they are not so, adjust as follows.

4. Remove the base.
5. Loosen the lock screw (c) (2.5 mm hex. wrench).
6. The forward-reverse stitch length is adjusted by turning the screw (d). (4mm hex. wrench)
 - If the reverse stitch is finer than the forward stitch, turn the screw to the left.
 - If the reverse stitch is coarser than the forward stitch, turn the screw to the right.
7. When correct height is obtained, retighten the lock screw (c) and replace the base.

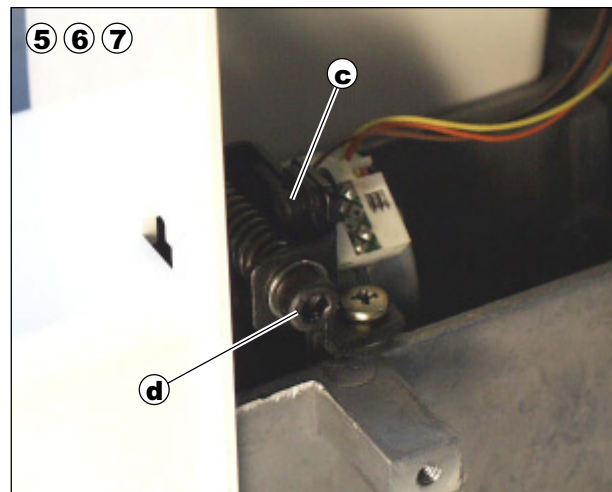
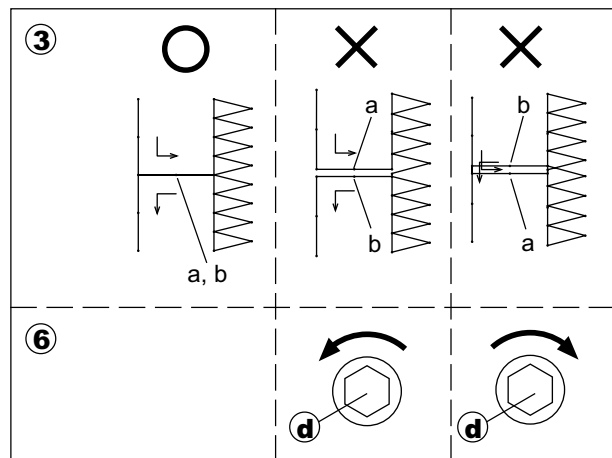
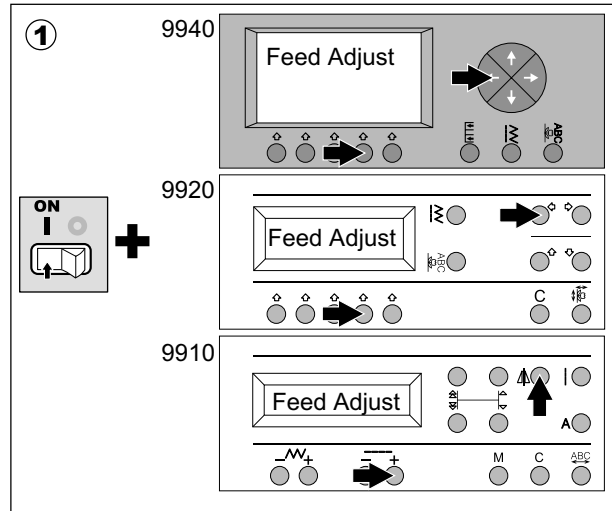

8. BOBBIN WINDER

If bobbin winds unevenly, adjust as follows:

1. If bobbin winds as shown, turn the adjusting screw (a) to the left.

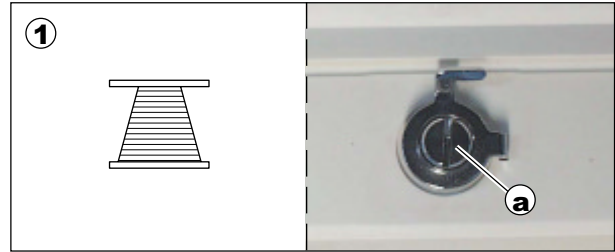

2. If bobbin winds as shown, turn the adjusting screw (a) to the right.



3. If the bobbin thread is wound too little or too much, loosen the screw (b) on bobbin winder stop (c) and adjust as follows.

4. If the bobbin thread is wound too much, slide the bobbin winder stop (c) to the left.

5. If the bobbin thread is wound too little, slide the bobbin winder stop (c) to the right.

6. Retighten the screw (b).

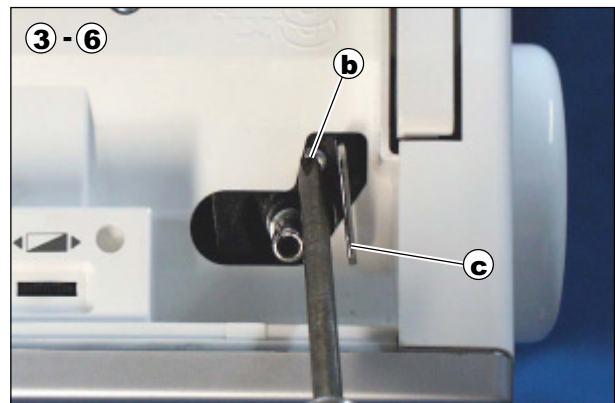

9. HEIGHT AND DIRECTION OF PRESSER FOOT

1. The height of the presser foot from the needle plate should be 6.5 mm when it is lifted up.
The presser foot should be facing forward (the edge of foot is parallel with the feed dog slot on needle plate).

If adjustment is needed, follow these procedures:

2. Remove the light cover.

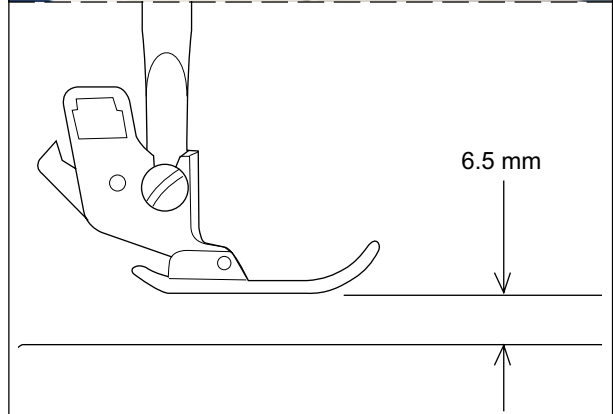
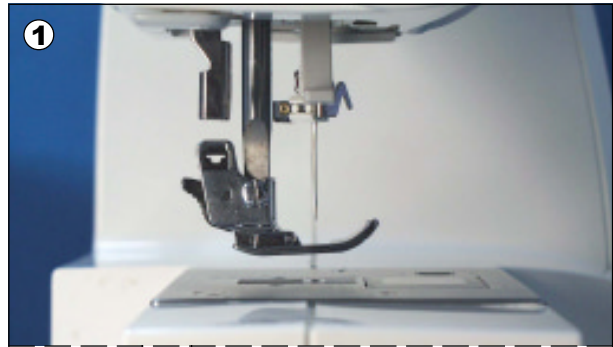

3. Loosen the screw (a) located behind of the machine.
4. Adjust the height and direction of presser foot.
5. Retighten the screw (a).
6. Check if the presser foot lifter has a slight play in down position.

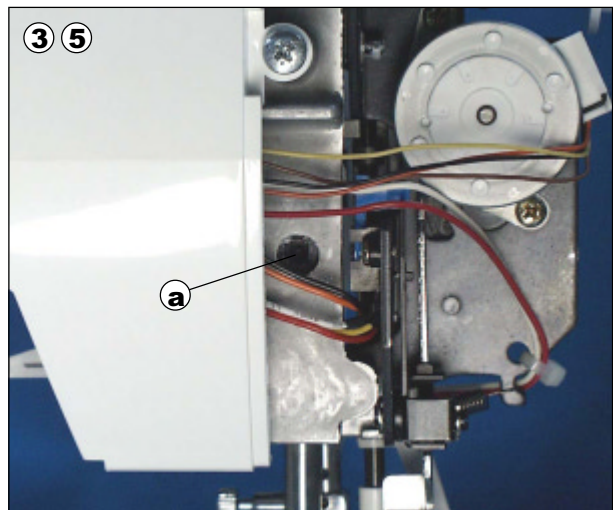

10. HEIGHT OF NEEDLE THREADER

If the height of needle threader is not correct, the hook on threader will not enter the needle eye. Adjust as follows:

1. Remove the light cover.
2. Remove the 2 screws (a, b) and remove the take up lever cover and bracket (c) by sliding it upward.
(Bottom hook of cover will come off)
3. Set the pattern at [Utility, No.2] (straight stitch on left needle position).
4. Raise the needle to its highest point by turning the handwheel.
5. Loosen the screw (d) on the needle threader bar stopper (e) with a 1.5 mm hex. wrench.
6. Adjust the height of stopper (e) so that the hook enter the needle eye.
7. Tighten the screw (d) and check the height of needle threader again.

CAUTION:

Be careful with direction of stopper when tighten the screw.

If direction of stopper NOT right, machine makes noise and/or threader does NOT work smoothly.
The correct direction is that the screw (d) is facing forward.

8. Replace the take up lever cover and screws.
 9. Replace the light cover.
- A. If the hook has bent, change the threader hook assembly. To remove the hook assembly, pull it downward.

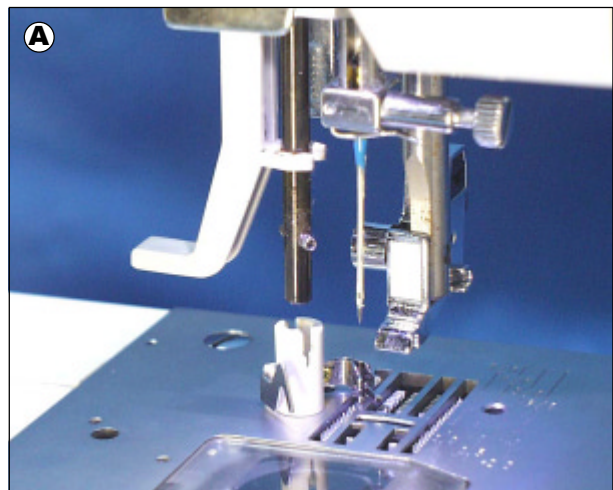
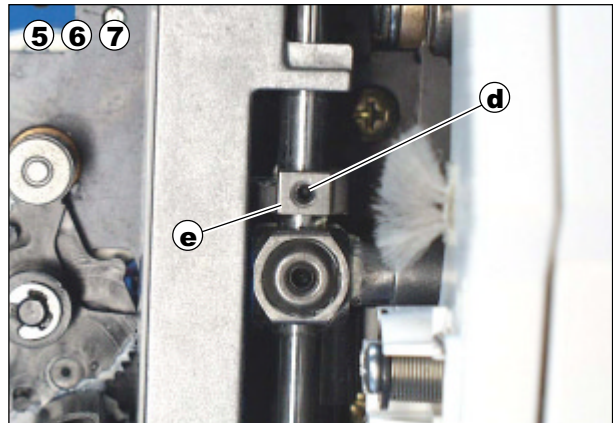
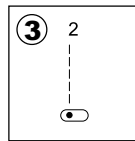
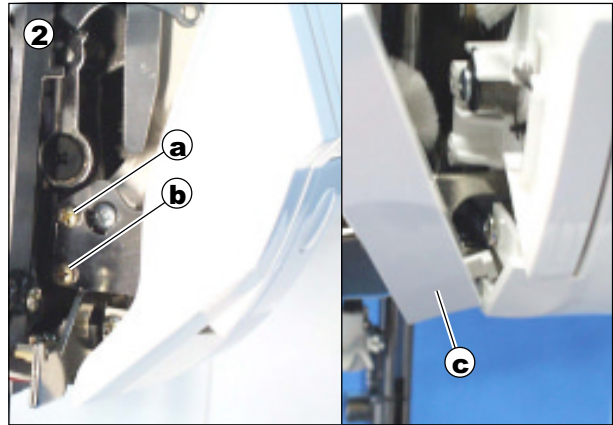

11. ADJUSTMENTS FOR BUTTONHOLE LEVER POSITION

1. If the machine dose not sew even with the buttonhole lever all the way down, it means that the buttonhole lever is not positioned properly. Also, if the buttonhole lever is not positioned properly, the machine will sew buttonhole as shown or incorrectly.
2. Turn on the power switch with pressing the buttons as shown. The self-diagnostic program will run.
3. Attach the buttonhole foot.
4. Lower the presser foot and the buttonhole lever.

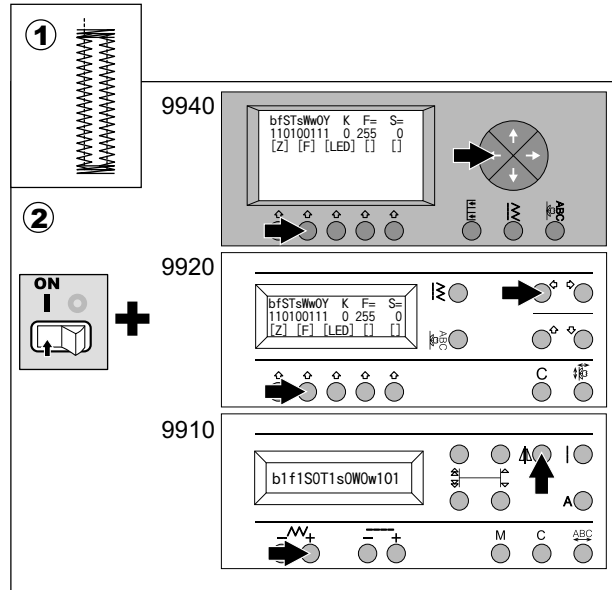

5. Push the presser foot frame backward about 1cm while lifting the presser foot lever slightly. Then slowly move the frame forward. Lower the lever when self-diagnostic program "b" changes to "0" from "1".

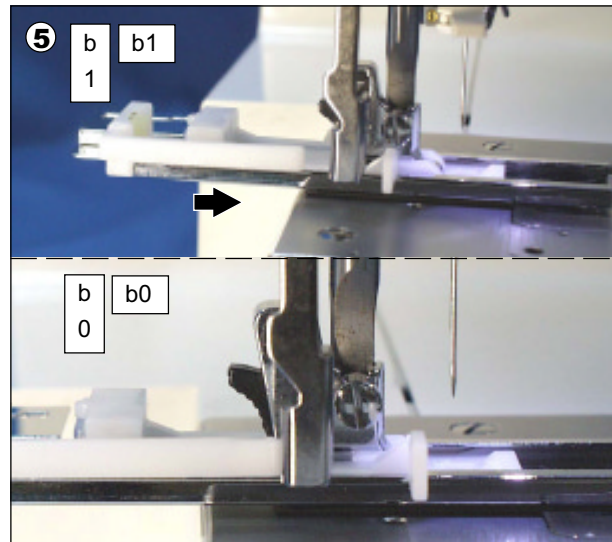

6. At this time, the presser foot frame should be about 1mm backward from the extreme end.

If it is not in correct position, adjust as follows:

7. Push the presser foot frame 1mm backward from the extreme end, and lower the presser foot.
8. Remove the light cover.
9. Turn the eccentric pin (a) left or right so that the self-diagnostic program "b" just changes to "0" from "1".
10. Re-check the buttonhole lever position when adjustments have been completed.

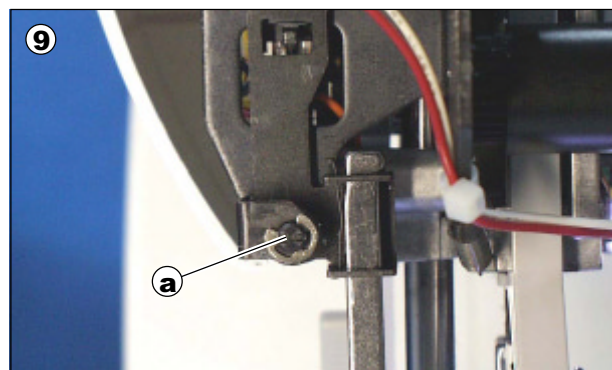
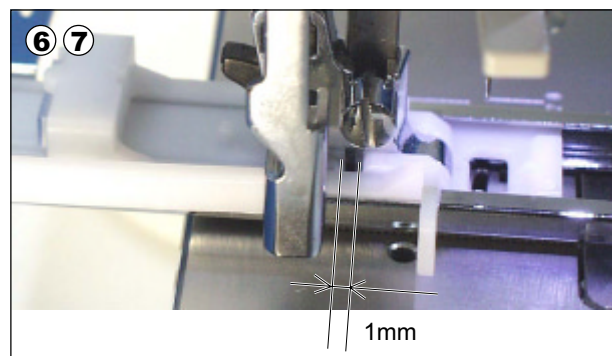

12. MOTOR BELT TENSION

If the motor belt tension is too tight or too loose, machine will not run smoothly.

Adjust as follows:

1. Remove the front enclosure.
2. Loosen the 2 screws (a, b)
3. Move the motor up or downward and tentatively tighten the screws.
Check the belt tension as follows:
 - The belt does not touch to the casting or other parts.
 - The belt must have flexibility of 5-6 mm when average pressure is applied on its side.
4. When correct tension has been obtained, tighten the bolts (a, b) securely.

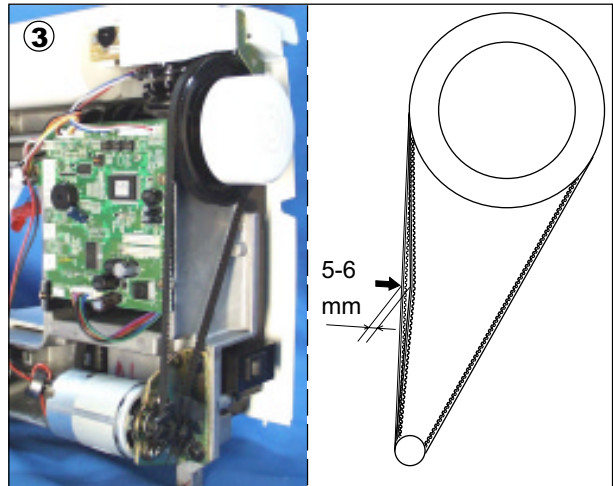
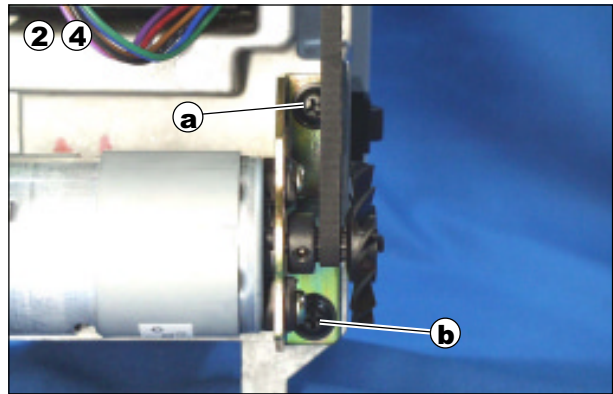

13. TIMING BELT TENSION

If the timing belt tension is too tight or too loose, the machine will run heavily or the timing of hook and feed motion will be changed incorrectly.

Adjust as follows:

1. Remove the front enclosure.
2. Loosen the screw (a) tightening the tension pulley bracket.
3. Push the tension pulley bracket so that the edge of bracket should be 0-1 mm higher than the casting and retighten the screw (a).
4. When you have adjusted the timing belt tension, re-check the timing of the upper and lower shaft (Sec. 6) and the timing of the hook (Sec. 3) again.

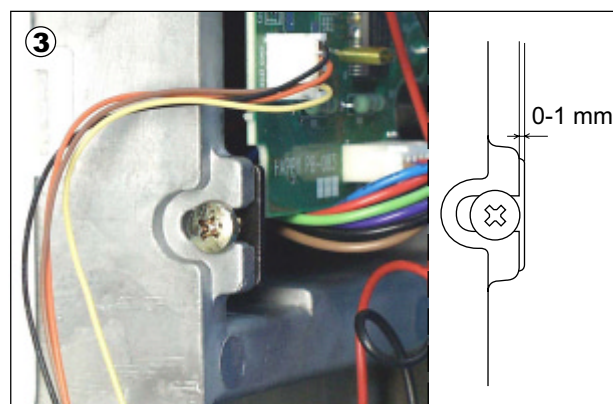
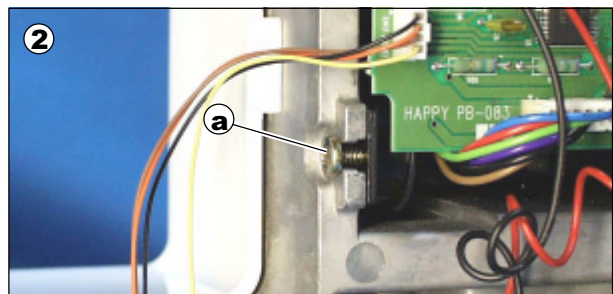

14. BACKLASH OF HOOK GEAR

If there is too much play on the hook gear on the turning direction, it may be the cause for machine not to sew properly and/or making excessive sewing noise.

1. Free play at the tip of hook may be 0-0.5 mm.
If it is not so, adjust as follows.
2. Remove the front enclosure.
3. Loosen the screw (a) and turn the lower shaft eccentric ball bushing up or down by hooking the tip of (-) driver into the left side groove (b) of bushing.
 - Turn upward: The play will increase
 - Turn downward: The play will decrease.
4. Re-tighten the screw (a) tentatively and check that the correct play has obtained.
5. Tighten the screw (a) securely.
6. When you have adjusted the backlash of hook gear, check the timing of the hook again. (Sec. 3)

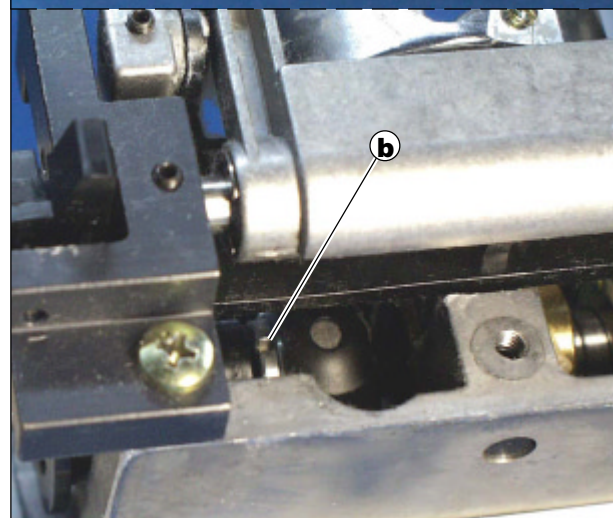
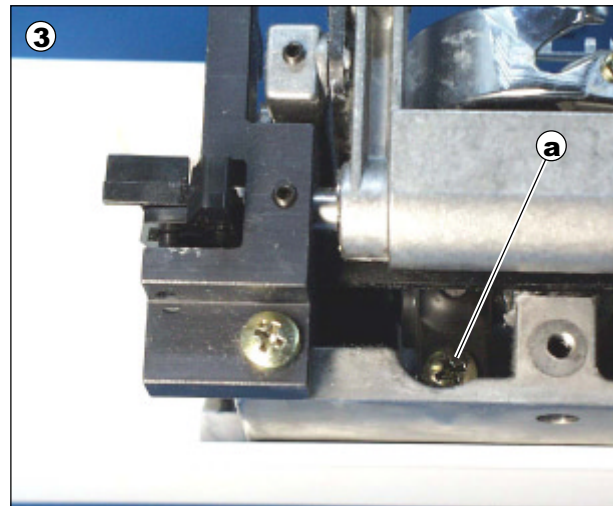
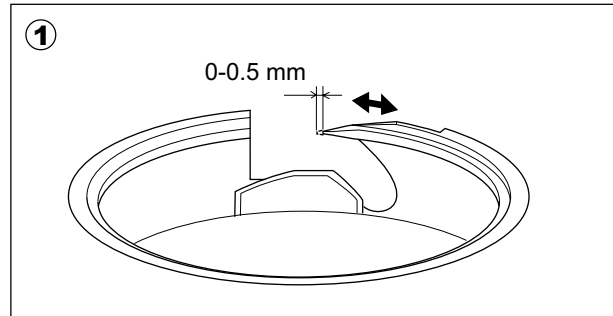

15. UPPER THREAD TENSION UNIT

The upper thread tension regulator unit has been adjusted to the best sewing conditions at the position [AUTO]. However, if you wish to change this, do it as follows:

1. Remove the thread tension cover.
2. Adjust the tension by turning the tension regulator screw (a) either to the front or back.
 - For a stronger tension, turn screw backward
 - For a weaker tension, turn screw frontward.

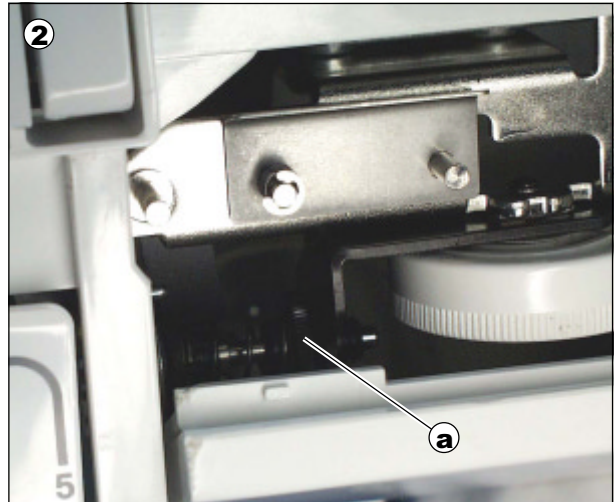

16. ADJUSTING THE LOWER THREAD TENSION

The bobbin thread tension is correctly adjusted at the factory and normally it would not be necessary for you to make adjustments yourself.

If adjustments are necessary adjust as follows.

1. Remove the needle plate.
2. To obtain a weaker bobbin thread tension, turn the screw (a) which is located on the front part of bobbin case counter clockwise, and for a stronger tension, turn screw clockwise.
3. Replace the needle plate.

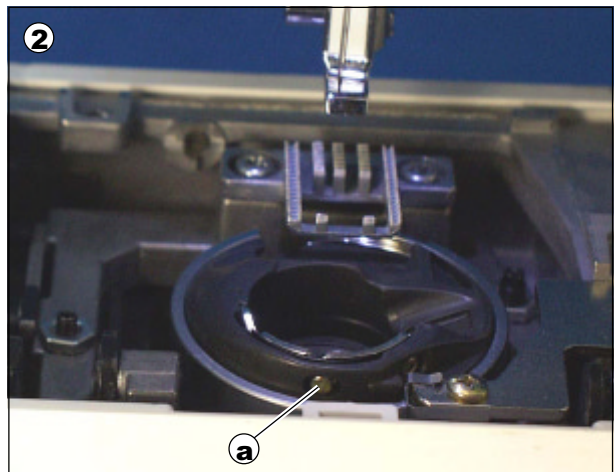

17. FLATNESS OF THE BASE

1. Remove the Extension Table.
2. Place the machine on table.
3. Adjust the height of the rubber feet (c, d) by turning the adjusting screws (a, b) so that the base will be stabilized.

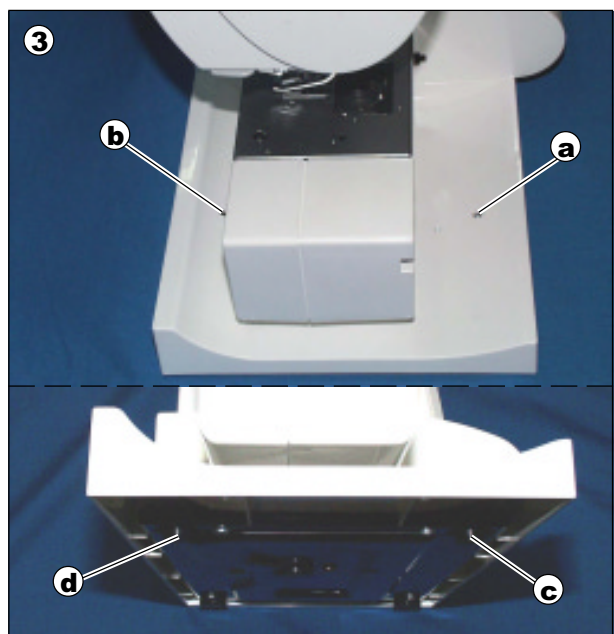

LOCATING THE DEFECTED ELECTRICAL PART

1. To turn off the audible beep

You can operate the machine without the audible beep.

1. Turn off the power switch.
2. Turn on the power switch with pressing the buttons indicated in the right chart.
3. To return the normal mode, turn off the power switch and turn on without pressing any button.

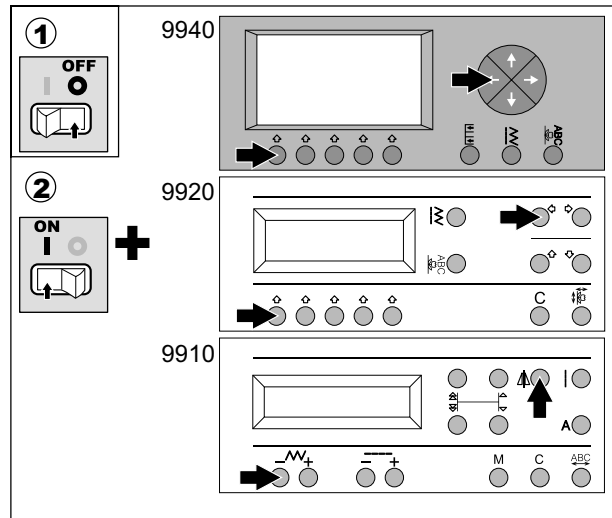

2. The self-diagnostic program

This machine has the self-diagnostic program to locate the defected electronic part.

If your machine functions are not normally, run this program.

1. Turn off the power switch.
2. Turn on the power with pressing the buttons as indicated in the right chart.
3. When this program has started correctly, the LCD will indicate the conditions of each electrical part as below.

* Model 9910 only.

By pressing the Stitch length (+) button, indicating screen will change alternately.

4. See next page to check each electrical part.
5. To quit this program, turn off the power switch.

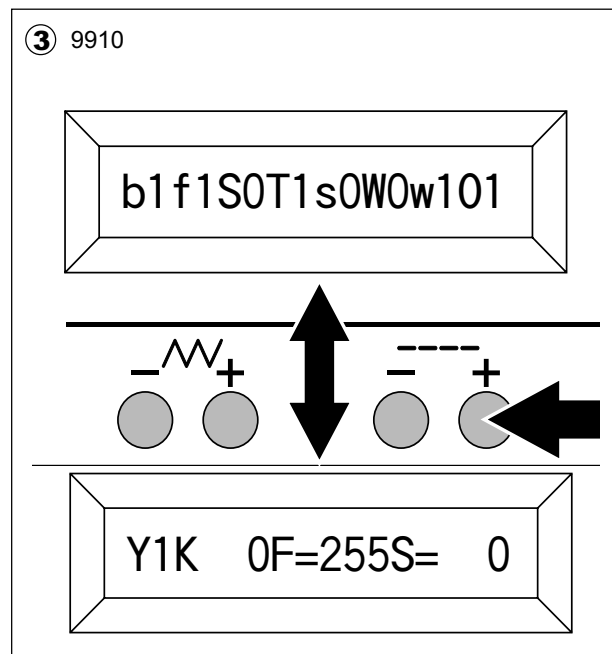
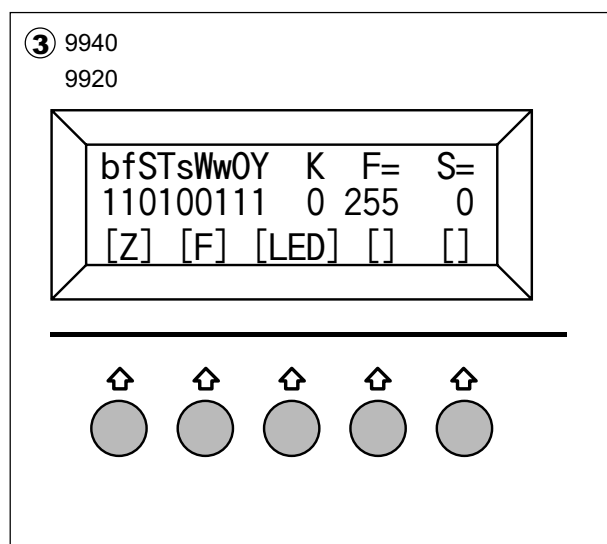
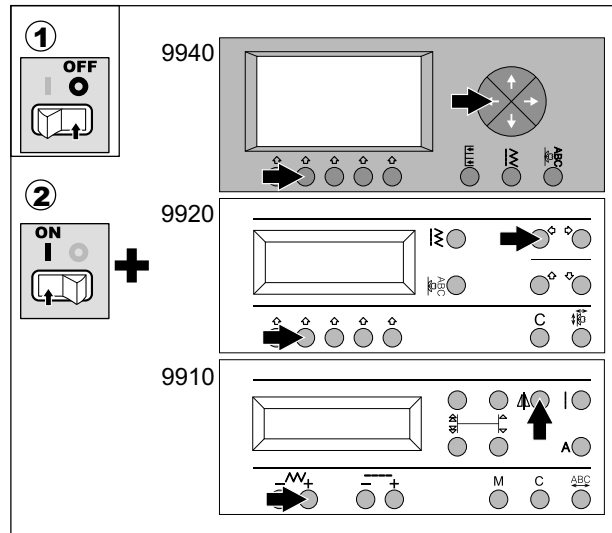

Condition of switches and sensors

The condition of each switch and sensor is indicated as follows.

b: Buttonhole lever switch -Rear

1=Neutral 0=Lever is pulled.

f: Buttonhole lever switch -Front

1=Neutral 0=Lever is pushed.

Lower the buttonhole lever and check these switch by pulling or pushing this lever.

S: Stop sensor 1=not intercepted 0=intercepted

T: Timing sensor 1=not intercepted 0=intercepted

s: Speed sensor 1=not intercepted 0=intercepted

These sensors are intercepted by the slit plates on the upper shaft.

Stop sensor = Stop slit,

Timing sensor = Timing slit,

Speed sensor = Speed slit

Turn the handwheel and check the response of each sensor.

W: Bobbin Winder Switch

1=Bobbin winder spindle is in right position

0=Spindle is in left position

Move the bobbin winder spindle left or right and check this switch.

w: Bobbin Winding Stop Switch

1=Bobbin winder stop is not pushed

(Bobbin winding is not full)

0=Bobbin winder stop is pushed to the right

(Bobbin winding is full.)

Move the bobbin winder stopper to the right and check this switch.

O: Presser foot switch

1=Presser foot is lowered

0=Presser foot is lifted

Lower or lift the presser foot lifter and check the response of this switch.

Y: Upper thread sensor (Only 9940)

1=Thread check spring is pulled

0=Thread check spring is not pulled

Thread the upper thread until thread check spring (threading route No. 4) and hold both end of thread. Pull or release left end of thread and check the response of this sensor.

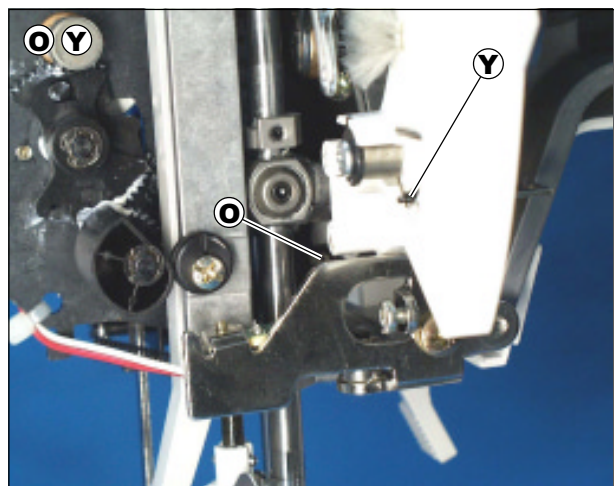
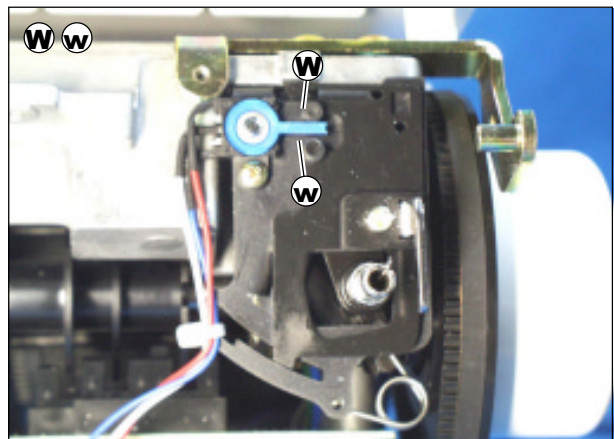
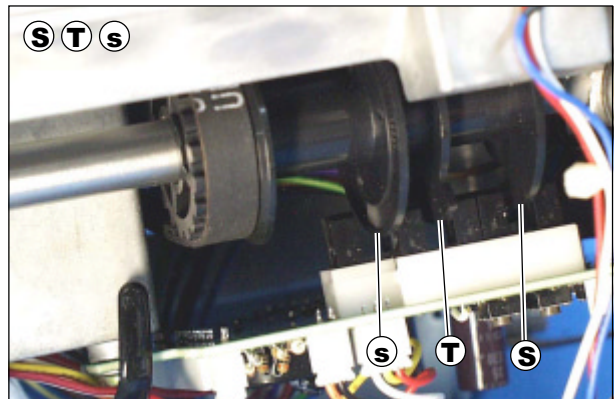
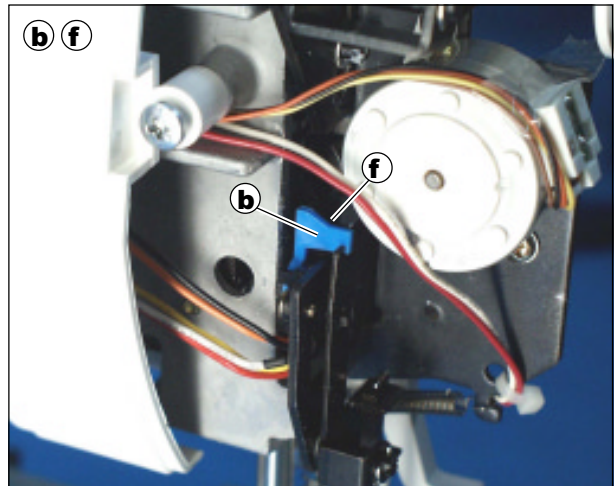

K: Response of each button

By pressing each button, number will be indicated as below.

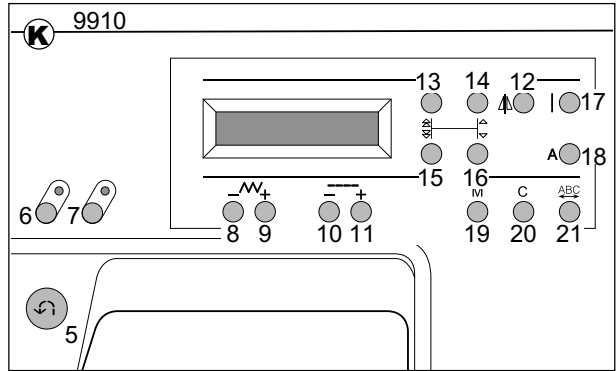
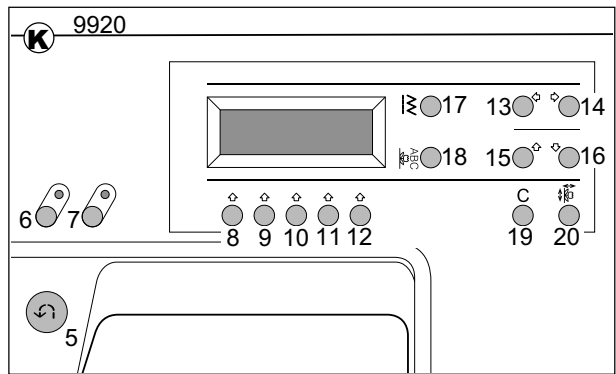
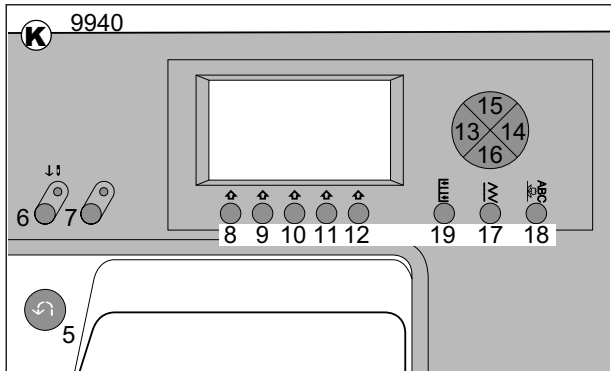

F: Condition of Foot Controller

Foot controller is not connected : the number 255 will appear.

Connect the foot controller : the number will change to 75.

Press the pedal of controller : the number will decrease according to the pressure on the pedal. When pressed maximum, the number 0 will be indicated.

S: This is not used these models.

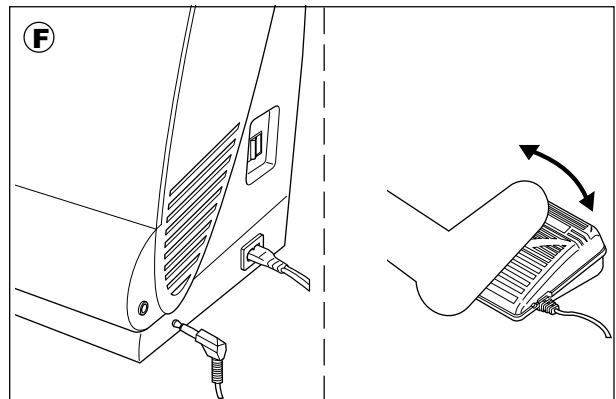

Checking Starting point of Z and F pulse motors

1. When self-diagnostic program is running;

- By pressing the button (a), Z pulse motor will move to starting point.
- By pressing the button (b), F pulse motor will move to starting point.

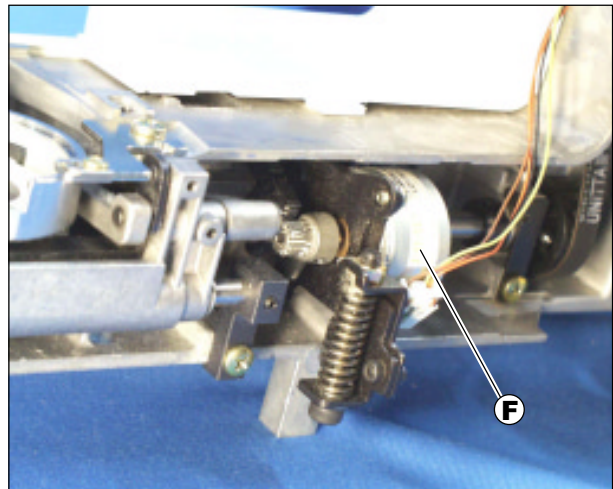
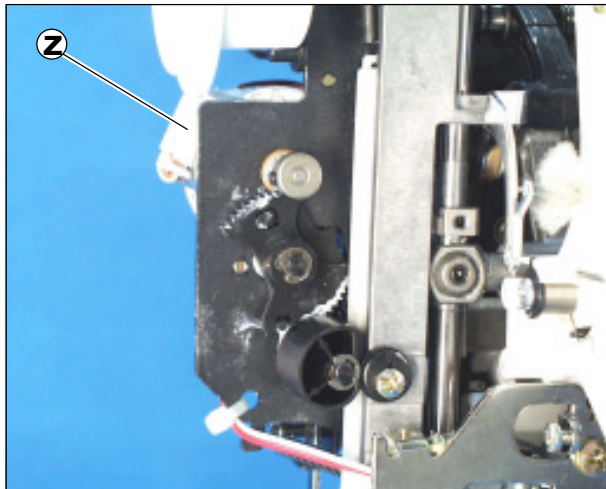
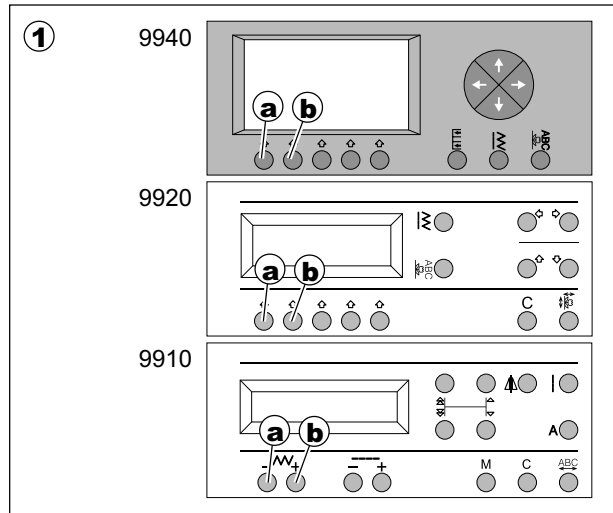

Checking LED Light

1. When self-diagnostic program is running;

- By pressing the button (c) once, LED (d) will turn on.
- By pressing the button (c) again, LED (e) will turn on.
- By pressing the button (c) once more, LED will turn off.

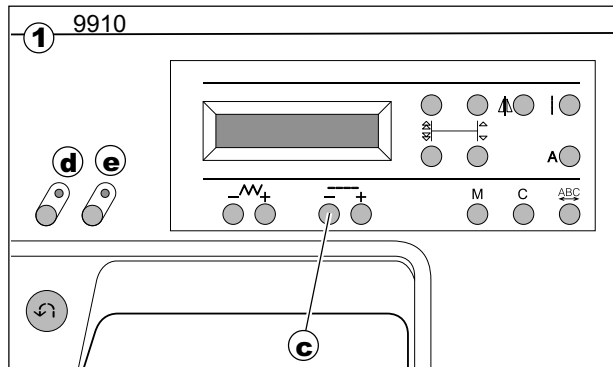
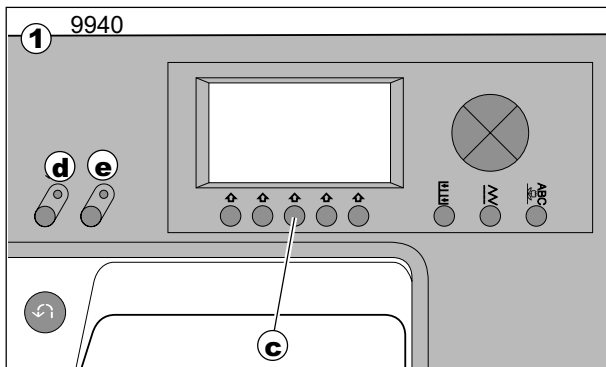
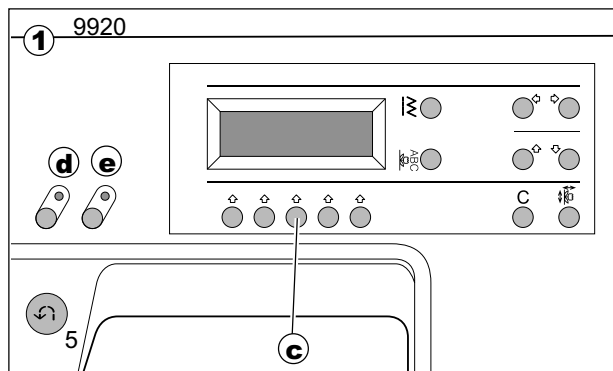

3. Messages on LCD (9940/9920)

1. Winding the bobbin.
2. Lower the buttonhole lever.
3. Raise the presser foot lifter and set the buttonhole foot to correct position.
4. Release the foot controller pedal.
5. Lower the presser foot.
6. Machine cannot memory any more.
7. Select pattern.
8. Release the reverse button.
9. Rethread the upper thread (9940 only)
10. Release the needle up/down button.

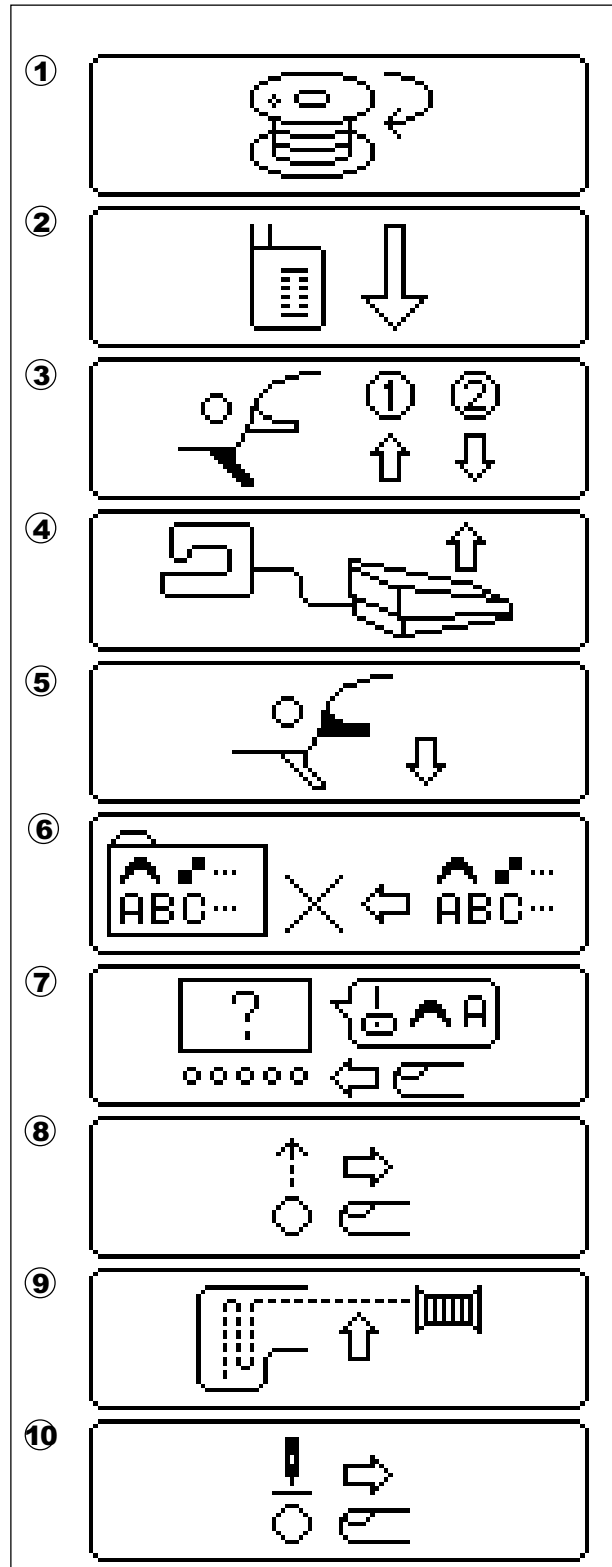

4. Electrical Parts Connection

- a. CPU Board
- b. Power Circuit Board
- c. Power Switch Assy.
- d. Terminal Box Assy.
- e. Motor
- f. F Pulse Motor
- g. Z Pulse Motor
- h. LED Board Assy.
- i. BH Switch Assy.
- j. Presser Foot Switch Assy.
- k. Thread Sensor Board Assy. (9940 Only)
- l. Reverse Switch Board Assy.
- m. LCD Assy.
- n. Contrast Control Board Assy.
- o. Display Board Assy.
- p. Controller Jack Assy.

