

XL711S,471,771,461,761,721  
M461,114,606,607

how to use  
and enjoy your  
**sewing  
machine**

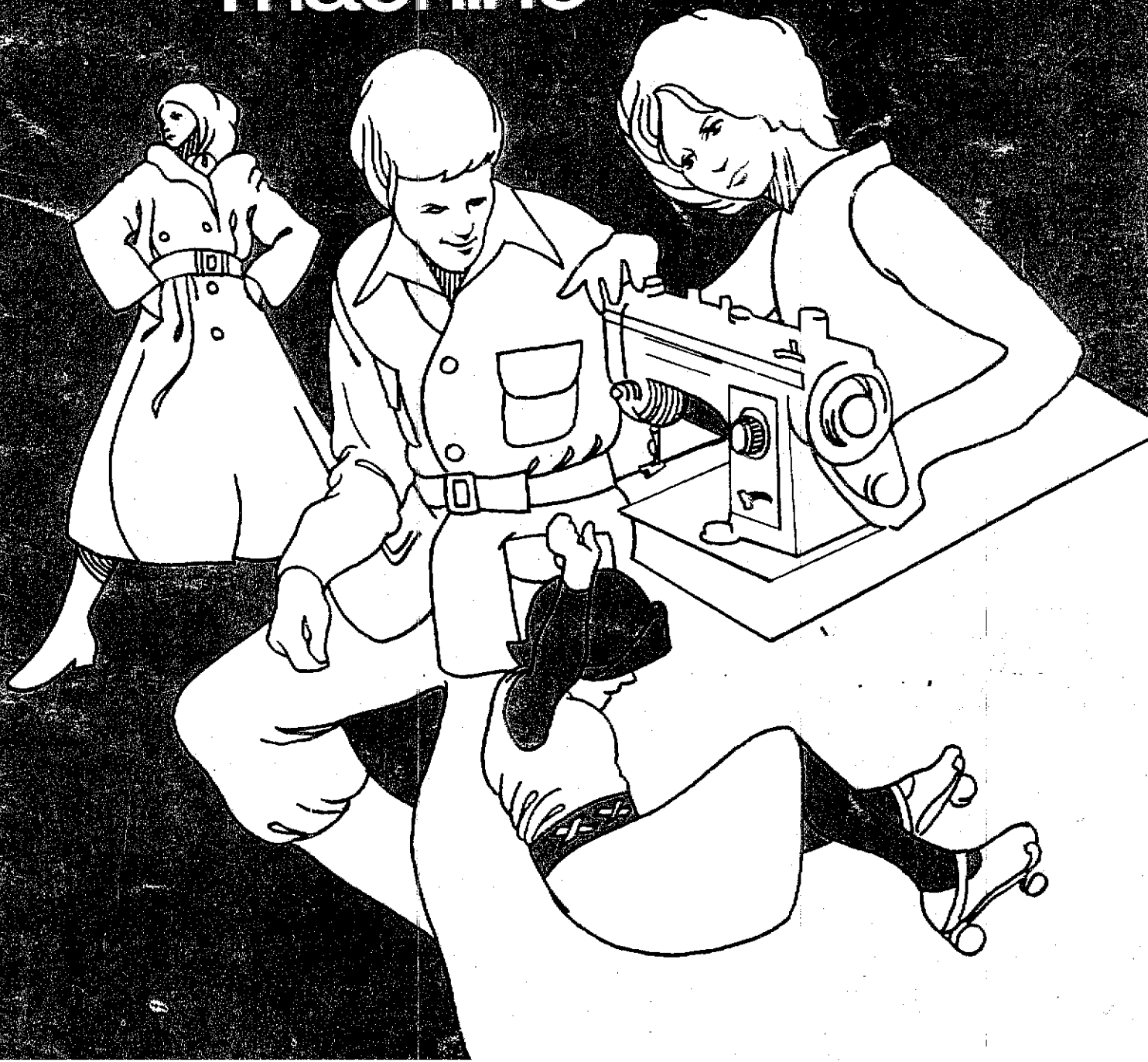

IMPORTANT MESSAGE RELATED TO STRETCH FABRIC SEWING

The "GOLDEN STRETCH STITCH NEEDLE"<sup>®</sup>

Since the popularity of stretch fabrics continues to grow, this company has developed a special "GOLDEN STRETCH STITCH NEEDLE" and has provided you with a supply in your accessory box. This innovation means that you can sew on any type of stretch fabric with the same needle, no change necessary regardless of which stretch fabric you select.

With the "GOLDEN STRETCH STITCH NEEDLE" you will never skip stitches and used with this precision built sewing machine your sewing will always be neat and professional on the most advanced fabric of today.

# CONTENTS

## 1 Knowing the Outline of Your Sewing Machine 2

PRINCIPAL PARTS .....	2
ACCESSORIES .....	4
INSTALLING MACHINE HEAD .....	5
UPPER (NEEDLE) THREAD .....	6
LOWER (BOBBIN) THREAD .....	7
To wind bobbin .....	7
To remove bobbin case .....	8
To thread and insert bobbin case .....	8
To pull up lower thread .....	9
NEEDLE .....	9
To change the needle .....	9
To check the needle .....	9
Twin needle .....	10
Golden stretch stitch needle .....	10
RELATIVE CHART OF SEWING MATERIAL, NEEDLE AND THREAD .....	11
PRESSER FOOT .....	11
NEEDLE PLATE .....	12
SEW-LIGHT .....	12
VARIOUS CONTROLS .....	13
Stitch length .....	13
Zigzag width .....	13
Reverse stitch .....	14
Needle position .....	14
Height of feed dog .....	14
Pattern selection .....	15
Pattern indicator plate .....	16
Thread tensions .....	17

## 2 Straight Stitching 19

To start sewing .....	19
To change the sewing direction .....	19
To fasten the final sewing .....	20
To remove the work .....	20
To guide and support the material .....	20

## 3 Zigzag Stitching 21

Simple zigzag stitch .....	21
Satin stitch .....	21

## 4 Using Built-in Patterns 22

Buttonholes .....	23
Triple stretch stitch .....	25
Blind stitch .....	25
Elastic stitch (Three step stitch) .....	26
Shell stitch .....	27
Scalloping .....	27

## 5 Using Attachments 28

Button fitting .....	28
Narrow hemming .....	29
Zipper insertion .....	30
Darning .....	31
Using cloth guide .....	31

## 6 Making More Stitches 32

Gathering .....	32
Overlock .....	32
Appliqueing .....	33
Cording .....	33
Monogramming .....	34
Embroidering .....	35

## 7 Maintenance and Care for the Machine 36

CLEANING .....	36
Taking out the hook .....	36
Cleaning of shuttle race .....	36
Cleaning of feed dog .....	36
OILING .....	37
CHECK LIST FOR BETTER SEWING .....	38

# Knowing the Outline of Your Sewing Machine

## Principal Parts

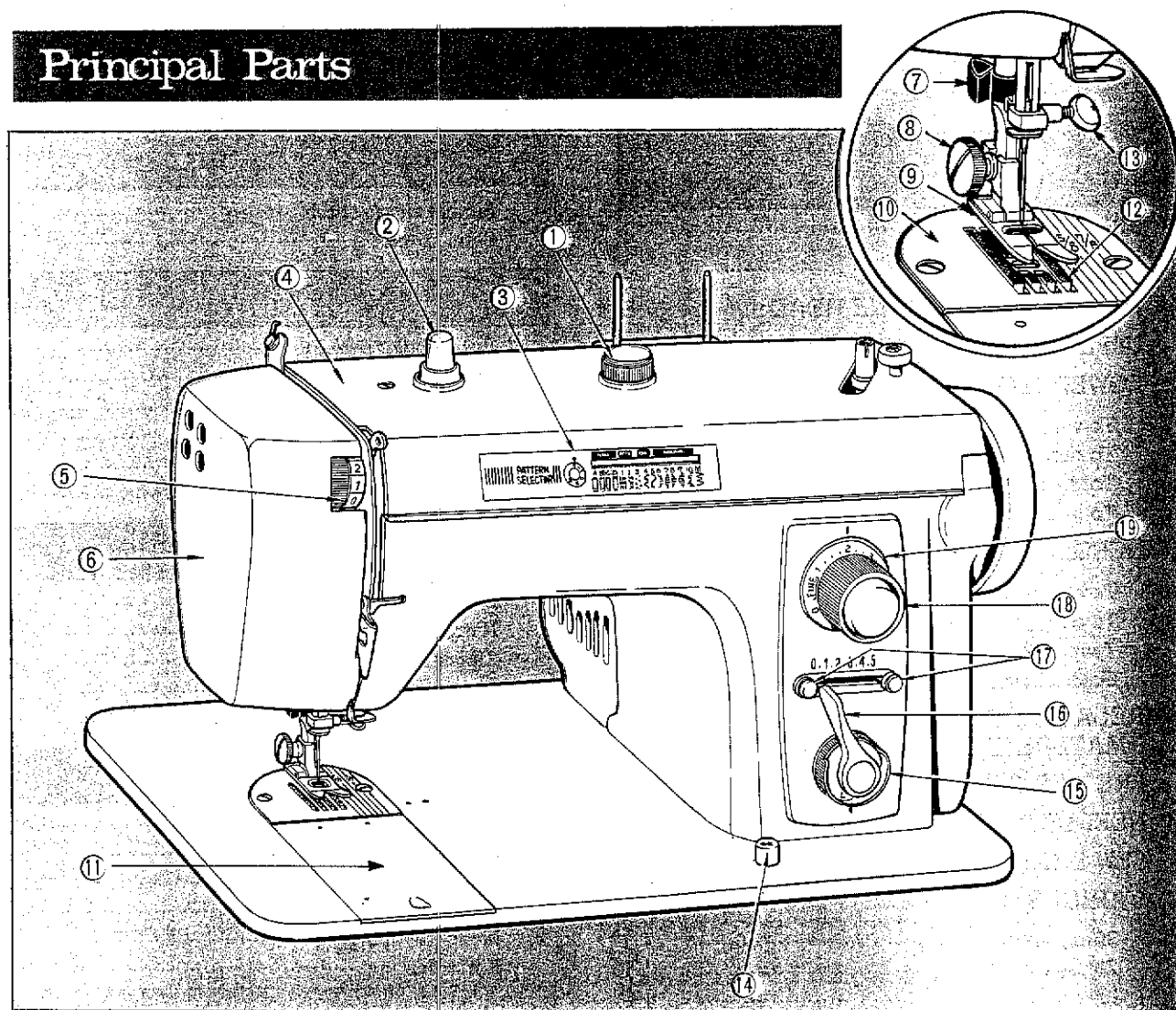

1. Pattern Selection Knob

Turning this knob, you will obtain wide variety of decorative and utility stitches, such as blind stitch, stretch stitch and buttonhole. (See page 15)

2. Pattern Selection Push Button

While pushing this button to turn the Pattern Selection Knob.

(See page 15)

3. Pattern Indicator Plate (See page 16)

4. Top Cover

5. Thread Tension Dial (See page 17)

6. Face Plate

7. Thread Cutter

8. Presser Foot Screw

9. Presser Foot (Zigzag) (See page 12)

10. Needle Plate (Zigzag)

This Needle Plate can be removed easily for replacement. (See page 12)

11. Slide Plate

12. Feed Dog (See page 14)

13. Needle Clamp Screw

14. Drop Feed Push Button

To regulate the height of feed dog, push this button. (See page 14)

15. Needle Position Selector

The needle swings

at L : from left to right

M : from middle to right and left

R : from right to left

(See page 14)

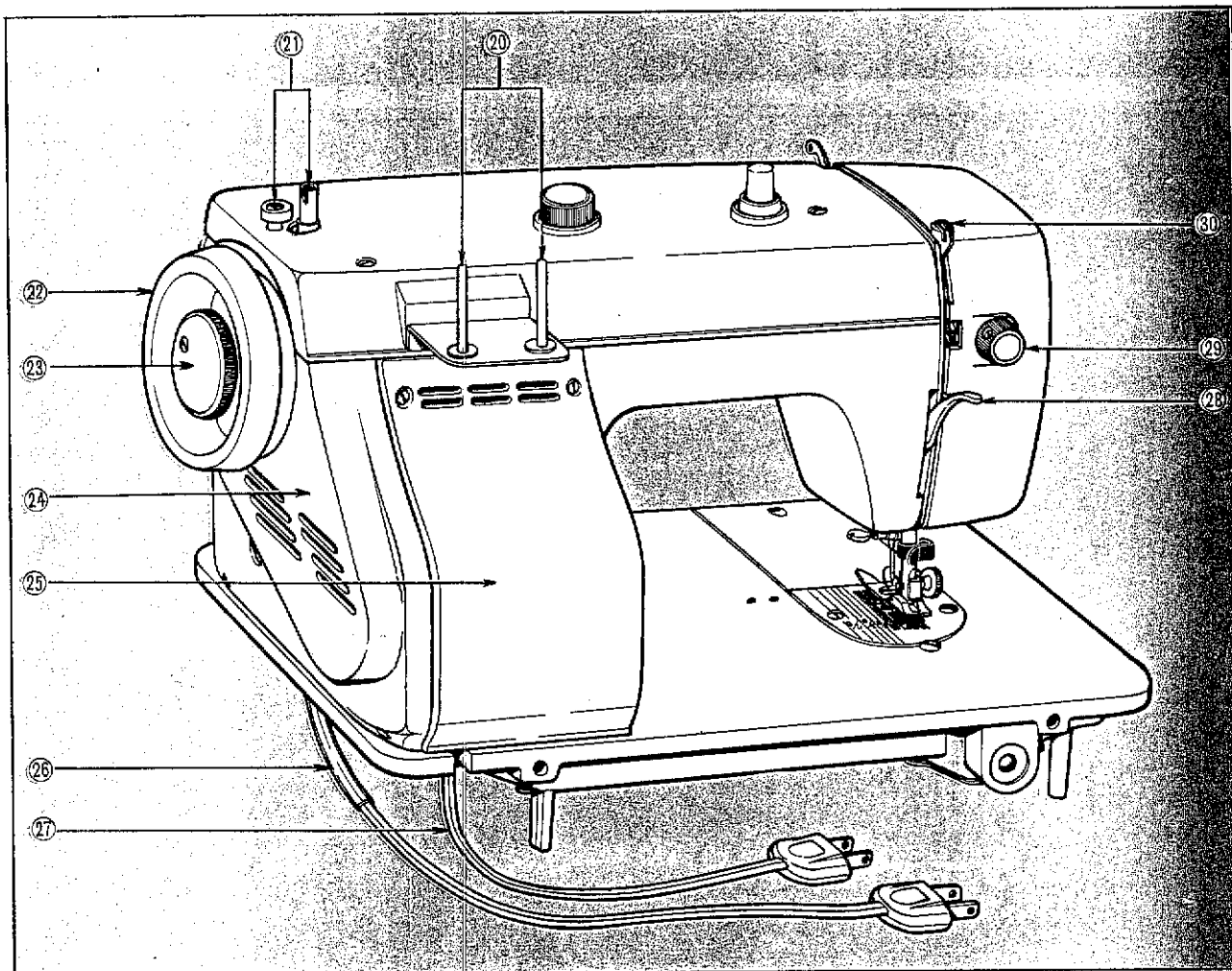

- |   |  |
|---|--|
| <p>16. Zigzag Width Lever<br/>To make the zigzag stitches, turn this lever to the right according to the numerals above the lever which represent the width of zigzag stitch.<br/>(See page 13)</p> <p>17. Zigzag Width Lever Stoppers<br/>These are used for regulating the movement of Zigzag Width Lever.<br/>(See page 13)</p> <p>18. Reverse Sewing Button (See page 14)</p> <p>19. Stitch Length Dial<br/>By turning this dial, you can control the length of the stitch. The higher the number, the longer the stitch.<br/>(See page 13)</p> <p>20. Spool Pins</p> | <p>21. Bobbin Winder Device</p> <p>22. Balance Wheel</p> <p>23. Stop Motion Knob</p> <p>24. Belt Cover (Built-in Motor Type)</p> <p>25. Motor Cover (Built-in Motor Type)</p> <p>26. Sew-light Cord</p> <p>27. Motor Cord</p> <p>28. Presser Foot Lifter<br/>When the presser foot is at the highest position, the tension on the upper thread is released.</p> <p>29. Sew-light Switch<br/>Turn this knob in any direction to switch light on and off.</p> <p>30. Thread Guide and Bobbin Winder Tension Disc</p> |
|---|--|

## Accessories

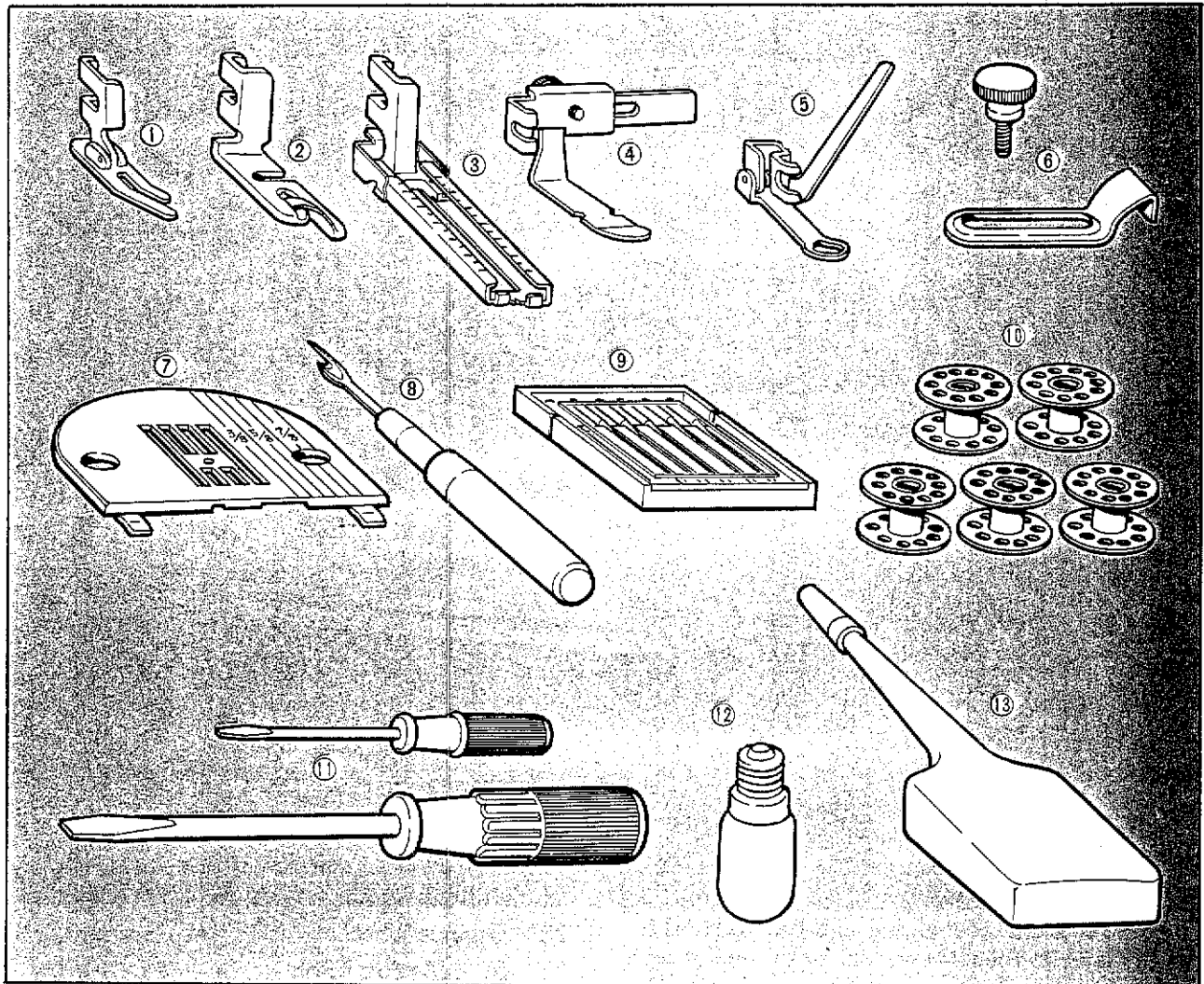

1. Straight Stitch Foot
2. Narrow Hemmer Foot  
(See page 29)
3. Buttonhole and Button Sewing Foot  
(See page 23 & 28)
4. Zipper Foot  
(See page 30)
5. Darning Foot  
(See page 31)
6. Cloth Guide with Screw  
(See page 31)
7. Straight Stitch Needle F

8. Seam Ripper
9. Needles  
Single Needle, No. 14 (3 pcs.)  
Golden Stretch Stitch Needle (2 pcs.)  
Twin Needle (1 pce.)  
(See page 9 & 10)
10. Bobbin (5 pcs.)
11. Screw Drivers (large and small)
12. Sew-light Bulb  
(See page 12)
13. Oiler

## Installing Machine Head

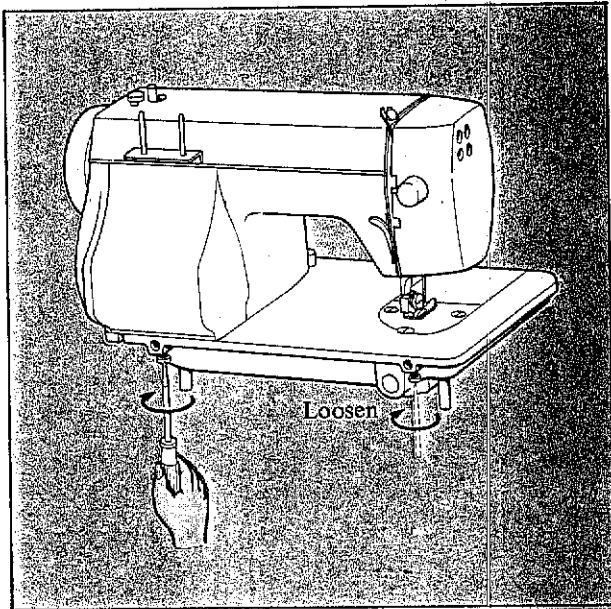

1. Loosen two set screws to permit hinge pins located in the back of the cabinet or base of portable case to enter.

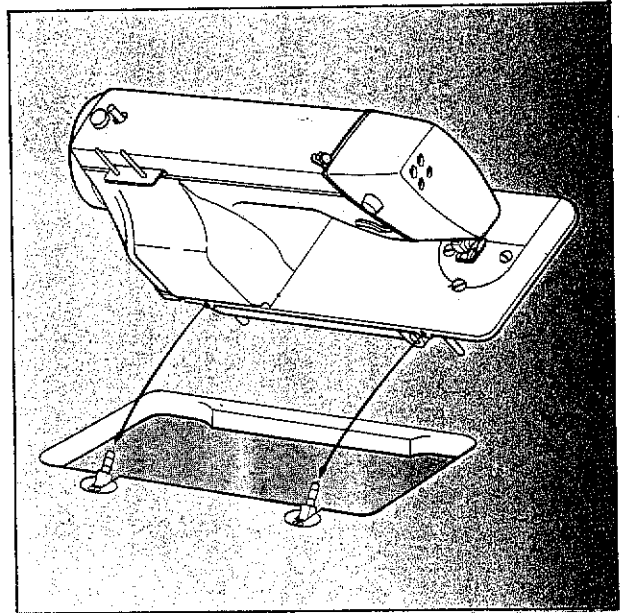

2. Insert hinge pins into openings at the back of sewing machine bed.

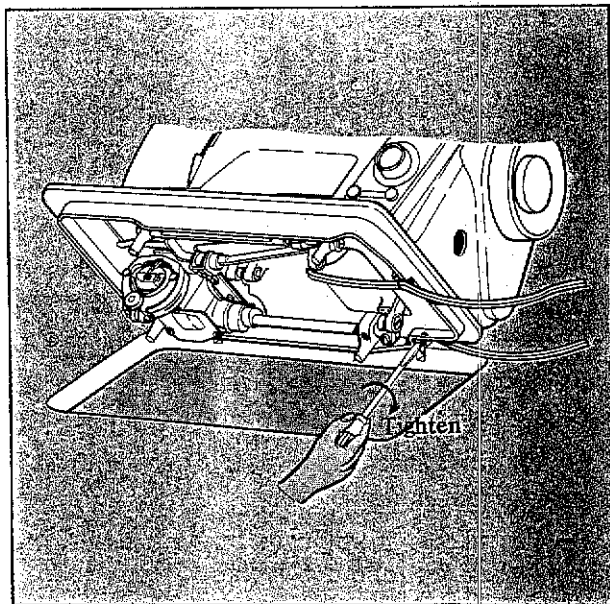

3. Tighten set screws securely.

"Never use machine unless it is in case or cabinet as bottom of machine is open."

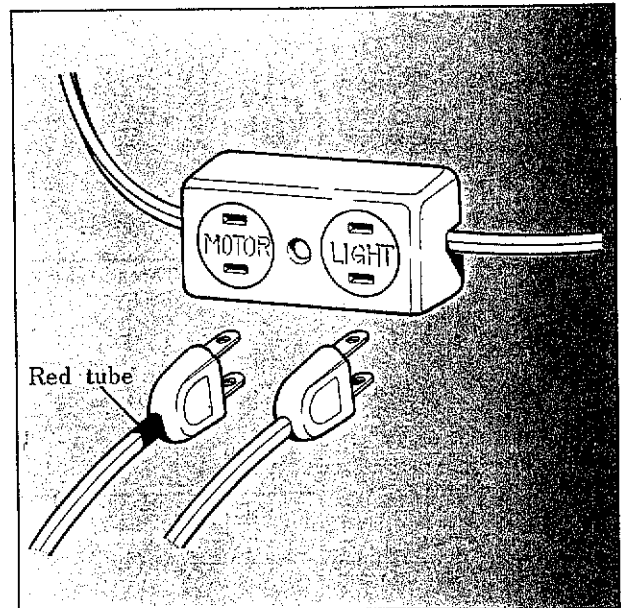

4. Connect two-pin plugs leading from the motor with red tube and the sew-light to the electrical outlets made "MOTOR" and "LIGHT" respectively. Then plug the cord leading from the cabinet or base of portable case into wall outlet.

# Upper (Needle) Thread

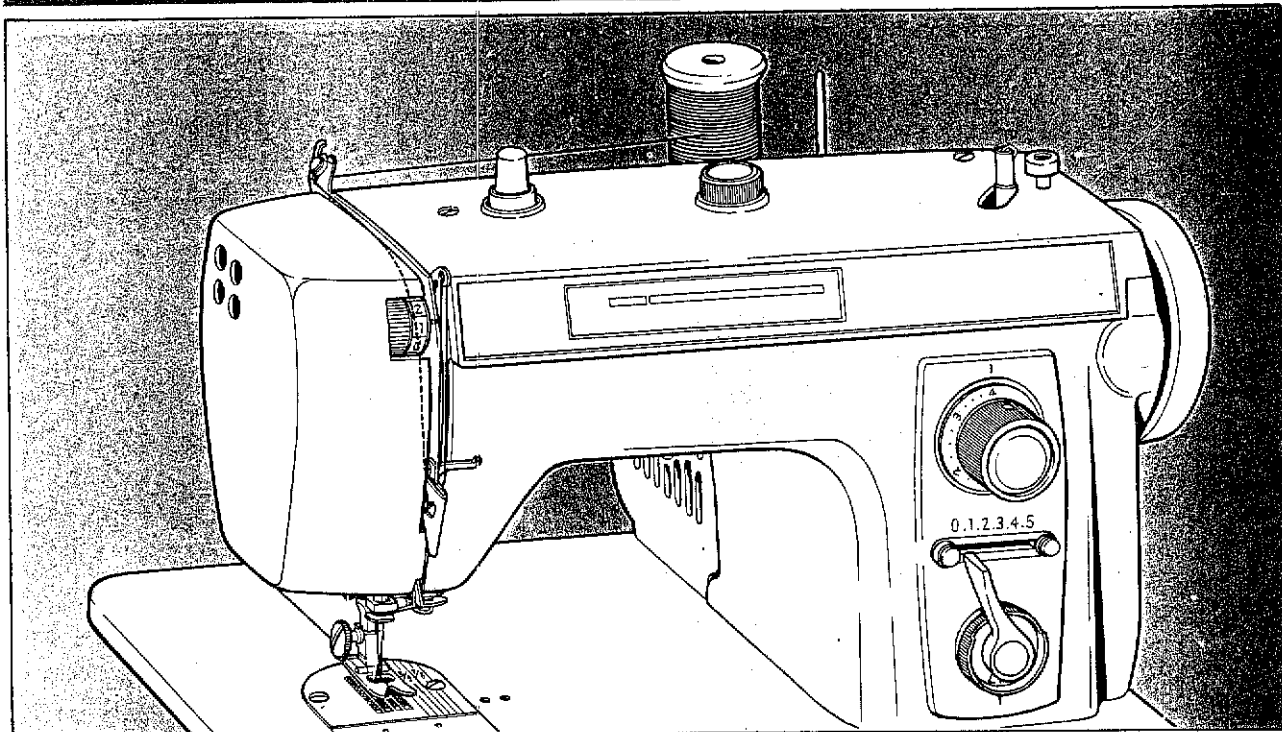

1. Upper thread guide

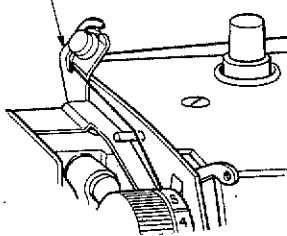

2.

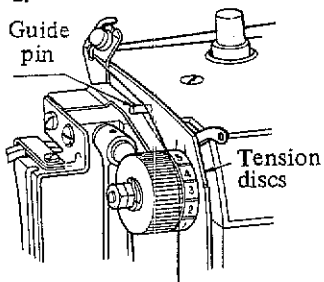

3.

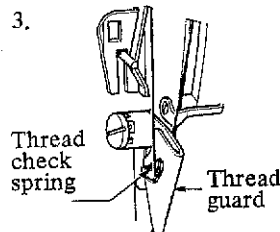

4.

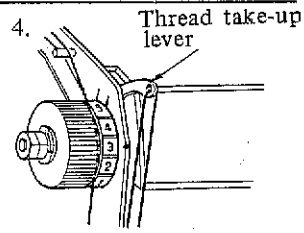

5.

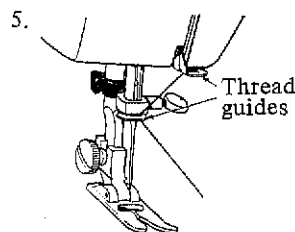

6.

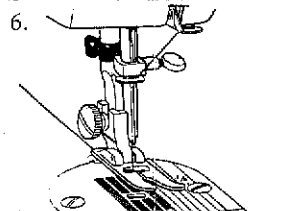

Before threading, make sure to raise presser foot and take-up lever to the highest position. Then place spool of thread on the spool pin.

1. Pass thread through the eye of upper thread guide.
2. Pass thread between upper thread tension discs from the upper side of guide pin.
3. Bring thread down and up through thread guard from left to right so that thread picks up the thread check spring.
4. Pass thread into the eyelet of the thread take-up lever from left to right.
5. Bring down again and pass thread through the thread guides.
6. Thread needle from front to back and draw the thread out about 6 inches.

**NOTE:** If the threading order is not correct, thread breakage, stitch skipping, wrinkling of fabric will occur.



# Lower (Bobbin) Thread

## TO WIND BOBBIN

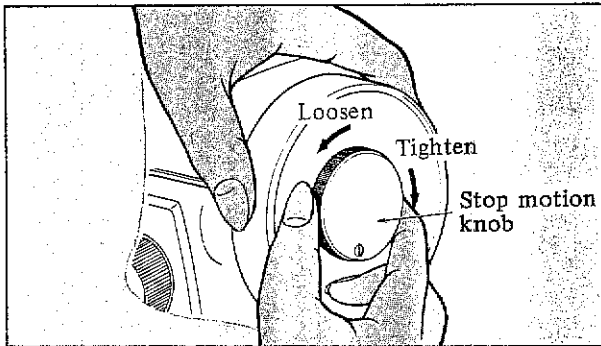
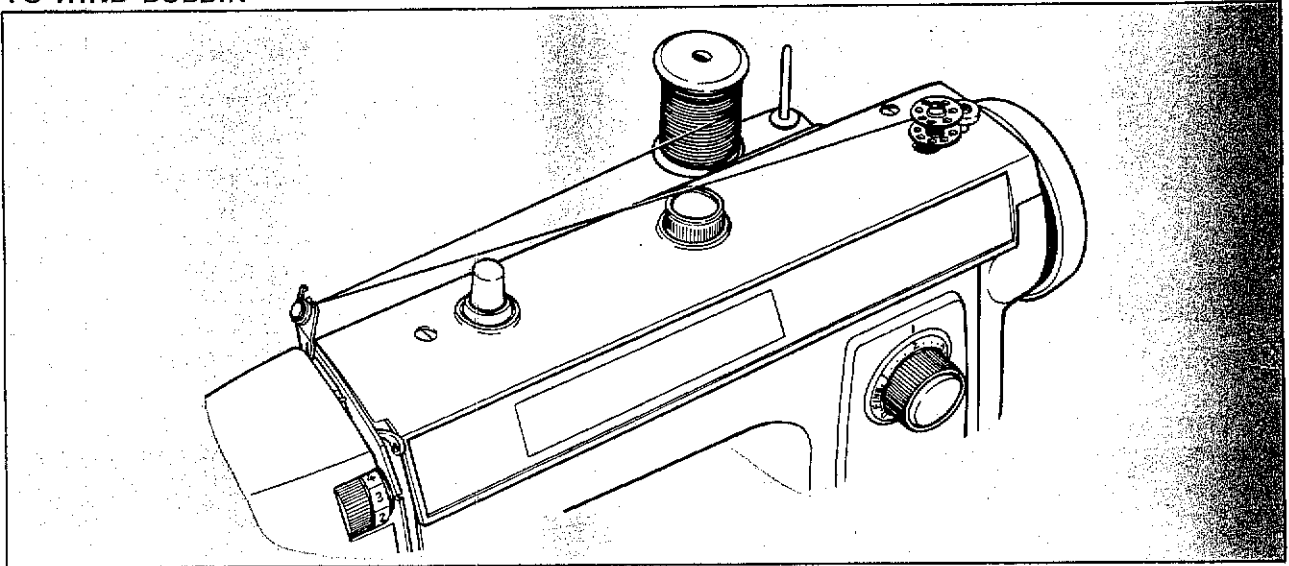

1. Loosen stop motion knob by turning it toward you.

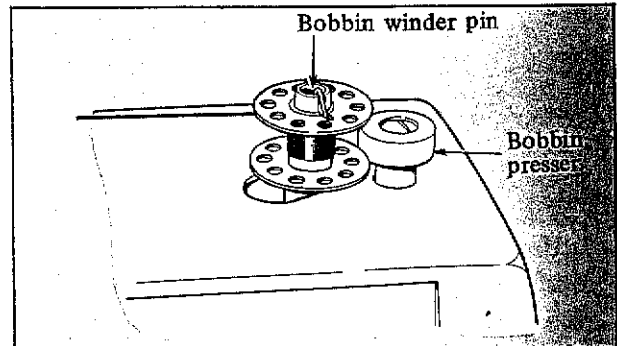

2. Place an empty bobbin on the bobbin winder pin.

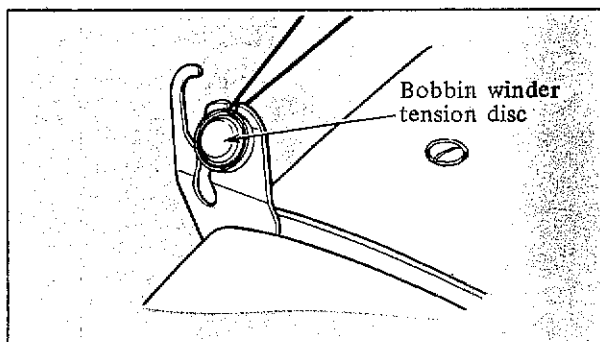

3. Place thread spool on the spool pin and take thread through bobbin winder tension disc.

4. Wind the thread a few times around the bobbin clockwise and push the bobbin toward bobbin presser. Start the machine gently.

5. When bobbin thread is full, it stops the winding.

6. Push the bobbin to the left and remove it. Tighten stop motion knob securely.

## TO REMOVE BOBBIN CASE

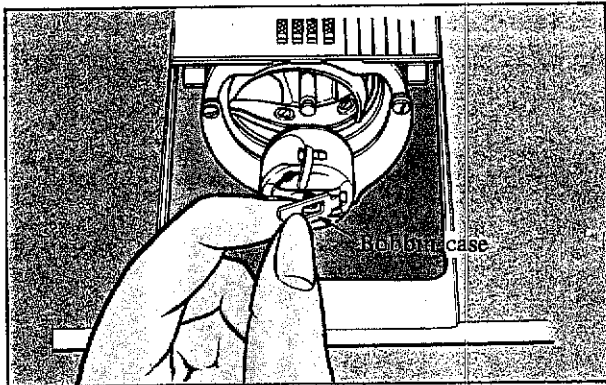

1. Raise needle to its highest position.
2. Pull slide plate toward you.
3. Pull and open the latch of bobbin case.
4. Pull out bobbin case from the shuttle.

## TO THREAD AND INSERT BOBBIN CASE

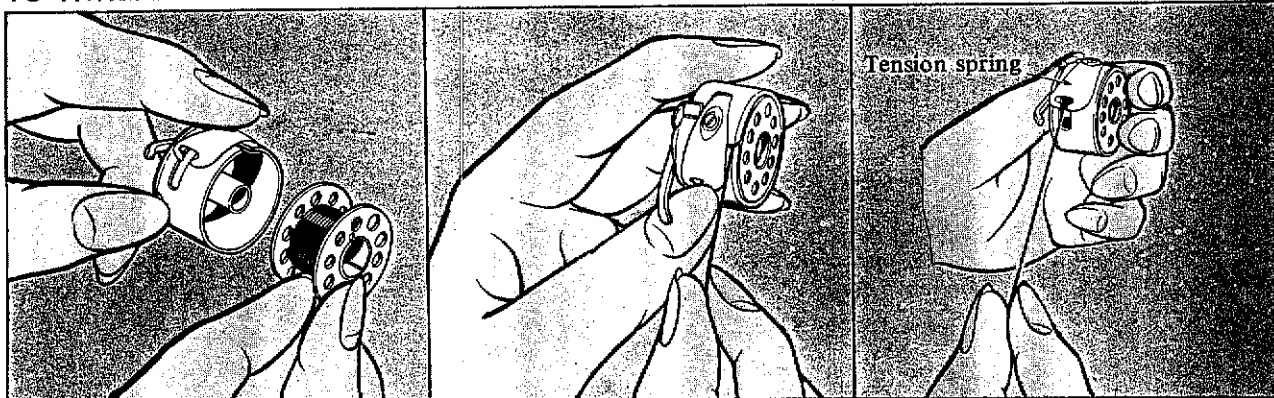

1. Unwind about 3 or 4 inches of thread from the bobbin. Insert wound bobbin into bobbin case.
2. Pull trailing thread into the slot of case.
3. Pull thread to the left under the tension spring until thread enters into delivery eye.

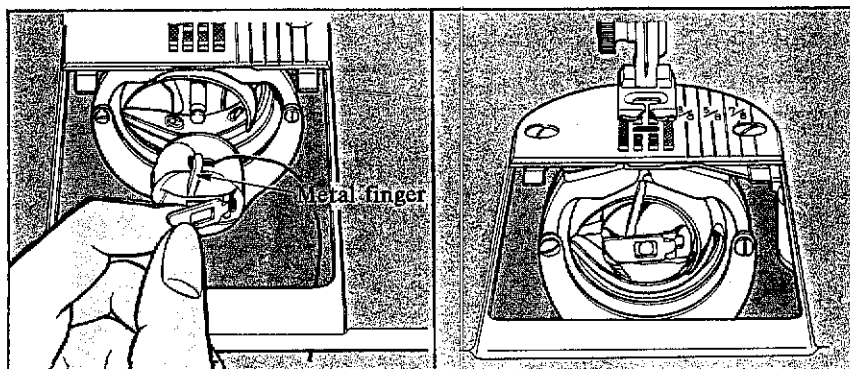

4. Holding bobbin case latch with the metal finger of case pointing up, fit it into the notch at the top of the shuttle race.
5. Release latch and push case back making sure the case is in the proper position. Close slide plate.

NOTE: The thread drawn out of the case is to be left hanging below the race. Leave about 5 - 6 inches hanging.

### TO PULL UP LOWER THREAD

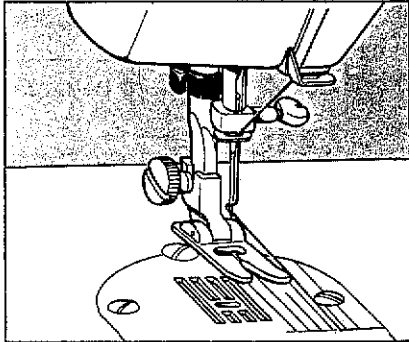

1. Raise needle and presser foot to the highest point. With left hand, hold the end of upper thread and with right hand, turn balance wheel toward you until the needle moves down and up again to its highest position.

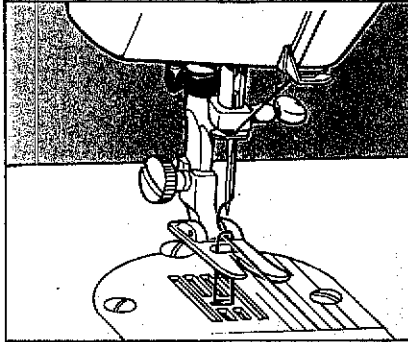

2. Now upper thread catches the lower thread in a loop. Pull upper thread toward you so that lower thread will come up in a large loop from the presser foot.

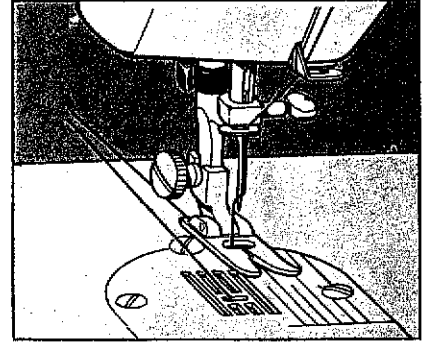

3. Pull both threads under the toes of presser foot and place them to the rear leaving about 3 - 4 inches.

## Needle

### TO CHANGE THE NEEDLE

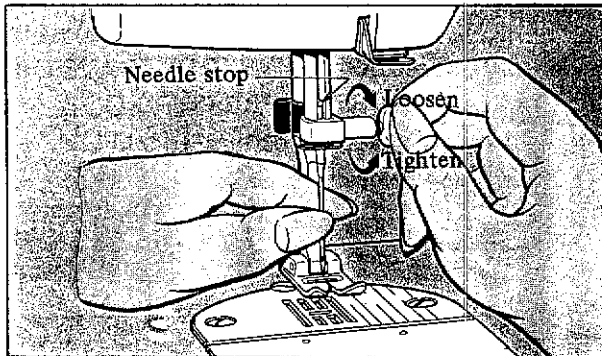

1. Raise needle to its highest position.
2. Loosen needle clamp screw and remove old needle.
3. Insert new needle up into needle clamp hole as far as it will go against the needle stop. Make sure the flat side of needle faces toward the back side and the long groove toward you.
4. Tighten needle clamp screw securely.

### TO CHECK THE NEEDLE

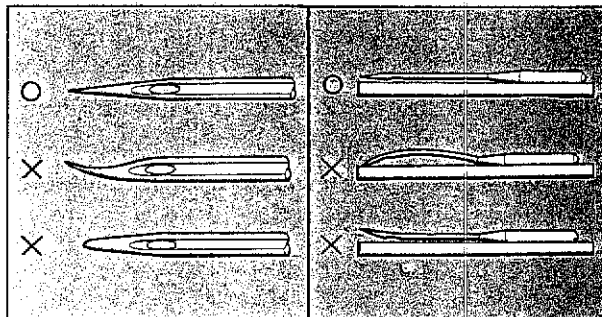

The sewing needle must be always straight and sharp to have smooth sewing.

To check if the needle is bent, the flat side of the needle down on a slide plate as shown in figure.

## TWIN NEEDLE

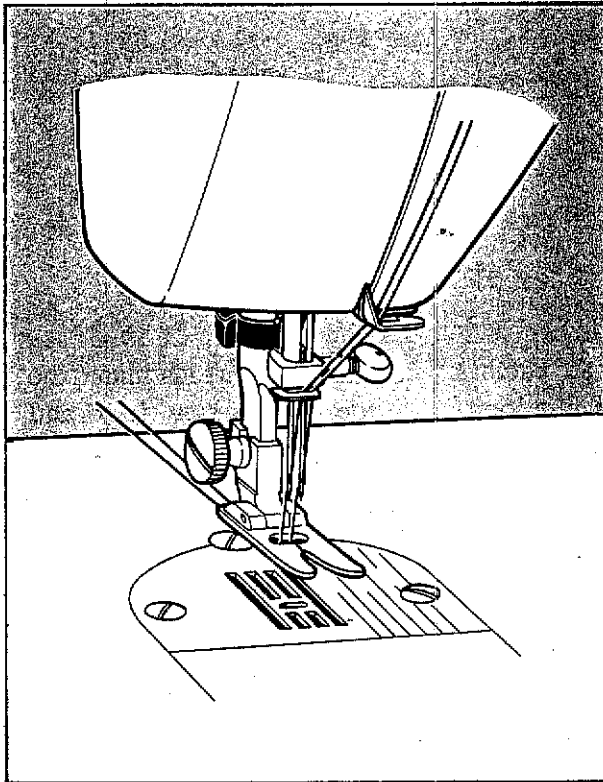

Your sewing machine is especially constructed for optional twin needle sewing.

You can use either one or two colors of upper thread.

When you use twin needle, use the same size threads (No. 50 - 80 mercerized thread recommended), and make sure the weight of two spools of thread are equal, otherwise the stitch will be faulty.

### \* INSERTION OF TWIN NEEDLE :

In the same manner as for the single needle, make sure that the flat side of needle faces toward the back side and long groove faces toward you.

### \* THREADING OF TWIN NEEDLE :

Follow instructions for single needle threading but thread each needle separately from front to back.

**NOTE:** When you use twin needle, make sure of the following machine settings.

1. Use ZIGZAG NEEDLE PLATE.
2. Use ZIGZAG PRESSER FOOT.
3. Set needle position to "M".
4. Set zigzag width UNDER 3.

## GOLDEN STRETCH STITCH NEEDLE®

For sewing on the popular stretch variety of fabrics you will want to use our exclusive "GOLDEN STRETCH STITCH NEEDLE".

This wonder needle can sew perfectly on any type of stretch fabric such as, knits tricots, jersey, polyester etc.

You will find two "GOLDEN STRETCH STITCH NEEDLES" in the needle pack included in your accessory box

Now, you will never have skipped stitches on stretch fabrics when you use this universally suitable special needle.

## Relative Chart of Sewing Material, Needle and Thread

SEWING MATERIAL		NEEDLE SIZES	THREAD SIZES
VERY THIN	Fine tricot, Fine lace, Thin linen, Silk, Tulle, Chiffon	9	Cotton: 80 - 120 Synthetic Fine Mercerized Cotton
LIGHTWEIGHT	Organdy, Jersey, Voile, Taffeta, Synthetics, Silk, Batiste.	11	Cotton: 60 - 80 Silk: "A" Synthetic Mercerized 50
MEDIUM	Cotton, Gingham, Poplin, Percale, Pique, Satin, Velvet, Lightweight wool, Fine corduroy, Suitings	14	Cotton: 50 - 60 Silk: "A" Synthetic Mercerized 50 - 60
HEAVY	Denim, Gabardine, Tweed, Corduroy	16	Cotton: 40 - 50 Mercerized Heavy Duty
VERY HEAVY	Canvas, Overcoatings, Upholstery	18	Cotton: 30 - 40 Mercerized Heavy Duty

- NOTE:
1. Thread should be always thinner than the needle eye.
  2. Use the same size and type for both lower and upper threads.
  3. Needle must be sharp to pierce into and out of the materials.

## Presser Foot

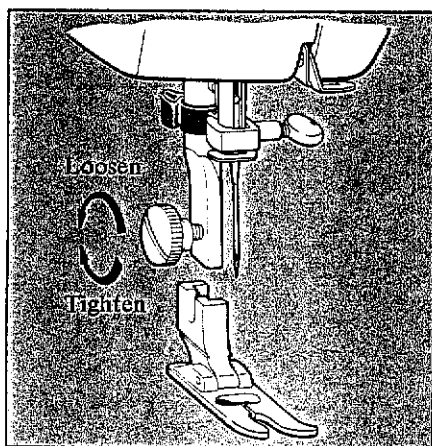

You will find various kinds of presser foot for special use in the accessory box.

According to your sewing needs, it may be necessary to change presser foot as follows.

1. Raise needle to its highest position.
2. Raise presser foot.
3. Loosen presser foot thumb screw and remove presser foot.
4. Place grooved side of the new presser foot against the flat of the presser bar.
5. Push foot up and tighten thumb screw.

## Needle Plate

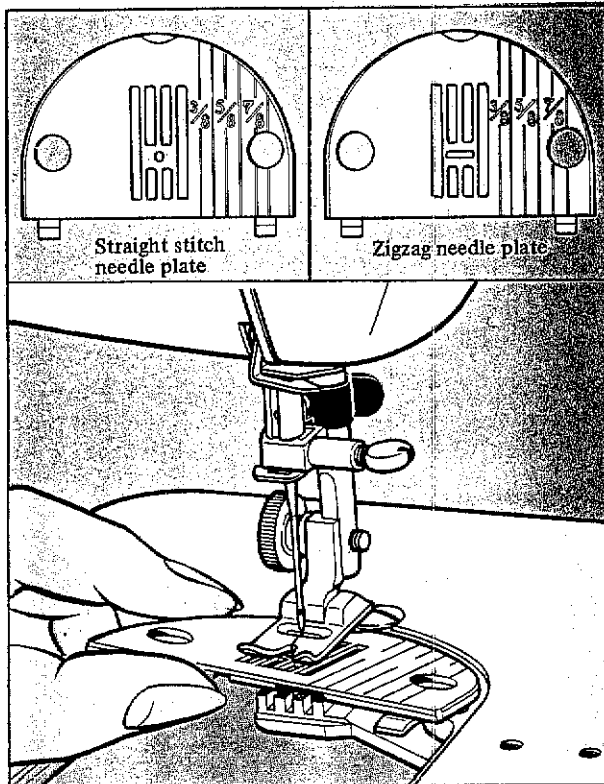

The needle plate which has the wide opening for the needle can be used for both zigzag and straight stitch sewing.

However, when you sew an extremely light material in straight stitch, we recommend that you use straight stitch needle plate which has a small hole as well as straight stitch presser foot.

We recommend that you use the guide lines on the needle plate to keep the seam straight.

For example, when you wish to sew  $\frac{3}{8}$  inch from the edge, place the edge of material on the line  $\frac{3}{8}$ .

To change needle plate;

1. Raise needle to its highest position.
2. Raise presser foot.
3. Draw slide plate out toward you and lift out the needle plate.
4. Insert groove of new needle plate under the rear needle plate screw.
5. Fit holes of needle plate to the guide screws and press it down.
6. Close slide plate.

NOTE: Do not loosen guide screws.

## Sew - Light

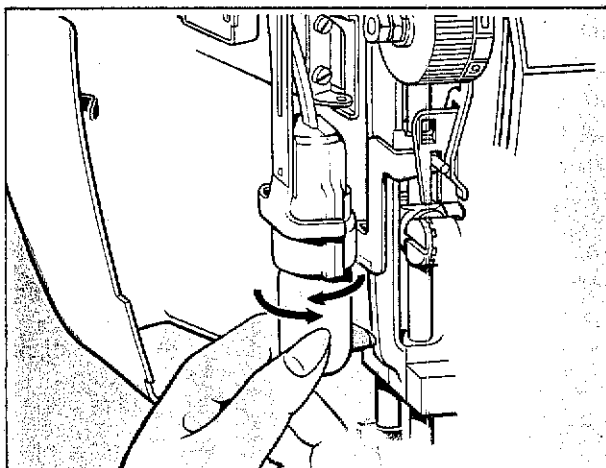

To change the bulb;

1. Open the face plate by swinging it.
2. Remove bulb by turning counter-clockwise.
3. After replacement, close the face plate...

NOTE: Make sure to switch off the light when you replace the bulb.

## Various Controls

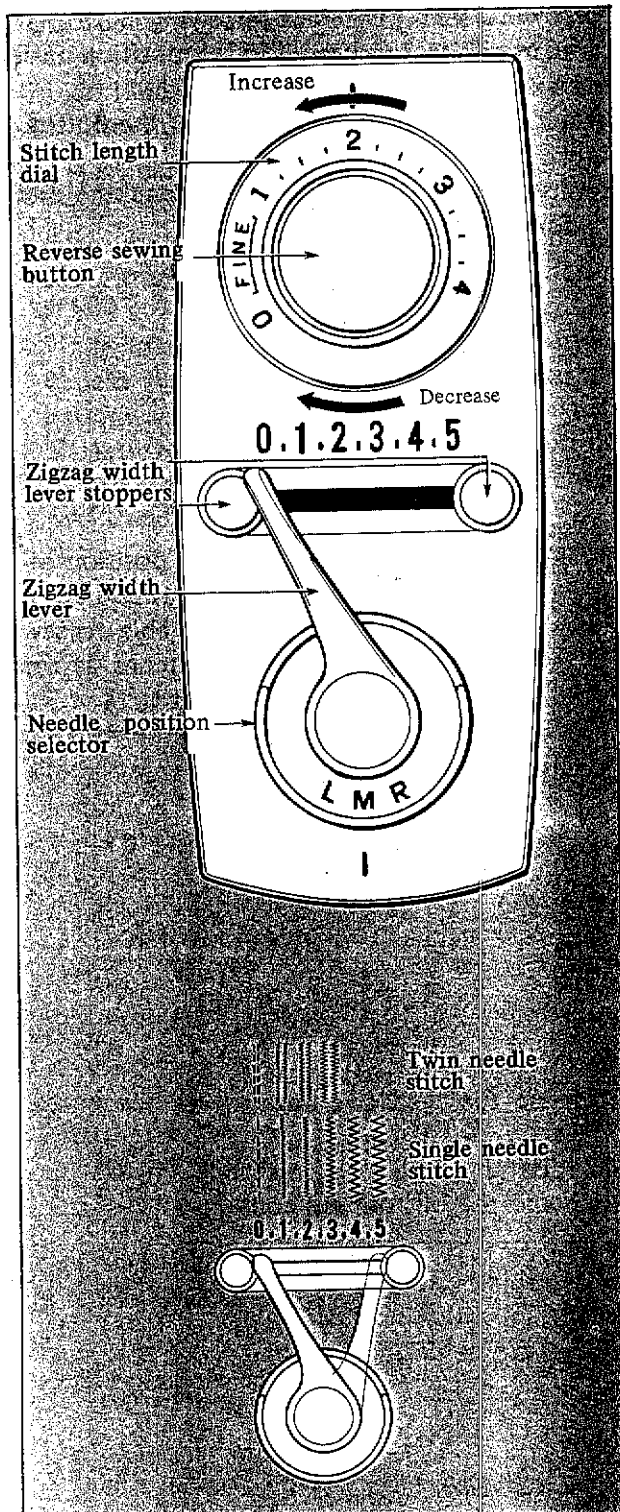

### STITCH LENGTH

The stitch length is regulated by turning the stitch length dial.

Numerals on the dial represent the stitch length. **THE HIGHER THE NUMBER, THE LONGER THE STITCH.**

The '0' means that the material is not fed. The 'FINE' area is used for making a **SATIN STITCH** (a close zigzag stitch) and this stitch is used for making buttonhole and decorative patterns.

The dial position needed to obtain the satin stitch is varied according to the material and thread being used. To determine exact dial position, you must observe the feeding of the material.

### ZIGZAG WIDTH

The zigzag width is regulated by operating the zigzag width lever.

This lever springs back to the left when you release your finger for easy operation.

Numerals above the lever represent the width of stitch. **THE HIGHER THE NUMBER, THE WIDER THE STITCH.**

The '0' means no width of zigzag, in other words, straight stitch.

**NOTE:** 1. Do not move the lever while the needle is in the material.

2. Set lever always under 3 when you use twin needle.

### ZIGZAG WIDTH LEVER STOPPERS

Zigzag width lever stoppers are used to limit the zigzag width.

Stopper "left" is used to limit the minimum zigzag width.

Stopper "right" is used to limit the maximum zigzag width.

To shift the stoppers, press and shift to desired position.

## REVERSE STITCH

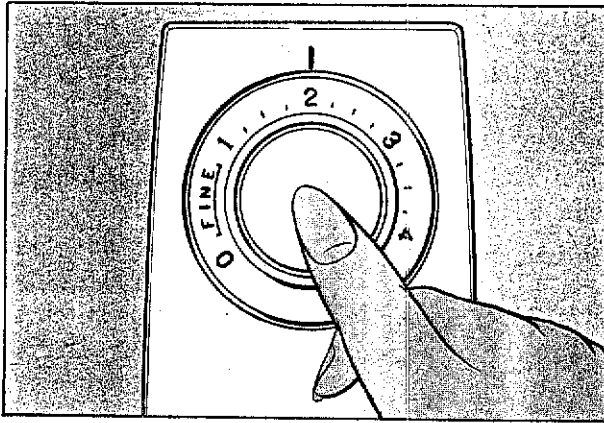

To sew reverse, push reverse sewing button as far as it will go and keep it in this position until you wish to sew forward.

When you release your finger from the button, it springs back for forward sewing.

Reverse sewing is used for back tacking and reinforcement of the seam.

## NEEDLE POSITION

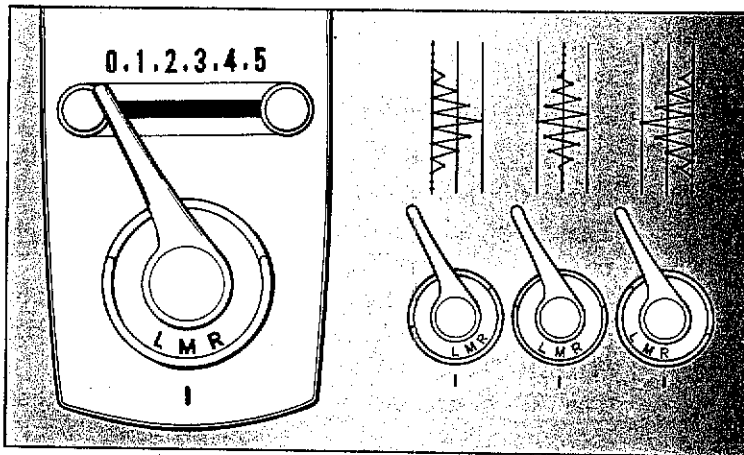

By shifting the needle position selector to L (left), M (middle) or R (right), you will be able to sew straight and zigzag stitches as the base line that you select L, M or R.

NOTE: 1. Do not move the selector while needle is in the material.

2. Set the selector always at M when you sew built-in patterns and when using twin needle.

## HEIGHT OF FEED DOG

The height of feed dog is regulated by drop feed push button at the right front of the machine bed.

To drop the feed dog down, push the button down.

To raise the feed dog, push the button once again and the button will come up.

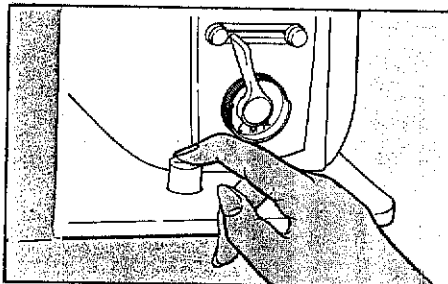

Drop feed	Height of feed dog	Sewing purpose
		Button sewing Darning, Mending, Embroidering, Monogramming
		General sewing



## PATTERN SELECTION

Your built-in pattern sewing machine has a clear-view pattern window so that you can select various kinds of utility and decorative stitches and buttonhole cams by just moving the indicator.

To select pattern cams;

1. Raise needle to its highest position.
2. Push pattern selection push button on the top cover down with your left hand as far as it will go.
3. While holding the push button in this position, choose the pattern you desire by turning the pattern selection knob with your right hand.
4. Release your left hand from the push button, and the selection knob is fixed at the cam you select and will not turn.

To select buttonhole cams;

1. Push the button down.
2. While pushing the button, move the indicator to A.
3. First release your left hand from the push button at A position while holding the selection knob with right hand.
4. Push the button down, and the indicator moves to the next steps B, C and D.

NOTE: 1. When no built-in pattern is required the indicator must be always set at M.  
2. While you push the push button, you can slide the indicator smoothly between cam No.1 and M but when the indicator is set at the buttonhole cams, A, B or C, the selection knob will not turn, even if you press the button.

In this case, push the button repeatedly until the indicator moves to D position.

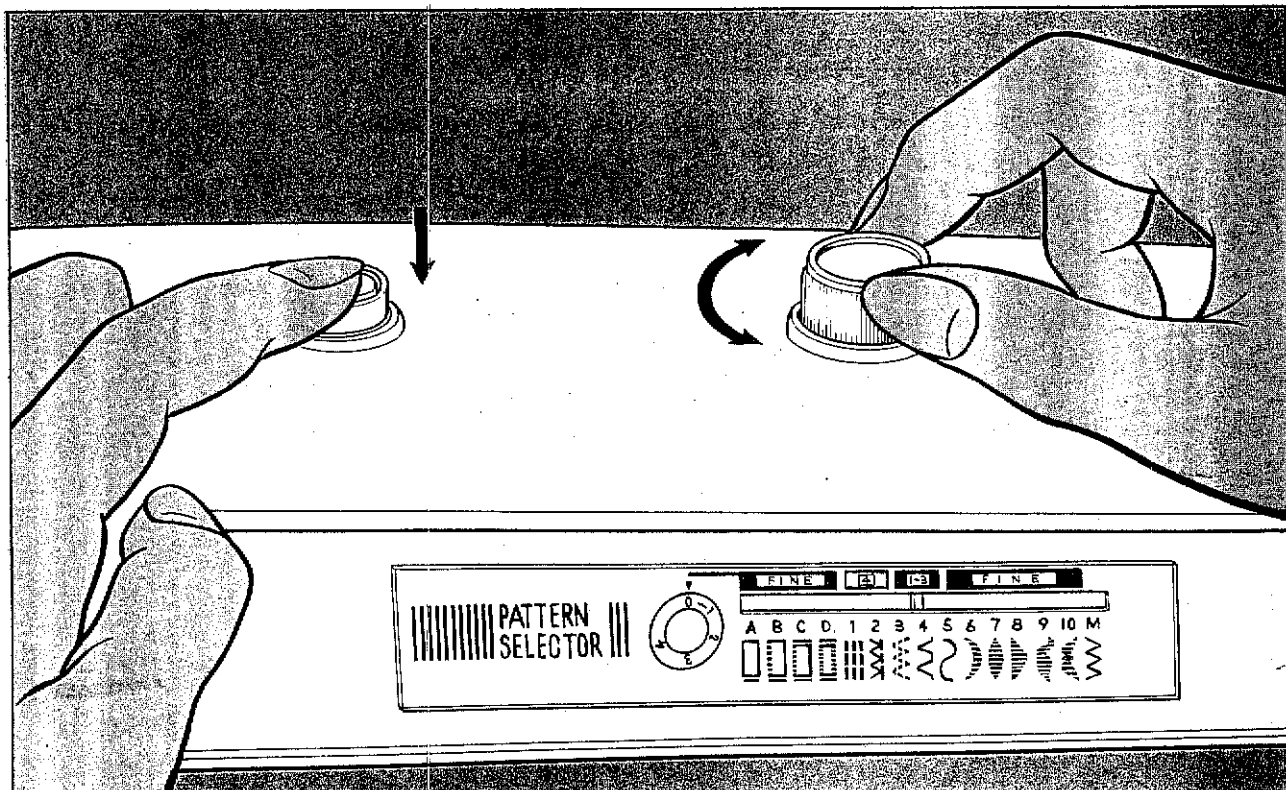

# PATTERN INDICATOR PLATE

Symbol, FINE and numerals above the indicator represent the position of stitch length dial which must be set for each pattern.

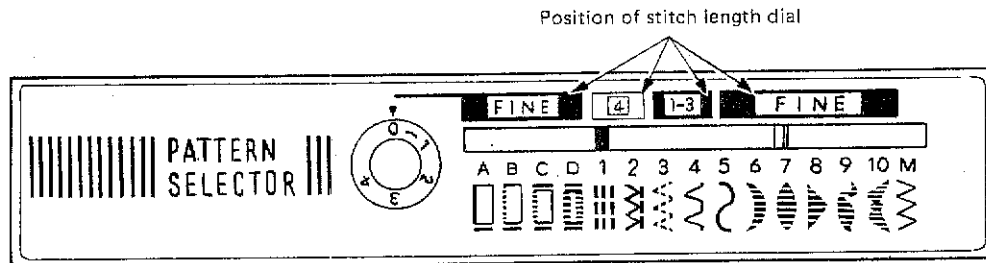

<p><b>A-D / BURTONHOLE</b></p>	<p><b>1 / TRIPLE STRETCH STITCH</b></p>	<p><b>2 / STRETCH BIND STITCH</b></p>
<p><b>3 / ELASTIC STITCH</b></p>	<p><b>4 / BLIND STITCH</b></p>	<p><b>5-10 / DECORATIVE STITCHES</b></p>
<p><b>6 / SCALLOP</b></p>	<p><b>M / STRAIGHT &amp; ZIGZAG STITCHES</b> (Appliquing, Monogramming, Embroidering, etc.)</p>	

## THREAD TENSIONS

Correct tensions on both upper and lower threads are very important and should be equal so that both threads are drawn into the center of the work without loops on the top or bottom of the work.

Make a few samples and examine whether your sample stitches are perfect before actual sewing starts.

### UPPER THREAD TENSION

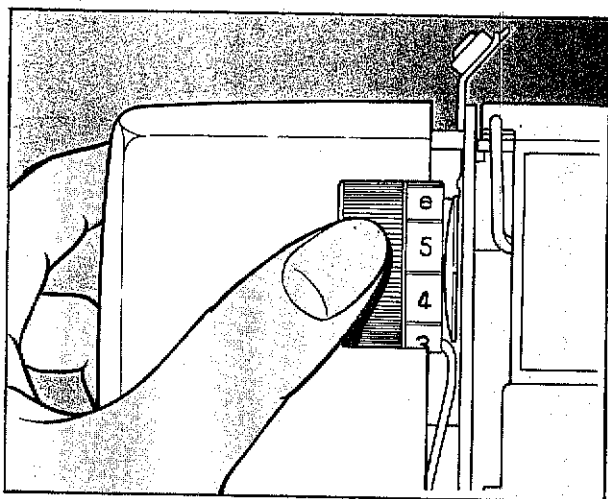

To regulate upper thread tension, merely turn thread tension dial with left thumb after lowering the presser foot.

THE HIGHER THE NUMBER, THE TIGHTER THE TENSION.

To increase tension: Turn dial downward to larger number.

To decrease tension: Turn dial upward to smaller number.

NOTE: When sewing the zigzag stitch, it requires less upper tension than straight stitch.

### LOWER THREAD TENSION

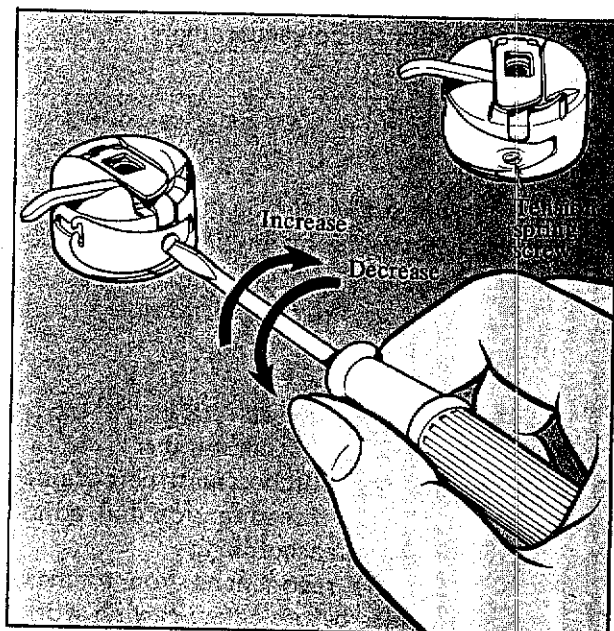

Lower thread tension has been already adjusted for general use at the factory before shipment but when sewing extremely thin or heavy material, it requires to adjust the lower thread tension also.

To regulate the lower thread tension, turn small screw on the tension spring of the bobbin case with the small screw driver.

To increase tension: Turn the small screw clockwise very slightly.

To decrease tension: Turn the screw counter-clockwise very slightly.

PERFECT STITCHING

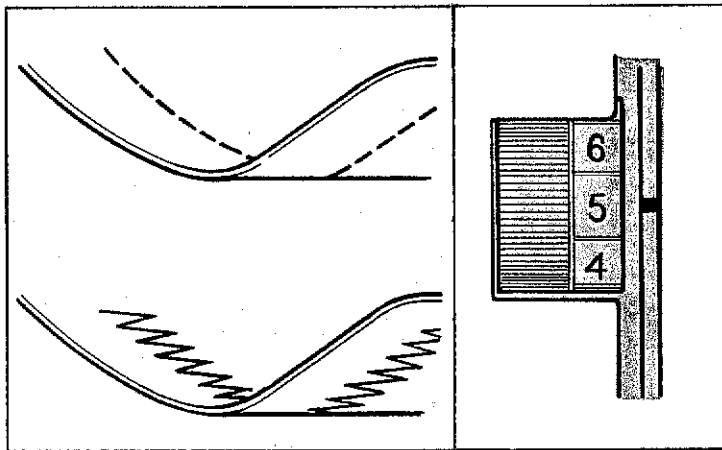

The tension of the upper and lower threads should be equal and just sufficiently strong to lock both threads in the center of the work. Perfect stitch shows flat and no puckering result on the material.

INCORRECT STITCH (A)

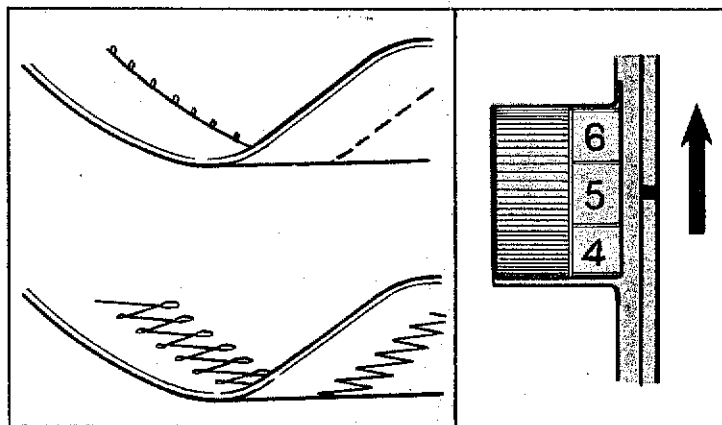





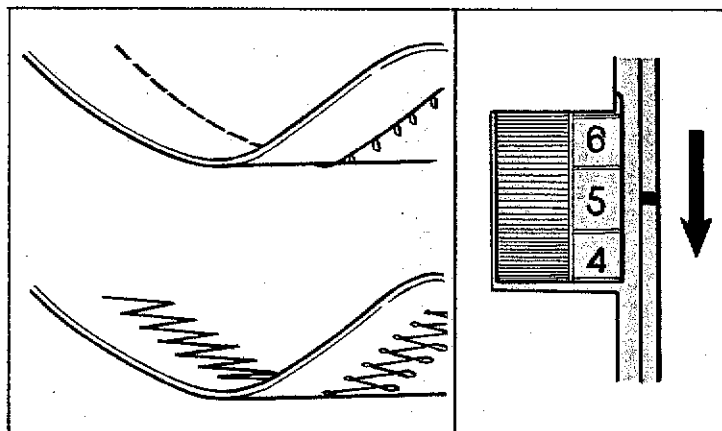

The upper thread lies on the surface of the material by pulling the lower thread up as shown. This is caused by tight tension on the upper thread or loose tension on the lower thread. To correct this, turn the upper thread tension dial to a lower number. When perfect stitch cannot be obtained by only upper thread tension dial, adjust the bobbin tension accordingly.

INCORRECT STITCH (B)

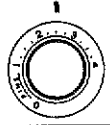

The lower thread lies on the under surface of the material by pulling upper thread down as shown. This is caused by loose tension on the upper thread or tight tension on the lower thread. To correct this, turn the upper thread tension dial to a higher number. When perfect stitch cannot be obtained by only upper thread tension dial, adjust bobbin tension accordingly. NOTE: We recommend you to make test samples before actual sewing work.

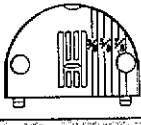
SET YOUR SEWING MACHINE AS PER FOLLOWING TABLE.

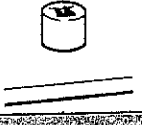
Pattern Indicator	Stitch Length	Zigzag Width	Presser Foot	Needle	Needle Plate	Needle Position	Drop Feed
							
M	1-4	0	Straight or Zigzag	Single needle	Straight or Zigzag	M	Up

NOTE: When you sew extremely light materials in straight stitch, use straight stitch foot and needle plate.

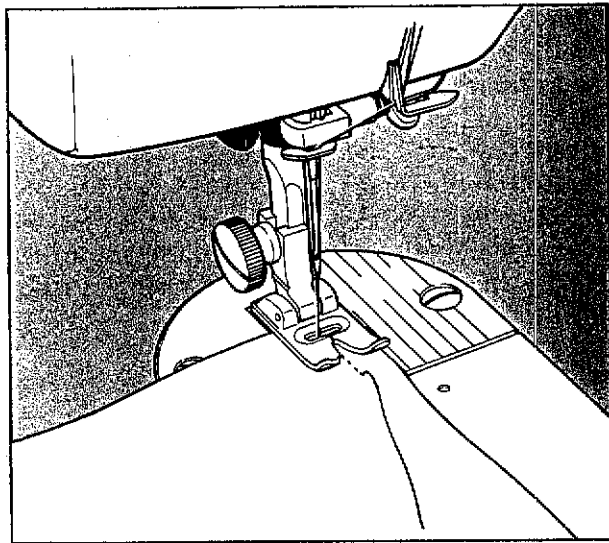

#### TO START SEWING

1. Raise needle to its highest position and lift presser foot.
2. Place material under the presser foot to position the needle about half inch from the starting point.
3. Lower presser foot.
4. Start reverse sewing by pushing the reverse sewing button to the starting point for reinforcement.
5. Release the button and make forward stitching.

NOTE: Do not pull the material. Let the machine do the work. Merely guide the material with your fingers. If you pull the material, your needle might either bend or break.

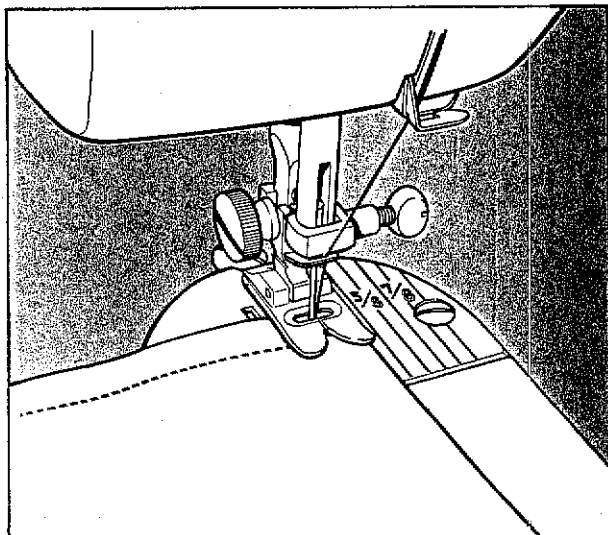

#### TO CHANGE THE SEWING DIRECTION

1. Stop machine at the turning point while the needle is in the material.
2. Raise the presser foot and turn the material to the new direction while the needle acts as the axis.
3. Lower the presser foot and start sewing to the new direction.

NOTE: In case of twin needle sewing, raise the needle at the turning point.

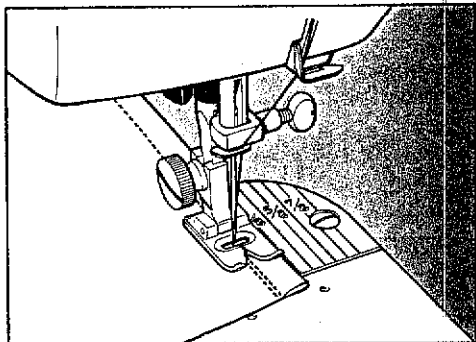

### TO FASTEN THE FINAL SEWING

1. Continue to stitch to the edge of the work and stop the machine.
2. Push the reverse sewing button and make backward stitches about half inch from the end of the stitch.

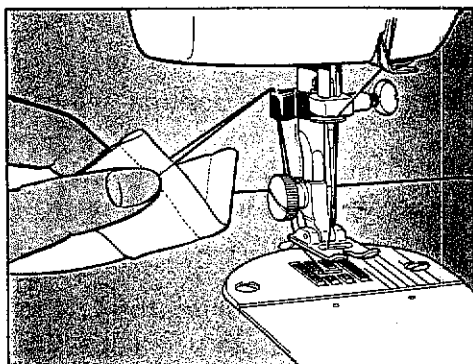

### TO REMOVE THE WORK

1. Stop the machine.
2. Raise needle to its highest position and make sure that the thread take-up lever is in the highest position also.
3. Lift presser foot and pull out the material gently to the left side diagonally.
4. Cut both threads on the thread cutter.
5. Leave 3 - 4 inches of threads between toes of the presser foot to the rear while the thread take-up lever is at the highest position, and you are ready to sew again without any chance of thread running out of needle.

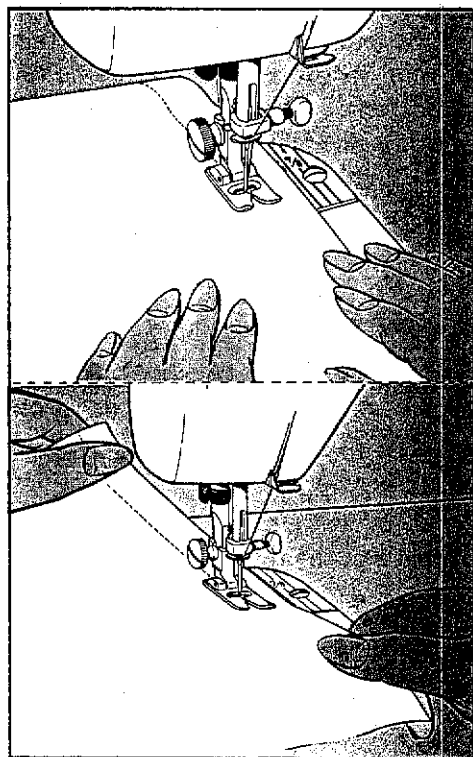





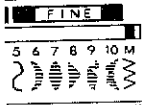
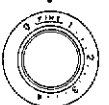

### TO GUIDE AND SUPPORT THE MATERIAL

Generally it is enough to guide the material in front of the presser foot as shown in the upper figure.

However, in case of special materials such as tricot, crepes, knits, etc., we recommend you to support the material both in front and back of the presser foot with gentle tension as shown in the lower figure.

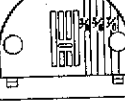
SET YOUR SEWING MACHINE AS PER FOLLOWING TABLE.

Pattern Indicator	Stitch Length	Zigzag Width	Presser Foot	Needle	Needle Plate	Needle Position	Drop Feed
							
M	FINE-4	1-5	Zigzag	Single needle	Zigzag	M	Up

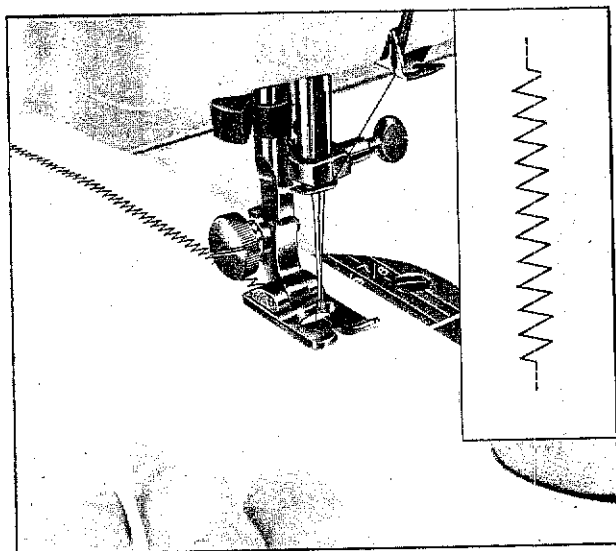

### SIMPLE ZIGZAG STITCH

When you set the stitch length dial to 1 - 4, you can obtain "SIMPLE ZIGZAG STITCH".

1. Before stitching zigzag, sew about 5 - 6 straight stitches at FINE area for reinforcement.
2. Set zigzag width lever to your desired width and commence to sew.
3. At final sewing, reset the zigzag width lever to "0" and sew about 5 - 6 straight stitches at FINE area for reinforcement.

NOTE: Generally, zigzag stitch requires less upper thread tension than the straight stitches.

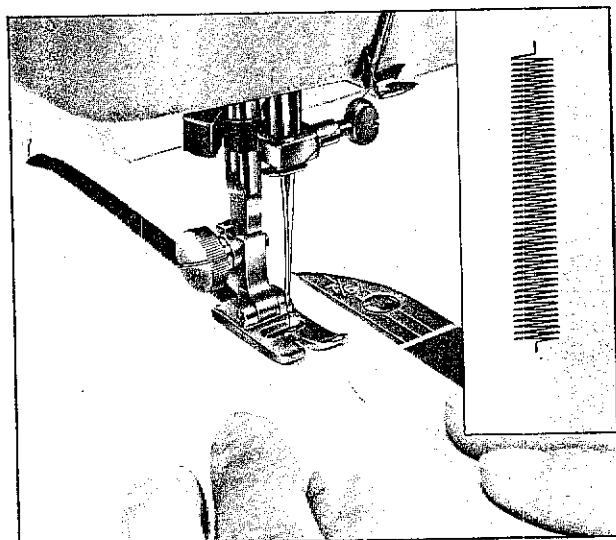

### SATIN STITCH

When the stitch length dial is set to FINE area, the machine produces the closest zigzag stitch called "SATIN STITCH" which is used for making the buttonhole and various decorative stitches.

NOTE: Position of the stitch length dial to get the SATIN STITCH is varied depending upon the size of threads and the material being used, so we suggest you to make a test sample first and determine the best FINE area.

# 4 Using Built-in Patterns

SET YOUR SEWING MACHINE AS PER FOLLOWING TABLE FOR EACH PATTERN.

	PATTERN	NAME & USAGE	STITCH LENGTH	ZIGZAG WIDTH	NEEDLE	BRESSER FOOT	NEEDLE PLATE	NOTE
A, B, C, D		Button-hole	FINE	3-5	Single	Button-hole foot	Zigzag	<p>NEEDLE POSITION</p> <p>: M</p> <p>DROP FEED</p> <p>: UP</p> <p>*1 in case of triple stretch stitch in straight, must be set to 0.</p> <p>*2 in case of twin needle, must be set to 3.</p>
1		Triple stretch stitch	4	0-5 <sup>*1</sup>	Single	Zigzag	Zigzag	
2		Stretch blind stitch	4	5	Single	Zigzag	Zigzag	
3		Elastic stitch	1-3	3-5	Single	Zigzag	Zigzag	
4		Blind stitch	1-3	3-5	Single	Zigzag	Zigzag	
5		Decoration	FINE	3-5 <sup>*2</sup>	Single & Twin	Zigzag	Zigzag	
6		Decoration (Scallop)	FINE	3-5	Single & Twin	Zigzag	Zigzag	
7		Decoration	FINE	3-5	Single & Twin	Zigzag	Zigzag	
8		Decoration	FINE	3-5	Single & Twin	Zigzag	Zigzag	
9		Decoration (Swan)	FINE	3-5	Single & Twin	Zigzag	Zigzag	
10		Decoration (Butterfly)	FINE	3-5	Single & Twin	Zigzag	Zigzag	



## BUTTONHOLES (No. A – D)

SET YOUR SEWING MACHINE AS PER FOLLOWING TABLE.

Pattern Indicator	Stitch Length	Zigzag Width	Presser Foot	Needle	Needle Plate	Needle Position	Drop Feed
A-D	FINE	3-5	Buttonhole foot	Single needle	Zigzag	M	Up

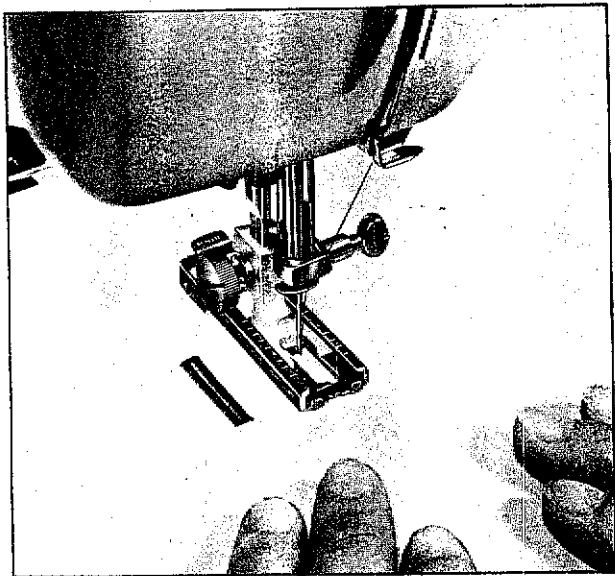

1. Use buttonhole foot with sliding portion.
2. Choose the best zigzag width (width of bar tack) between 3 to 5 to suit your work.
3. Using tailor's chalk, mark on the material.
4. Attach the buttonhole foot and push the sliding portion toward rear until it stops.
5. Place the material under the presser foot so that front end of bar tack can be sewn first.

**NOTE:** In order to make many buttonholes in same size, use the calibrations on the foot.

Also, we suggest you to make a test sample before actual sewing.

### PROCEDURE OF MAKING BUTTONHOLE

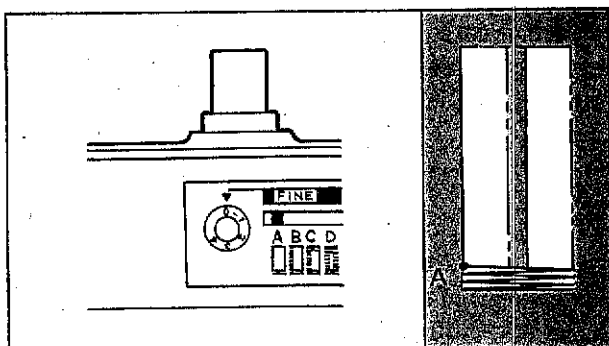

Step A: Front end of bar tack.

1. Set pattern indicator to A.
2. Lower presser foot and sew 5 to 6 stitches.
3. Stop machine when the needle is at position A and raise needle from the material.

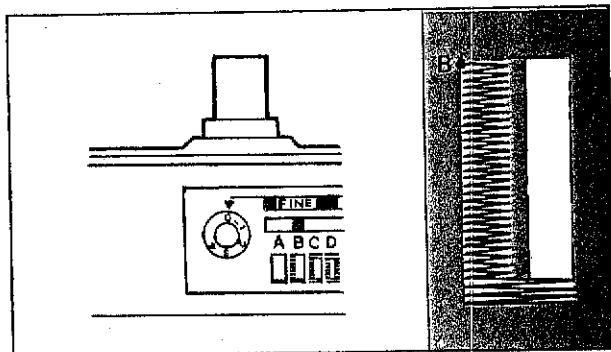

**Step B : Left side row**

1. Press the push button and check the indicator to be set at B.
2. Sew predetermined length to position B.
3. Stop machine at position B and raise the needle.

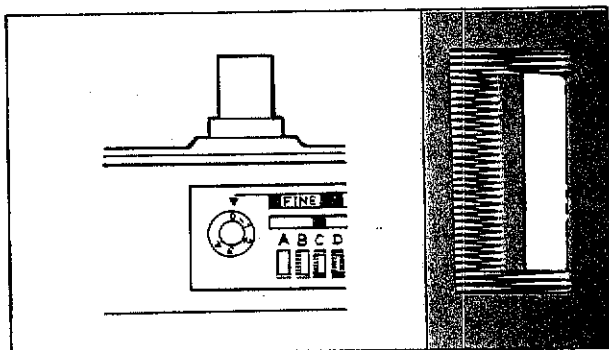

**Step C : Back end of bar tack.**

1. Press the push button and set the indicator to C.
2. Sew 5 to 6 stitches.
3. Stop machine at position C and raise the needle from the material.

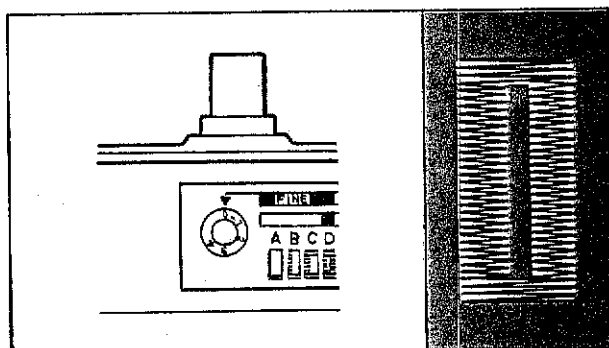

**Step D : Right side row**

1. Press the push button and set the indicator at D.
2. Sew the right side row until the needle reaches position D.
3. Raise the needle from the material.
4. Set zigzag width lever to 0 and sew 5 to 6 stitches on the row to fasten the seam.
5. Raise presser foot and remove the work.
6. Cut opening for button with seam ripper taking care not to cut stitches.



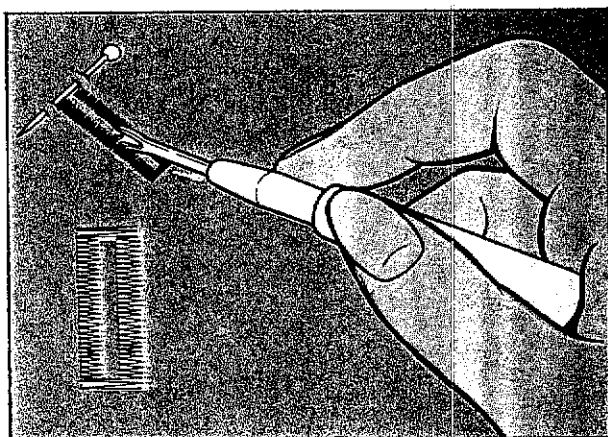

In this case, place pins across the cutting place at each end of buttonhole to protect bar tacks.

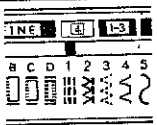
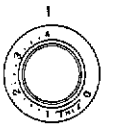
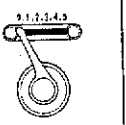

- NOTE:**
1. Do not press the push button while needle is in the material.
  2. Make sure that you press the push button into the machine as far as it will go and check the indicator to be set to the next step.

### TRIPLE STRETCH STITCH (No. 1)

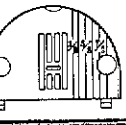
SET YOUR SEWING MACHINE AS PER FOLLOWING TABLE.

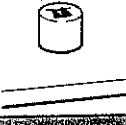
Pattern Indicator	Stitch Length	Zigzag Width	Presser-Foot	Needle	Needle-Plate	Needle Position	Drop-Feed
							
1	4	0-5	Zigzag	Single needle	Zigzag	M	Up

NOTE: If necessary, use the golden stretch stitch needle for stretch material.

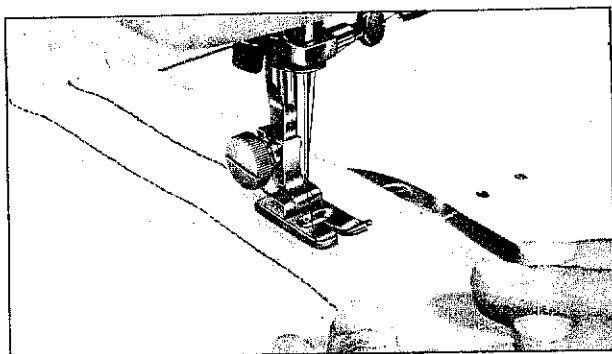



The "triple stretch stitch" is used with the stretch material such as, knitted fabric and tricot and this stitch gives three times the strength of regular lock stitch and the stretch to the seam.

So you can stretch this seam together with the stretch material with no breakage of the thread.

NOTE: When zigzag width lever is set to 5, triple zigzag stitch can be produced which is useful for decorating skirts, aprons etc. beside stretch seam.

### BLIND STITCH (No. 2 and 4)

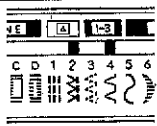
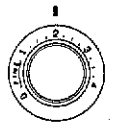
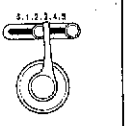
SET YOUR SEWING MACHINE AS PER FOLLOWING TABLE.

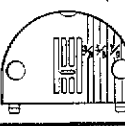
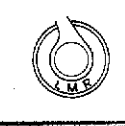
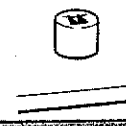
Pattern Indicator	Stitch Length	Zigzag Width	Presser-Foot	Needle	Needle-Plate	Needle Position	Drop-Feed
							
2	4	5	Zigzag	Single needle	Zigzag	M	Up
4	1-3	3-5					



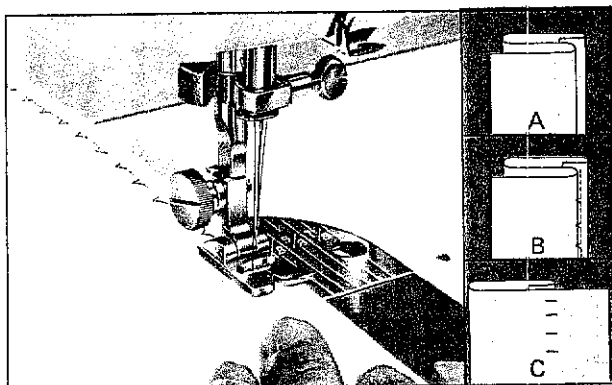

NOTE: 1. If you want stretch blind stitch, use cam No. 2. 2. Use same color threads as the material.

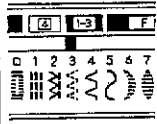
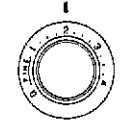
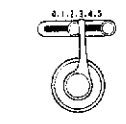

1. Fold the material into the size of the hem desired and fold back as shown in Fig. A with 1/4 inch overlapping on the bottom fold of the edge.
2. Start to sew on the fold, making the straight stitches sew on the hem edge and sideward zigzag stitches slightly touch the folded top. (Fig. B)
3. After finish, unfold the material, and you will have a blind stitch hem. (Fig. C)

## ELASTIC STITCH (THREE STEP STITCH) (No.3)

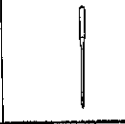
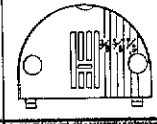
SET YOUR SEWING MACHINE AS PER FOLLOWING TABLE.

Pattern Indicator	Stitch Length	Zigzag Width	Presser Foot	Needle	Needle Plate	Needle Position	Presser Foot
							
3	1-3	3-5	Zigzag	Single needle	Zigzag	M	Up

The elastic stitch is one of the most useful stitches among various patterns of this machine and can be used for various sewing works, such as repairing tears, fitting the elastic, patching and so on.

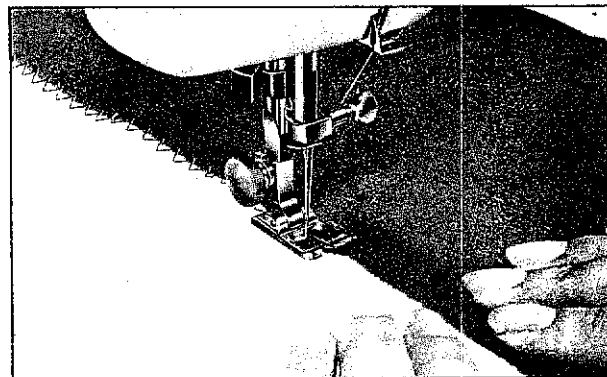
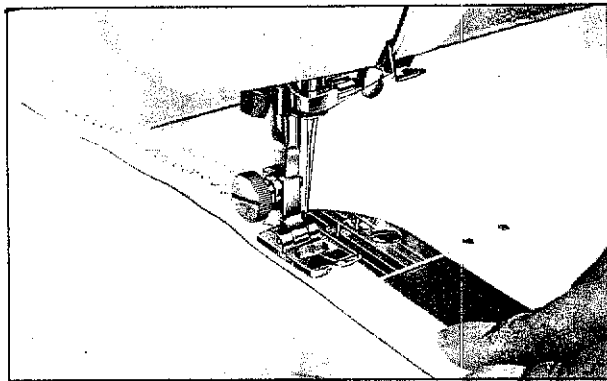
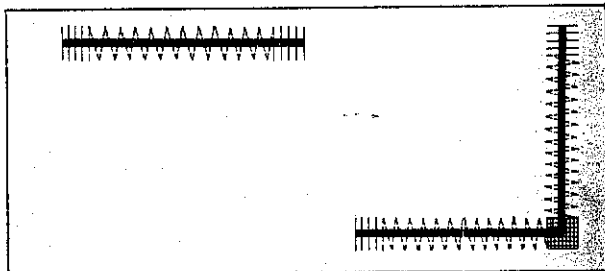

### MENDING

1. Place an underlay to the wrong side of the tear for reinforcement.
2. Following the line of tear, sew elastic stitch so that both sides of tear are joined.
3. Shorten stitch length at ends or corners by setting the dial to "FINE" area.

### FITTING THE ELASTIC

1. Place the elastic on the material.
2. Sew elastic stitch by stretching the elastic both in front and back of the presser foot.

### JOINING STITCH

When you wish to join two materials at the top of each edge, use this elastic stitch.

1. Place two materials edge to edge under the presser foot.
2. Sew elastic stitch, paying careful attention not to separate each edge.

NOTE: This stitch is also very useful as for fagoting stitch.







### SEWING ON KNITS

Knitted garments are sewn by this elastic stitch effectively.

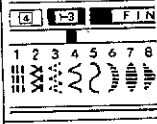
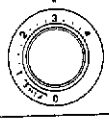
1. Use nylon thread, and stitch will be invisible.

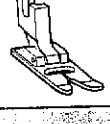
### SHELL STITCH (No. 4)

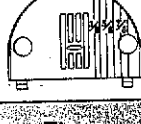
SET YOUR SEWING MACHINE AS PER FOLLOWING TABLE.

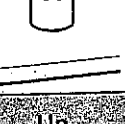
Pattern Indicator	Stitch Length	Zigzag Width	Presser Foot	Needle	Needle Plate	Needle Position	Drop Feed
							
4	3	5	Zigzag	Single needle	Zigzag	M	Up

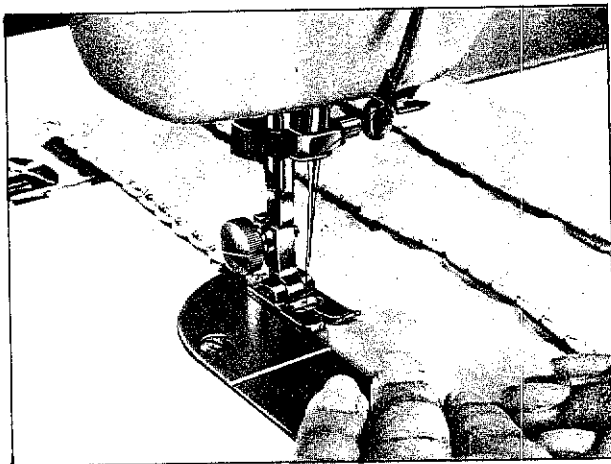





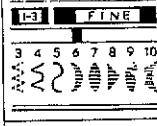

This stitch is especially useful for finishing the edge of light material.

1. Set the machine as for blind stitch.
2. Place the material under the presser foot so that straight stitches sew on the seam line and zigzag stitches sew slightly over the seam edge.
3. This work requires a little tighter upper thread tension than normal.
4. Sew stitches carefully.
5. Now you have the shell stitch, edge of seam comes picotted.

### SCALLOPING (No. 6)

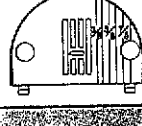
SET YOUR SEWING MACHINE AS PER FOLLOWING TABLE.

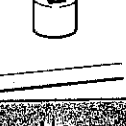
Pattern Indicator	Stitch Length	Zigzag Width	Presser Foot	Needle	Needle Plate	Needle Position	Drop Feed
							
6	FINE	5	Zigzag	Single needle	Zigzag	M	Up

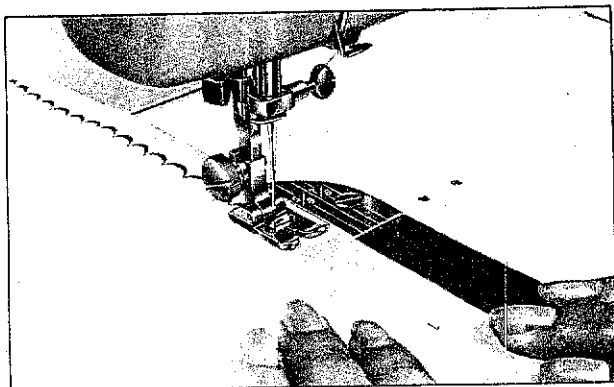

The "scalloping" stitch makes the collar, cuff, the sleeve of a blouse, the edge of the table cloth and so on very attractive, and also it is effective as a trimmer.

1. Sew the scallop along the edge of the material.
2. Trim excess portion along scalloped edge with a scissors.

## BUTTON FITTING

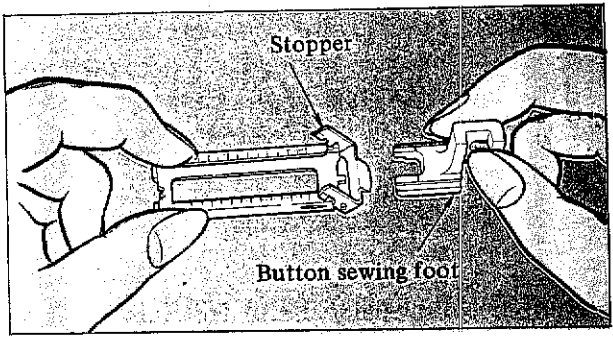

Removing the sliding portion of buttonhole foot, you will have a button sewing foot. To remove the sliding portion, push the stopper down and slide the button sewing foot backward.

SET YOUR SEWING MACHINE AS PER FOLLOWING TABLE.

Pattern Indicator	Stitch Length	Zigzag Width	Presser Foot	Needle	Needle Plate	Needle Position	Drop Feed
M		Depending on the distance of holes	Button sewing foot	Single needle	Zigzag	L	Down

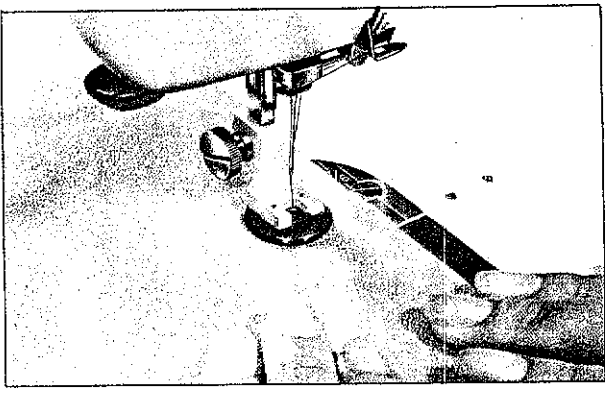

1. Place button between the presser foot and the material, making sure that holes of button fall in line with the base line of button sewing foot.
2. Control zigzag width to suit the distance of the holes of button.
3. Lower the presser foot and examine that the needle enters into both holes of button without any obstruction.
4. Slowly sew about 10 stitches.
5. Stop machine and raise needle from the material.
6. Turn zigzag width lever to "0".
7. Sew about three stitches to fasten the stitch.
8. Remove your work and cut excess threads.

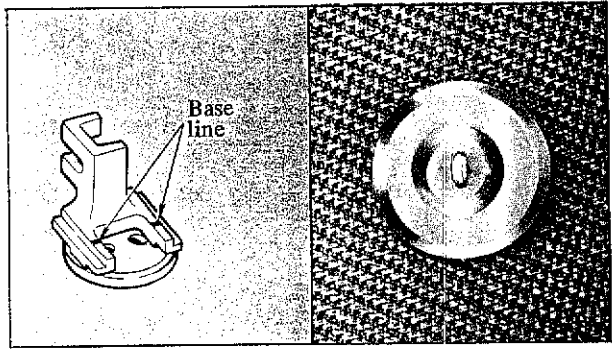

## BUTTON FITTING WITH THREAD SHANK

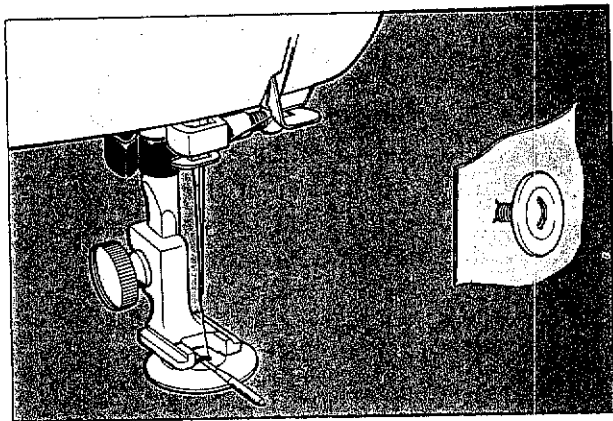

You will often need the thread shank of button for heavier materials.

1. Place a needle on the button as illustrated and sew as regular method of button fitting.
2. After about 10 stitches, remove the fabric from the machine, leaving upper thread little longer in order to form a thread shank.
3. Pull upper thread between the button and the material through the hole of button and wind upper thread tightly around the stitches.
4. Fasten the thread ends.

## NARROW HEMMING

By using narrow hemmer foot, you can make folded hem stitch which is very useful for the edge of the work.

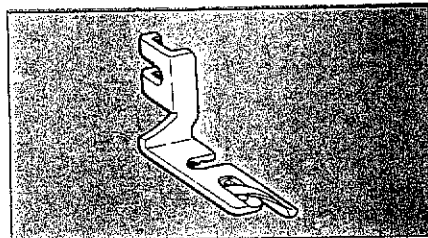

SET YOUR SEWING MACHINE AS PER FOLLOWING TABLE.

Pattern Indicator	Stitch Length	Zigzag Width	Presser Foot	Needle	Needle Plate	Needle Position	Drop Feed
M	2-3	0	Narrow hemmer foot	Single needle	Zigzag	M	Up

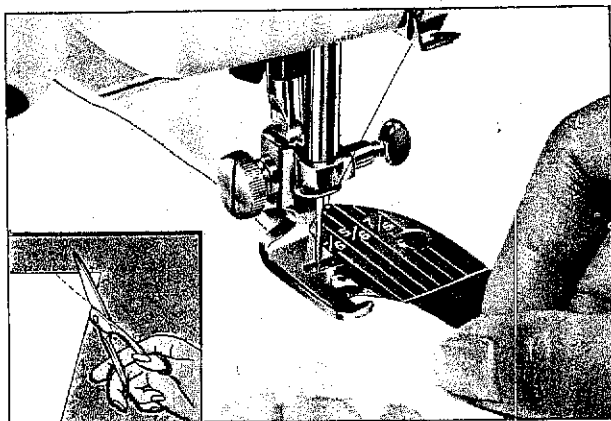

1. Cut top corner of the material about 1/8".
2. Put material wrong side up and insert cut off angle into the opening of the foot.
3. Pull out material until the needle touches and lower presser foot.
4. Start to sew gently by pulling both threads backward.
5. Continue to sew with medium speed by guiding the material, so that the edge of the roll of material is fed into the scroll opening of the foot.

NOTE: Zigzag narrow hemming can be done in the same manner, however set zigzag width under 3.

## ZIPPER INSERTION

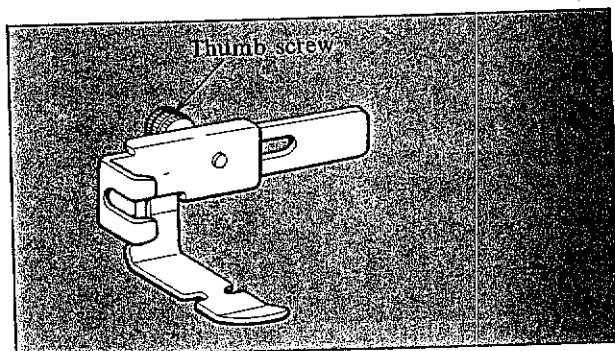

Use zipper foot to sew various kinds of zipper. It can be adjusted to either the right or left side of the needle.

When the zipper is to the right of the needle, slide the foot to the left of the needle by loosening the thumb screw located at the back.

When the zipper is to the left side of the needle, slide the foot to the right of the needle.

SET YOUR SEWING MACHINE AS PER FOLLOWING TABLE.

Pattern Indicator	Stitch Length	Zigzag Width	Presser Foot	Needle	Needle Plate	Needle Position	Drop Feed
M	2-3	0	Zipper foot	Single needle	Zigzag	V	U

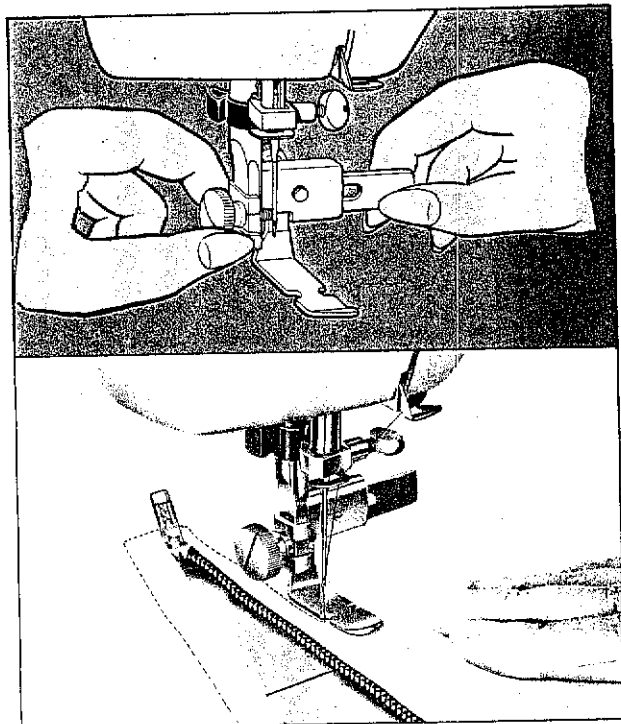

1. Lower needle into the side notch of the foot and check position of the foot to avoid needle striking the foot.
2. Fasten thumb screw to lock the foot into position.
3. Fold edge of the material by about 3/4" and place zipper under the folded portion of the material where you wish to attach the zipper.
4. Stitch close to the edge of the zipper by guiding the side of the zipper foot along the zipper teeth.
5. To sew on the opposite side of the zipper, loosen thumb screw and slide the foot in the same way.



## DARNING

SET YOUR SEWING MACHINE AS PER FOLLOWING TABLE.

Pattern Indicator	Stitch Length	Zigzag Width	Presser Foot	Needle	Needle Plate	Needle Position	Drop Feed
M		0	Darning foot	single needle	zigzag	M	Down

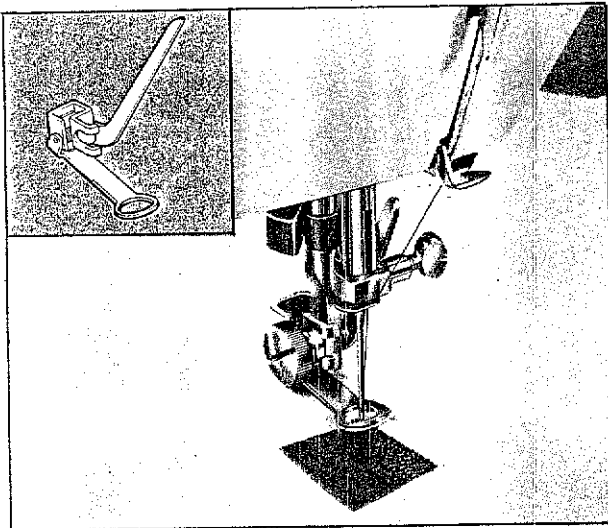

To attach the darning foot on the presser bar, make sure that the lever portion of foot comes to the needle clamp screw from the back.

1. Place portion to be darned under the presser foot.
2. Lower presser foot.
3. Sew alternately drawing the work gently away from you and pulling it toward you.
4. Repeat this motion until the portion to be darned is filled with parallel lines of stitching.

## USING CLOTH GUIDE

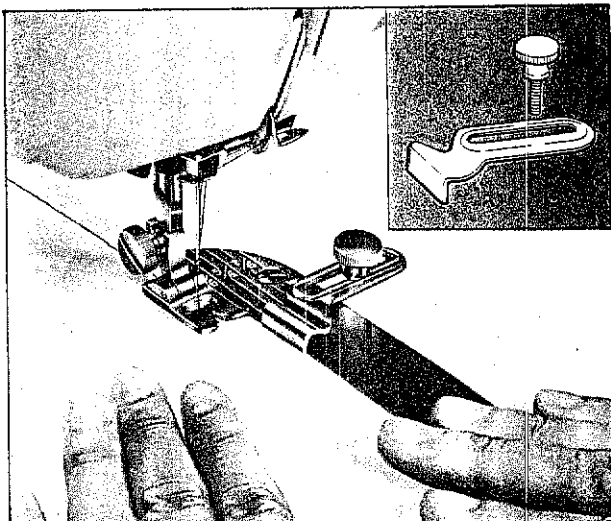





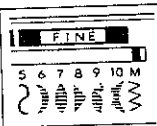
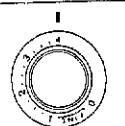

The cloth guide helps to make straight and parallel stitches follow the edge of the material. To attach the cloth guide, place it over two holes to the right of the needle plate in the sewing machine bed.

Place thumb screw through the guide slot, adjusting the guide for the desired distance and fasten it securely.

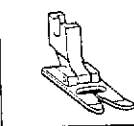
## GATHERING

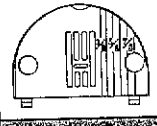
SET YOUR SEWING MACHINE AS PER FOLLOWING TABLE.

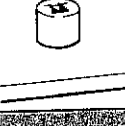

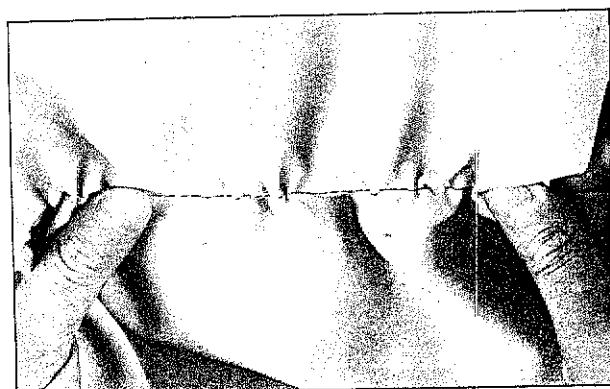

Pattern Indicator	Stitch Length	Zigzag Width	Presser-Foot	Needle	Needle Plate	Needle Position	Drop Feed
							
M	4	0	Zigzag	Single needle	Zigzag	M	Up

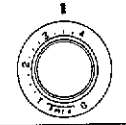
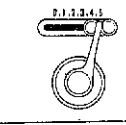
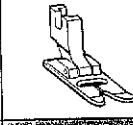

1. Loosen upper thread tension (about 2) so that lower thread lies on the under side of the material.
2. Make single or multiple rows of straight stitches.
3. After completion of sewing, pull lower thread to make gathers.

## OVERLOCK

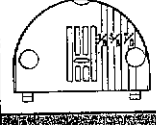
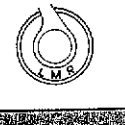
SET YOUR SEWING MACHINE AS PER FOLLOWING TABLE.

Pattern Indicator	Stitch Length	Zigzag Width	Presser-Foot	Needle	Needle Plate	Needle Position	Drop Feed
							
M	3-4	5	Zigzag	Single needle	Zigzag	M	Up

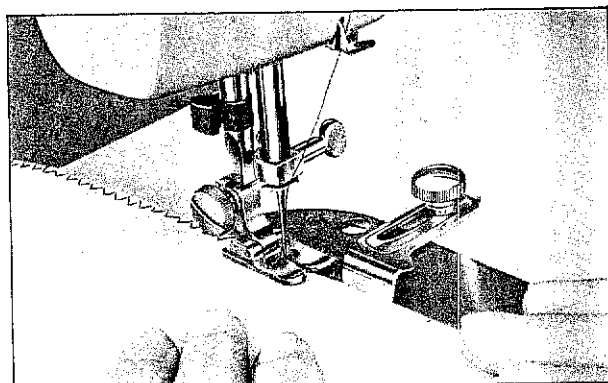

The overlock stitch is used to avoid the fraying the edge of material.

1. Place edge of the material under presser foot so that the needle sews material with its left side of zigzag stitch and just misses the edge of material with its right side of zigzag.

NOTE: It is advisable to use the cloth guide as shown.

## APPLIQUEING

SET YOUR SEWING MACHINE AS PER FOLLOWING TABLE.

Pattern Indicator	Stitch Length	Zigzag Width	Presser Foot	Needle	Needle Plate	Needle Position	Drop Feed
M	FINE-1	1-3	Zigzag	Single needle	Zigzag	M	Up

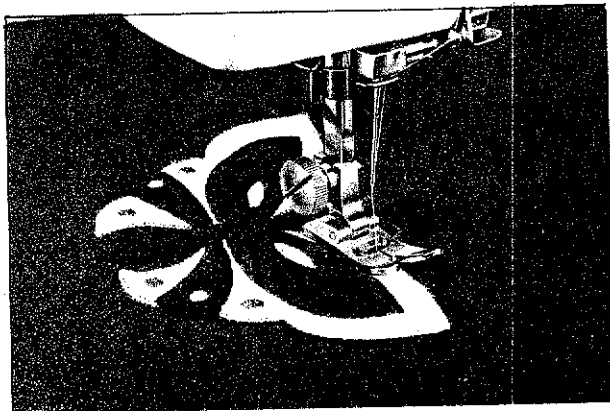

1. Baste cut design to the material.
2. Following the design, commence to sew carefully.
3. Cut away the surplus material close to the design.
4. Remove basting.

## CORDING





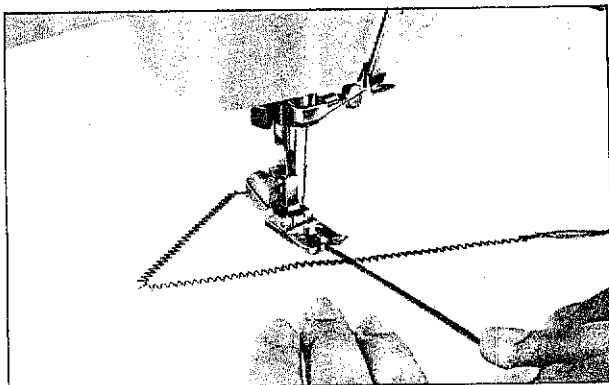

SET YOUR SEWING MACHINE AS PER FOLLOWING TABLE.

Pattern Indicator	Stitch Length	Zigzag Width	Presser Foot	Needle	Needle Plate	Needle Position	Drop Feed
M	FINE-1	1-3	Zigzag	Single needle	Zigzag	M	Up

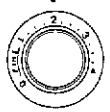

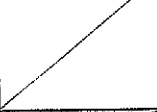
1. Set zigzag width lever according to the width of the zigzag required and the thickness of the cord being used.
2. Place the cord on the fabric so that the cord will be placed just in the center of the presser foot.
3. Lower presser foot and commence to sew zigzag stitch over the cord, by guiding the cord to your work.

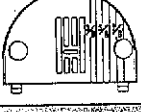
**MONOGRAMMING, USING EMBROIDERING HOOP**  
**SET YOUR SEWING MACHINE AS PER FOLLOWING TABLE.**



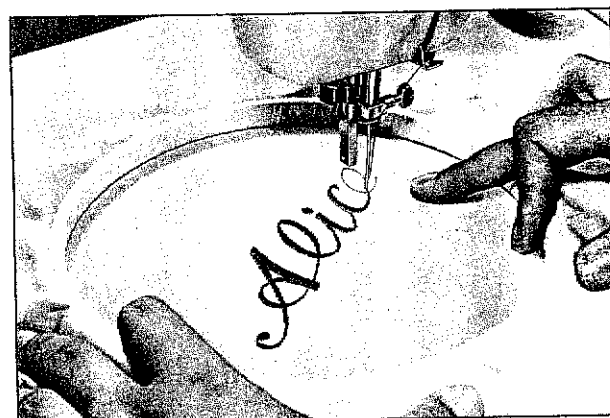
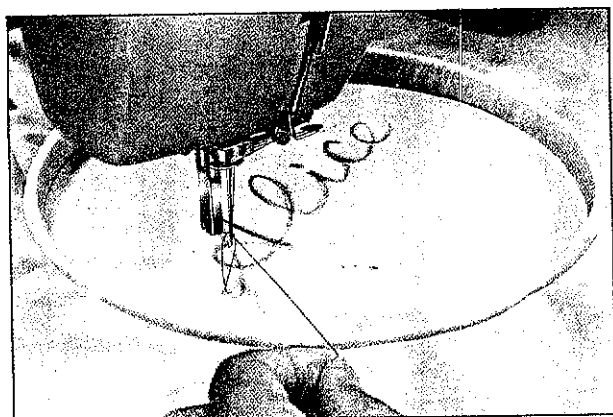

Pattern Indicator	Stitch Length	Zigzag Width	Presser Foot	Needle	Needle Plate	Needle Position	Drop Feed
							
M		0-5		Single needle	Zigzag	M	Down

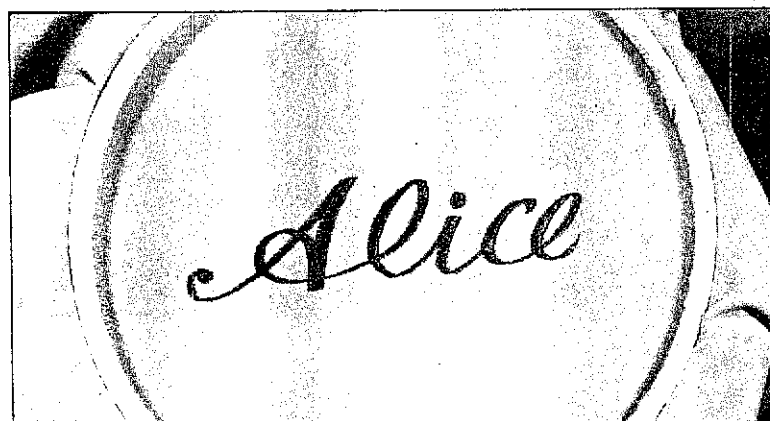

1. Remove presser foot.
2. Draw lettering on the right side of the material.
3. Stretch work between embroidering hoops as firmly as possible.
4. Place the work under the needle and lower presser bar.
5. Pull lower thread up through the work at starting position by turning balance wheel and hold both threads.
6. Hold the hoop with thumb and forefinger of both hands while pressing the material with middle and third fingers and supporting the outside of hoop with smaller finger.
7. Start sewing, moving hoop lightly along the lettering with even rate of speed while controlling zigzag width lever with your right hand.

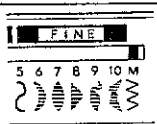
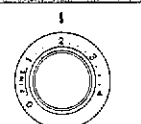
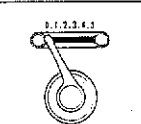
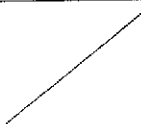

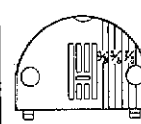
**EMBROIDERING, USING EMBROIDERING HOOP**  
 SET YOUR SEWING MACHINE AS PER FOLLOWING TABLE.

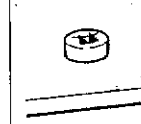
Pattern Indicator	Stitch Length	Zigzag Width	Presser Foot	Needle	Needle Plate	Needle Position	Drop Feed
							
M		0-5		Single needle	Zigzag	M	Down

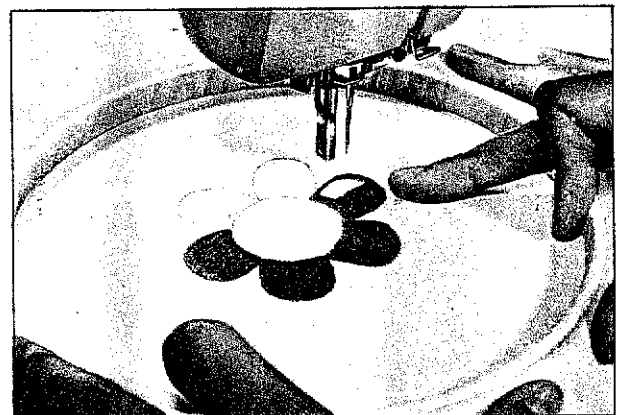
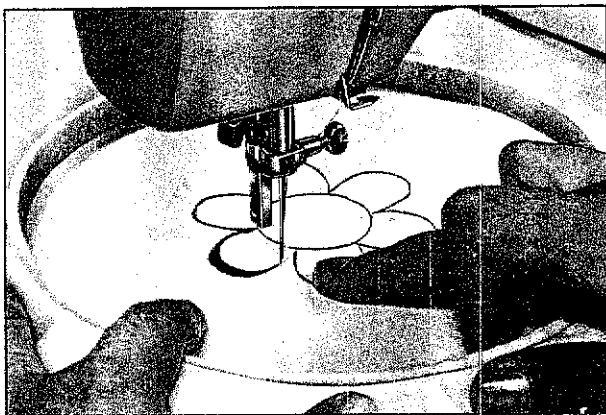

1. Remove presser foot.
2. Draw design on the material.
3. Place cloth on the embroidering hoop in the same manner as monogramming.
4. Position the hoop under the needle and lower presser bar.
5. Pull lower thread up through the work.

6. At fixed width, move embroidering hoop according to the outline of the design.
7. After the stitching of outline, sew from outside to inside and from inside to outside alternately until the area is stitched closely without leaving any space.

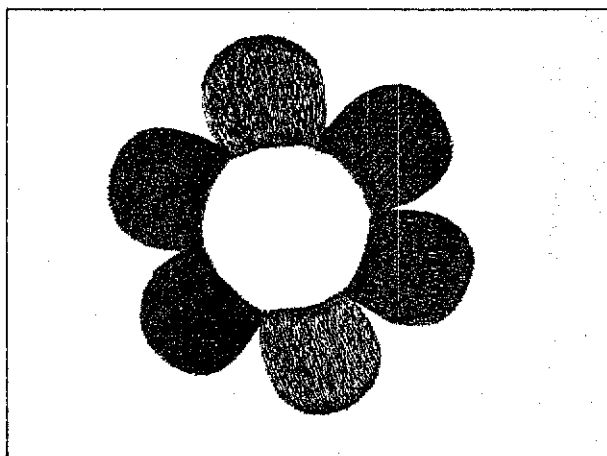

**NOTE:** To make a long stitch, move the hoop rapidly and to make a short stitch, move it slowly.

## Cleaning

The sliding parts of the shuttle race body and the hook must be cleaned regularly so that lint does not accumulate.

### TAKING OUT THE HOOK

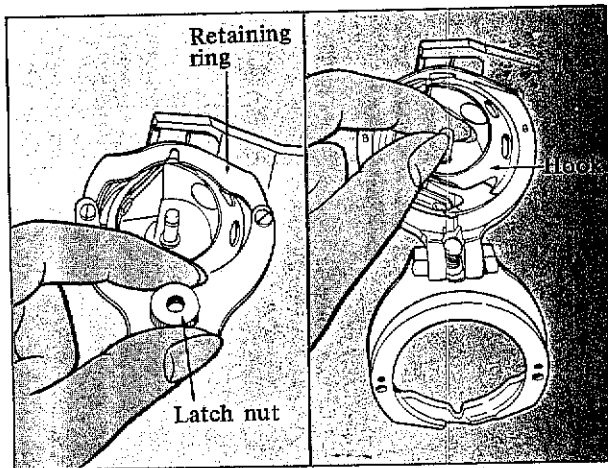

1. Raise needle to its highest position.
  2. Raise the machine head away from you.
  3. Take out bobbin case.
  4. Turn latch nut to the left.
  5. Loosen spring and open the retaining ring.  
(The retaining ring will open without taking off the latch nut)
  6. Remove hook by grasping center post of hook.
- NOTE: When needle is lowered down, the hook cannot be taken out.

### CLEANING OF SHUTTLE RACE

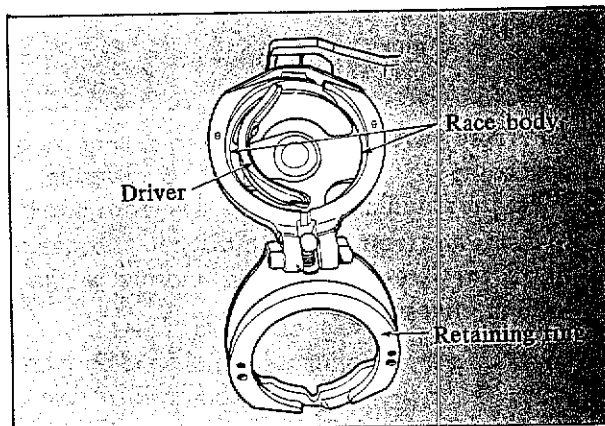

1. Remove accumulated lint and thread from the retaining ring, hook, driver and race body with brush.
  2. Wipe them cleanly with cloth imbued slightly with machine oil.
  3. The hook, too, may be cleaned in the same way.
- For assembling the parts, follow the same order in reverse.

### CLEANING OF FEED DOG

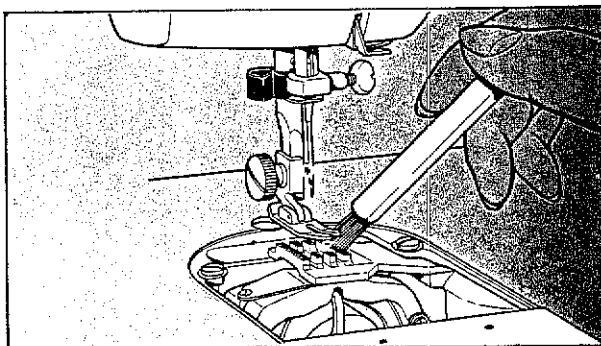

1. Take out needle plate.
2. Clean upper part of feed dog and shuttle race body with brush.

NOTE: When cleaning plastic motor and belt covers, use a neutral detergent (non acid or non alkaline substance) with a soft cloth.

## Oiling

Oiling for the moving part of the machine is the key to keep the smooth and silent operation. Apply machine oil carefully to all of the various oiling points shown in this page. After oiling, run the machine fast without thread and with the presser foot up and wipe off the excess oil completely with a scrap material in order to avoid oil stain.

OIL ONCE A WEEK, IF THE MACHINE IS USED FOR ONE HOUR A DAY.  
OIL EVERY DAY, IF THE MACHINE IS USED FOR MANY HOURS A DAY.

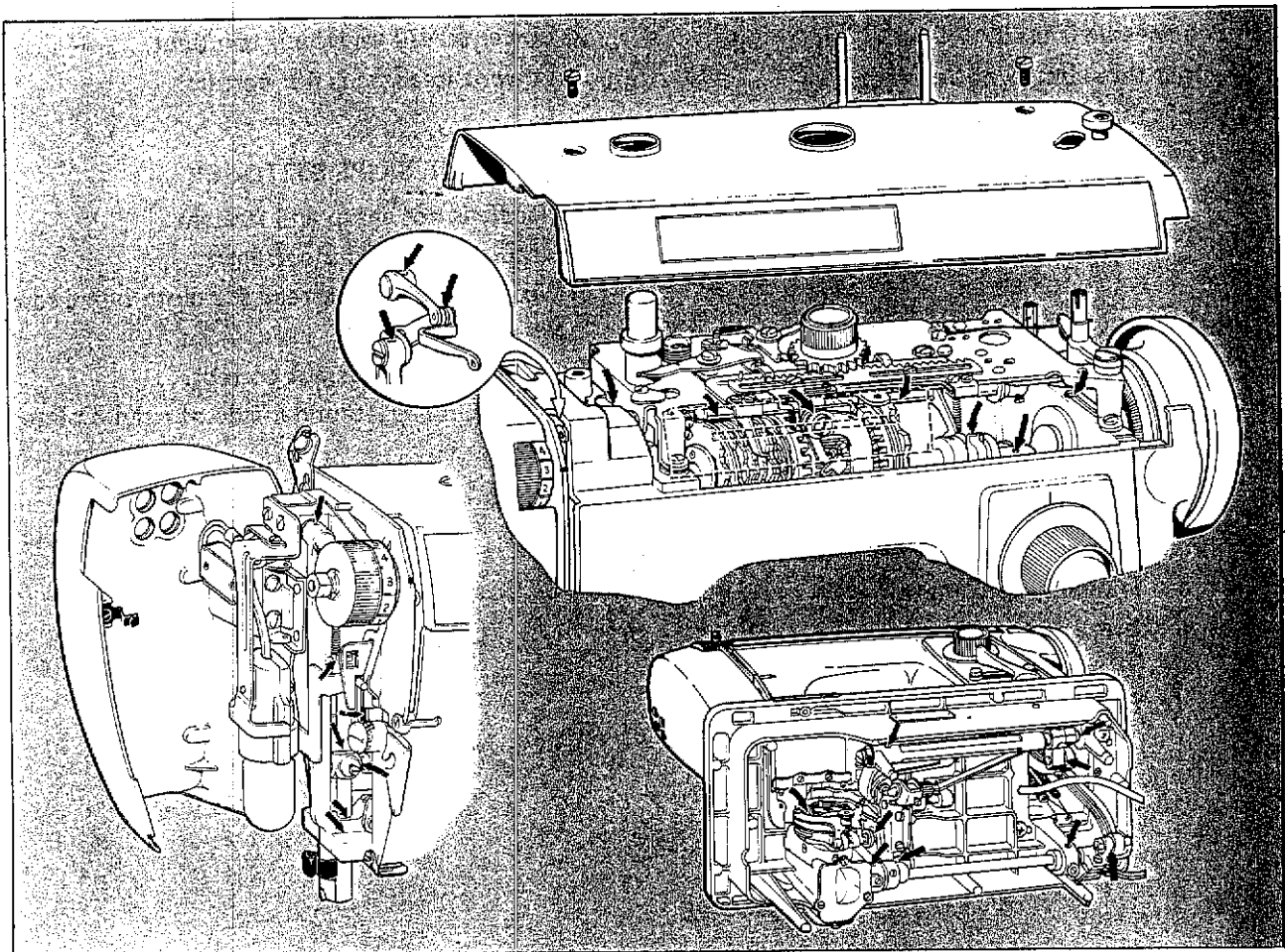

- NOTE:
1. If the machine is not used for a long time, oil will coagulate and the rotation of the machine becomes heavy. Apply a small amount of benzine to oiling points and run the machine for a few minutes. Then, wipe the machine cleanly and oil to oiling points.
  2. Over oiling of motor is not recommended. One or two drops twice a year will suffice.

## Check List for Better Sewing

### IF MATERIAL IS NOT FED

1. Feed dog is down.
2. Needle plate is out of position.
3. Stop motion knob is loose.
4. Stitch length regulator is at 0.

### IF NEEDLE BREAKS

1. Needle is inserted incorrectly.
2. Needle clamp screw is loose.
3. Bent needle is used.
4. Upper threading is not correct.
5. Upper thread tension is too tight.
6. Wrong needle and thread for cloth being sewn are used.
7. Material pulled excessively.

### IF LOOPS FORM ON FABRIC

1. Tension of upper or lower thread is wrong.

### IF MATERIAL BECOMES CREASY

1. Thread tension is too tight.
2. Threading is not correct.
3. Thread is caught by something.
4. Lower thread is unevenly wound on bobbin.

### IF UPPER THREAD BREAKS

1. Upper threading is not correct.
2. Needle eye is not sharp.
3. Upper thread is too large for needle eye.
4. Upper thread tension is too tight.
5. Needle is inserted incorrectly.

### IF LOWER THREAD BREAKS

1. Lower thread is entangled in shuttle.
2. Lower thread tension is too tight.
3. Lower threading is not correct.

### IF MACHINE SKIPS STITCHES

1. Needle is not sharp and straight.
2. Needle is inserted incorrectly.
3. Wrong needle and thread for cloth being sewn are used.
4. Upper threading is not correct.
5. Lint is clinging to under-side of needle plate.



# NOTE

A series of horizontal dashed lines for writing notes, spanning the width of the page below the 'NOTE' header.

# NOTE

A series of horizontal dashed lines for writing notes.