

Service Manual
for Sewing Machine

Free Arm Classes 21, 19, 8
Flat Bed Classes 51, 49, 71, 7



HUSQVARNA VAPENFABRIKS

AKTIEBOLAG

HUSKVARNA SWEDEN

How to remedy some of the most common sewing machine troubles.

Machine running roughly or slow:

1. Cause may be lubrication, etc. (see instruction manual).
2. Drive belt may be too tight (visual inspection).
3. Thrust collar too tight against upper arm end bearing (paragraph 1).
4. Improper mesh of gears (paragraph 2).
5. Thread caught in various gears (visual inspection).
6. Reduction gear not running freely (paragraph 23).
7. Slide block (6, Fig. 4) set too closely to feed fork thereby pushing it against eccentric (5, Fig. 4).
8. Lint between rows of teeth on feed dog (clean out).

Machine not feeding properly:

1. Make sure stitch length control is not set at 0.
2. Feed dog may be lowered. Mark on drop feed knob should be uppermost on class 21. On 51, 71 and 7 the drop feed dog should be turned so that the stitch symbol is in front.
3. Insufficient pressure on presser foot. Increase pressure by turning the regulating screw to the right (9, Fig. 10).
4. Needle in cloth as feeder is moving cloth (paragraph 6).
5. Needle moving sideways (zig zag) while in the cloth (paragraph 4).
6. Presser bar too high and not resting on material when in lowered position (paragraph 17).
7. Feed dog set too low (paragraph 9).

Needles breaking:

1. Improper size needle being used for cloth sewn.
2. Improper length needle being used.
3. Needle not inserted correctly.
4. Poor quality needle being used.
5. Operator pulling cloth.
6. Feed timing wrong (paragraph 6).
7. Needle bar not centered (paragraph 14).
8. Starting position improperly set (paragraph 5).
9. Hook driver set too close to needle (paragraph 15).
10. Race cover too far back (paragraph 16).

Upper thread breaks: (See operating manual).

1. Needle not inserted correctly.
2. Machine not threaded properly.
3. Tension on the upper thread too tight.
4. Knots in thread.
5. Needle too fine for the thread used.
6. Needle bent or point broken. Change needle.
7. Edges of the stitch hole in the throat plate may be nicked and sharp. Either hone them smooth or get a new plate.

Lower thread breaks: (See operating manual).

1. Bobbin case not inserted correctly.
2. Lower thread tension too tight.
3. Bobbin case not threaded correctly.
4. Bobbin wound unevenly.

5. Bobbin wound too fully.
6. Poor quality thread.
7. Damaged hole in the throat plate. Hone or replace plate.
8. Thread wound around center post of rotary hook.

Lower thread does not come up:

1. Needle inserted incorrectly.

Machine sewing poorly:

1. Needle bent or blunted. Insert new needle.
2. Needle inserted incorrectly.
3. Machine threaded incorrectly.
4. Wrong size of needle used.
5. Thread too heavy for the needle.
6. Insufficient pressure on the presser foot, especially when sewing thick fabrics. Turn the pressure regulating screw (9, Fig. 10) to the right.
7. Bobbin wound unevenly.
8. Upper thread tension not adjusted properly.
9. Lower thread too heavy. Should at least be of the same size as the upper thread, or a little finer.
10. Upper thread or needle not suited to the material.

Stitching loosely — with loops at the underside of the material:

1. Machine not threaded correctly.
2. Presser foot not let down properly.
3. Upper thread tension too light.
4. Thread take-up spring bent or broken off. Adjust or replace it. (see Par. 19 and 20).
5. Thread take-up not traveling enough (see Par. 19).

Thread tension uneven:

1. Poor quality thread is a like cause.

Wrinkling of material:

1. Needle thread tension too tight.
2. Needle and bobbin thread tensions too tight for material used.
3. Presser foot pressure too great. Turn regulator screw to left (9, Fig. 10).
4. Thread take-up spring has too much strength (see Par. 20).

Stitches of varying length:

1. Feed dog is clogged with lint. Clean it out.
2. Worn teeth in feed dog. Replace feed dog.

Loosely stitched seams:

1. Upper (needle) and lower (bobbin) thread tensions too loose. (See operating Manual).

Cloth gets chewed up:

1. Too much pressure on the presser foot. Reduce by turning the pressure regulating screw (9, Fig. 10) to the left.

Recommended order in which to check a machine thoroughly and quickly

(Follow this order when stitching-in each new machine or investigating each service complaint.)

1. Be sure proper needle is properly installed.
2. Wind bobbin and thread machine properly with number 50 thread.
3. Pull bobbin thread through hole in throat plate. Pull thread with fingers. There should be a light tension (paragraph 21).
4. See that thread pulls freely through upper tension when presser bar is raised. Then lower the presser bar and pull thread through upper tension. There should be a slight tension on upper thread (paragraph 18).
5. Check timing of hook. When take-up lever is at its lowest position, the tip of the hook should be directed below the centre post of the hook. That is, if the race front cover were the face of a clock, the tip of the hook would be at 6 o'clock. A more accurate method of checking this timing is found in paragraph 12.
6. Check height of needle bar. Set controls to right needle position and straight sewing settings. Turn handwheel until needle is on the upstroke and tip of hook is at centre line of needle. Needle eye should be just 1 mm below tip of hook (paragraph 13).
7. Check height of presser bar and alignment of presser foot (paragraph 17).
8. Check height of feed teeth (paragraph 9).
9. Check timing of feed. On long stitch setting, material should stop moving just as the needle enters the cloth (paragraph 6).
10. Check hook clearance between shuttle driver and race front cover. (Paragraph 16).
11. Be sure all set screws are re-tightened. Then sew-test the machine.

1. Adjusting the end play (lateral movement) of upper main shaft

COMPLAINT: Class 21 and 51

Clicking or knocking sound when zigzagging.

CORRECTION: Loosen set screws 1 (Fig. 1). Pull handwheel away from machine at the same time moving the thrust collar 2 (Fig. 1) against bearing. Then retighten the set screws.

NOTE: On the class 21-A, the thrust collar is located next to the handwheel.

COMPLAINT: Class 21, 51, 71 and 7

Machine runs slow.

CORRECTION: It is possible the thrust collar is running too tightly against bearing. Loosen set screws to relieve pressure. Before you do this correction, you have better to look for other reasons why the machine runs slow.

NOTE: On the class 21-A, the thrust collar is located next to the handwheel.

CORRECTION:

It is possible that the slide block (6 Fig. 4) is positioned too far toward the needle end of the machine and is thereby forcing the feed fork too tightly against the feed cam (5 Fig. 4). Move the slide block slightly toward the handwheel of machine to allow slight clearance between feed fork and feed cam. It is necessary to loosen the screw holding the clamp (7 Fig. 4) to make this correction, and retighten it after the correction has been made.

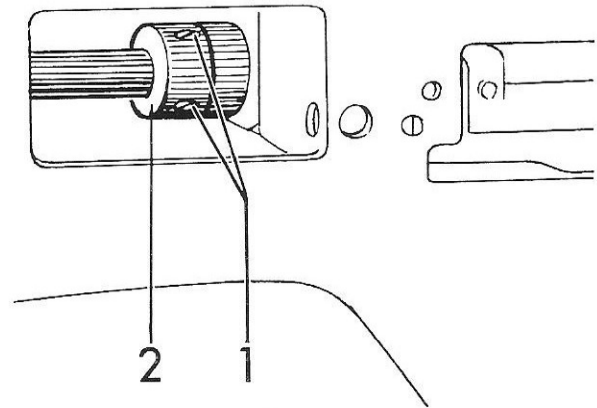

Fig. 1

2. Adjusting mesh (or mating) of worm gear and camstack shaft spur gear

COMPLAINT: Class 21 and 51

Clicking or knocking sound when machine is zigzagging and/or needle bar jumps swiftly toward the right when on the upward stroke.

CORRECTION: Loosen two sets screws 2 (fig. 2) and move worm gear 1 along main shaft toward the spur gear 3 until it meshes properly with this gear. Thrust collar 4 must be replaced so that it is lying tightly against the spur gear 3. After the correction it is necessary to control timing of the zigzag mechanism. (See paragraph 4 page 4.)

COMPLAINT: Class 21 and 51

Machine runs slow.

CORRECTION: If worm gear 1 and spur gear 3 have too tight a fit, it is necessary to move worm gear along shaft slightly and away from the spur gear to allow the machine to run more freely. You must first move the thrust collar 4 and after the correction move it tightly against the worm gear 1. Then you have to control timing (paragraph 4).

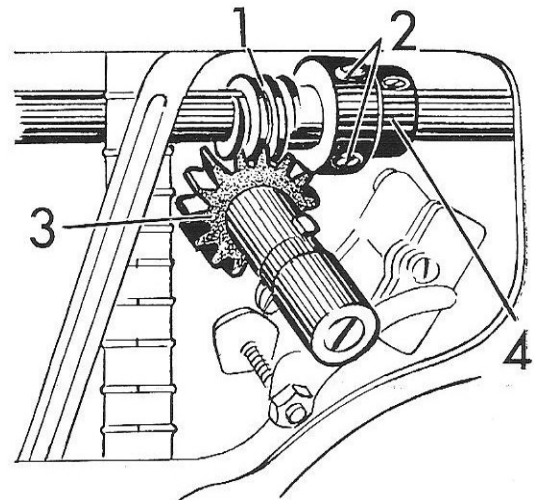

Fig. 2

3. Setting the pattern cam set with respect to the cam follower

COMPLAINT: Class 21 and 51

Machine does not produce pattern according to instruction manual, or produces combination of two patterns.

CORRECTION: The cam guide (1, Fig. 3) determines the lateral position of the pattern cam set. Loosen screw (2, Fig. 3) on the spacer sleeve and shift the cam guide in or out. Then tighten the screw and check the cam follower (3, Fig. 3) to make sure that it cannot ride two pattern cams at a time.

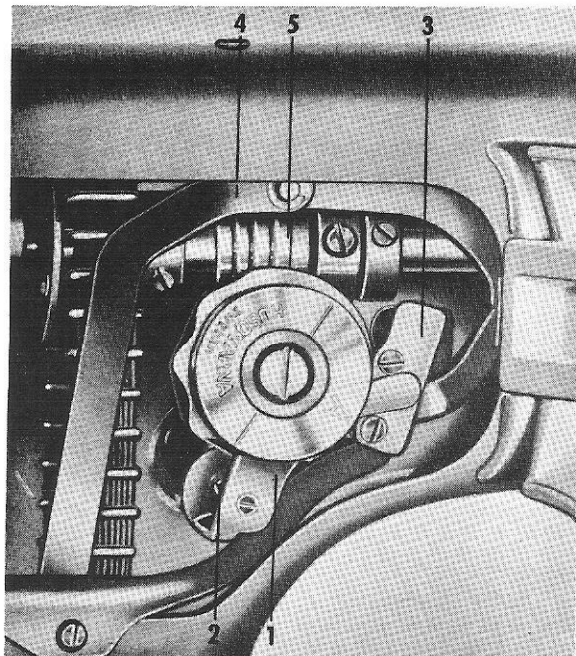

Fig. 3

4. Timing the zig-zagging mechanism

COMPLAINT: Class 21 and 51

Needle moves sideways before it is free of the cloth.

CORRECTION: Set the machine for maximum needle swing, centre starting position, and pattern cam 5. Loosen the screws on the worm (2, Fig. 2) and turn it to make the setting. Tighten the screws and see that the needle bar swing frame comes to the end of its stroke (in both directions) before the tip of the needle comes within $9/32$ " (7 mm.) of the throat plate.

5. Setting needle bar starting position

COMPLAINT: Class 21 and 51

Needle bar too far to right or left of needle plate hole. Full width stitch patterns shift to right and left when needle position knob is moved right or left. Needle bar does not travel full width when on maximum width setting on pattern 5.

CORRECTION: Set for left-hand starting and pattern cam 5. Turn the handwheel until the cam follower (1, Fig. 4) is riding a lobe on the pattern cam. Loosen screw (2, Fig. 4) and adjust the cam follower setting at its pivot centre. Then tighten the screw and turn the stitch selector knob from 0 to 4; the needle should not move when the knob is turned.

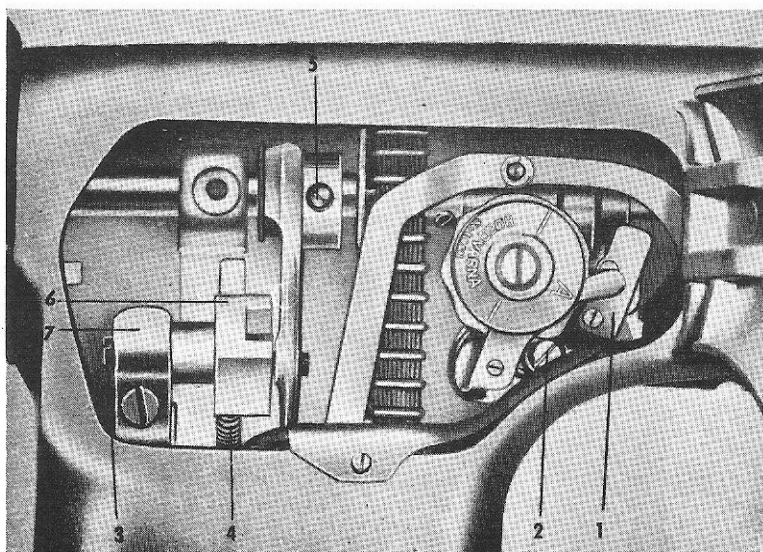

Fig. 4

6. Timing axial feeding motion of feed dog

COMPLAINT: Class 21, 51, 71 and 7

Needles strike needle plate because cloth continues to feed after needle has entered cloth, or, With normal tension settings, an occasional loop stitch is found on underside of cloth on long stitch setting.

CORRECTION: This adjustment is easier to make when the machine is set for maximum stitch length. Turn eccentric (5, Fig. 4) to a setting where the feed movement stops an instant before the needle goes into the cloth. See that this is also the case when the machine is sewing backwards.

7. Setting the needle bar for straight sewing

COMPLAINT: Class 21 and 51

Cam follower does not fully retract away from camstack when width control is set at 0.

CORRECTION: Set width at 0. Loosen lock screw 2, (Fig. 5) located on underside of width control knob. Take hold of the follower bar 4 (Fig. 3) and pull it upward until it fully retracts the cam follower 1 (Fig. 4) away from the camstack. Then retighten lock screw 2. The cam follower should leave the pattern cam set every time the needle swing control is turned to 0. Be sure this is the case, even when the needle bar is in the right-hand starting position.

8. Adjusting friction of stitch length regulator guide

Class 21 and 51.

The adjustment is made by turning screw (3, Fig. 4) on the guide, which is under pressure from the friction spring. The screw is held in position by the stitch regulator lever (4, Fig. 4) which must be loosened for the adjustment and then re-tightened.

Class 21-A.

On the class 21-A the regulator guide is held in place by a set screw instead of a clamp. Adjustment of the amount of tension on the spring which returns the guide to forward sewing position is accomplished by loosening the set screw and turning the slotted bushing (located at position 3 Fig. 4) to the left to increase tension and to the right to lessen tension. Be sure the reverse pushbutton works freely before final re-tightening of set screw.

9. Vertical setting of the feed dog height

Class 21

When the feed dog is at the highest point, the tips of its teeth should be $3/64$ in. (1 mm.) above the level of the throat plate. To adjust the height, turn lever (S-11599 Fig. 6) on the feed dog rocker rod (S-11598 Fig. 6). Screw 1 (Fig. 6) must be loosened to make this setting, and then tightened again. In order to make these adjustments, the door in the bed plate must be taken off.

If you have gauge #4T-32507 as shown in Fig. 6-A, it will give the proper height of $3/64$ " (1 mm) of feed teeth above top level of the throat plate as shown in Fig. 6-B.

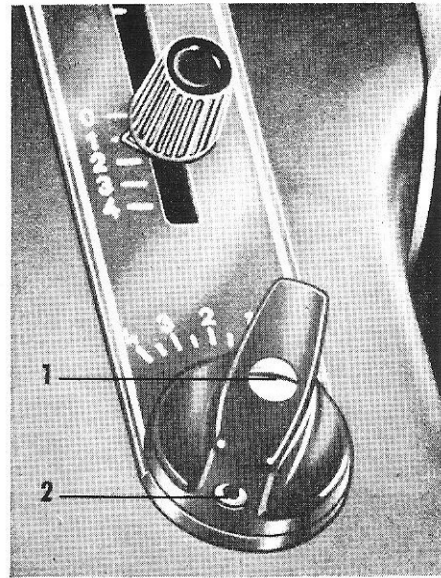

Fig. 5

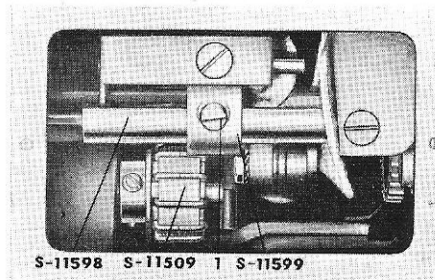

Fig. 6



Fig. 6 A

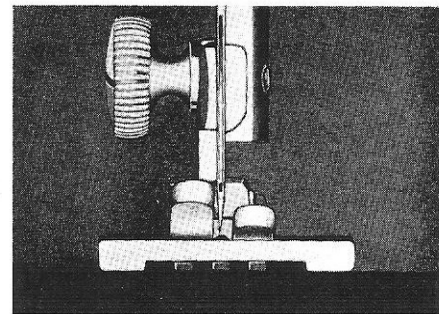

Fig. 6 B

9. Vertical setting of the feed dog height (con't)

CLASS 51, 71 and 7

When the feed dog is at the top of its stroke, the tips of the teeth should be almost $3/64''$ (1 mm) above the surface of the throat plate. The adjustment is made by backing off screw (2, Fig. 7) and moving the taper block (1, Fig. 7). Then retighten the screw.

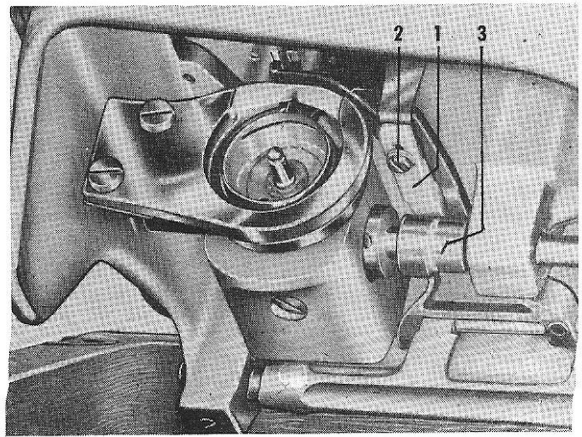

Fig. 7

10. Setting the axial position (forward and reverse position) of feed dog

COMPLAINT: Feed dog touches the front or rear of opening in needle plate, when on longest stitch length setting.

CORRECTION: Class 21

Turn lever clamp (1, Fig. 11) on its shaft (2, Fig. 11). Loosen screw (3, Fig. 11) for this setting and tighten it again afterwards.

CORRECTION: Class 51, 71 and 7

Back off screw (1, Fig. 8) cautiously, and turn the feed dog rocker bar (2, Fig. 8) to make the adjustment. Then tighten the screw and check the setting: with the machine set for maximum stitch length, the feed dog should have equal clearance to both ends of the opening in the throat plate, in sewing both forwards and backwards.

11. Lateral (sideways) positioning of feed dog in throat plate

COMPLAINT: Side of feed dog rubs against opening in the throat plate.

CORRECTION: Class 21

Loosen the nut (4, Fig. 11) and the corresponding locking nut at the opposite side of the feed dog rocker arm (6, Fig. 11). Turn the screw (5, Fig. 11) to the left and turn the corresponding screw (hexagonal) in the opposite part of the feed dog rocker arm to the right. This refers to the cases when the feed dog has to be moved to the left. If the feed dog has to be moved to the right the screws have to be turned in the opposite direction in the opposite order. When the feed dog has been moved the locking nuts 4 and the corresponding nuts in the opposite part of the feed dog rocker arm have to be fastened.

CORRECTION: Class 51, 71 and 7

Loosen the (3, Fig. 8) set screws and move the bearings that support the ends of the feed dog rocker arm #S-13027, (2, Fig. 8).

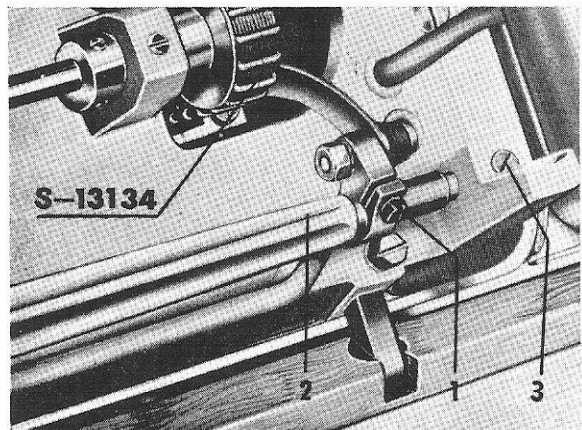

Fig. 8

12. Timing the sewing hook

COMPLAINT: The machine does not sew. It forms skipping stitches. It forms looping stitches. Thread breaks.

CORRECTION: Class 21.

Loosen the three set screws holding the lower cog wheel S-11509 (Fig. 6) to the lower arm shaft. Then set needle bar for straight stitching in right-hand needle position and turn handwheel in regular sewing direction until the needle is on the upstroke and has risen $5/64''$ to $3/32''$ (2 to 2.5mm.) above lowest dead centre (Fig. 9). Then turn hook until the tip of hook is in line with the centre of the needle. Retighten set screws on S-11509 cog wheel.

CORRECTION: Class 51, 71 and 7.

Same as for Class 21, except that cog wheel S-13134 for these models is pictured in Fig. 8.

Note: A rough and fast method of checking timing on all Class 21, 51, 71 and 7 machines is to turn the handwheel until the end of the take up lever (10, Fig. 10) is at its lowest position. If the tip of the hook is then at its lowest point (i.e. below and in a vertical line with the centre post of the hook), look elsewhere in the machine for any difficulty before re-timing the hook.

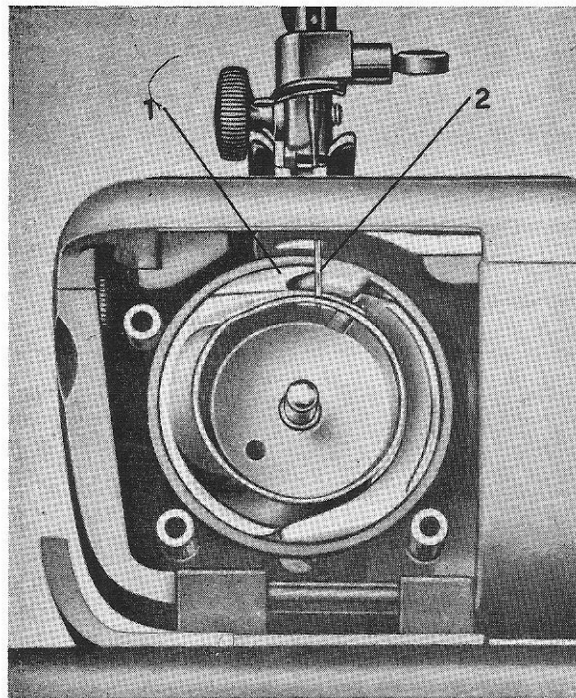

Fig. 9

13. Setting the needle bar height

COMPLAINT: All Models. Skipping stitches. Looping stitches. Thread breaking.

CORRECTION: All Models. Set needle bar for straight sewing in right hand needle position. Turn handwheel in regular sewing direction until needle is on the up-stroke and the tip on the hook is at the centre line of the needle. Then loosen screw (5, Fig. 10) and raise or lower needle bar until the top of needle eye is 1 mm below tip of hook.

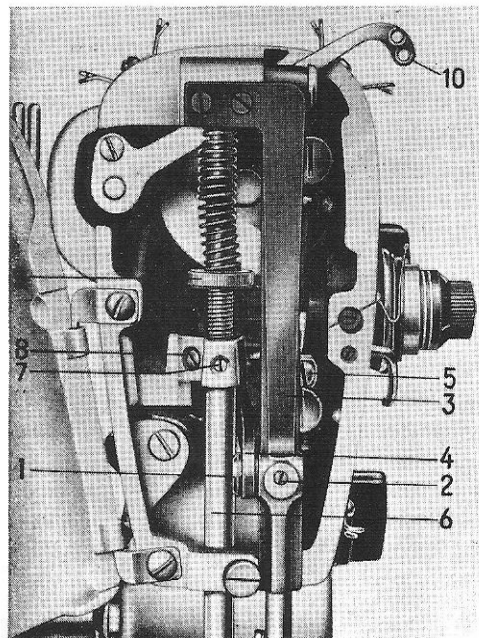

Fig. 10

14. Centering the needle in the throat plate

COMPLAINT: Class 21 and 51.

Needle not centered in throat plate.

CORRECTION: Class 21 and 51.

Insert a new needle. Loosen screw (2, Fig. 10) and turn eccentric (1, Fig. 10) which serves as the bearing between the needle bar frame and the link from the zig-zag drive, until the needle is centered in the throat plate hole. On zig-zag stitch with 4 width the needle should have equal clearance on each side of the throat plate hole.

Note: If this does not correct the lack of clearance on one side of the throat plate hole, refer to paragraph 5, page 2.

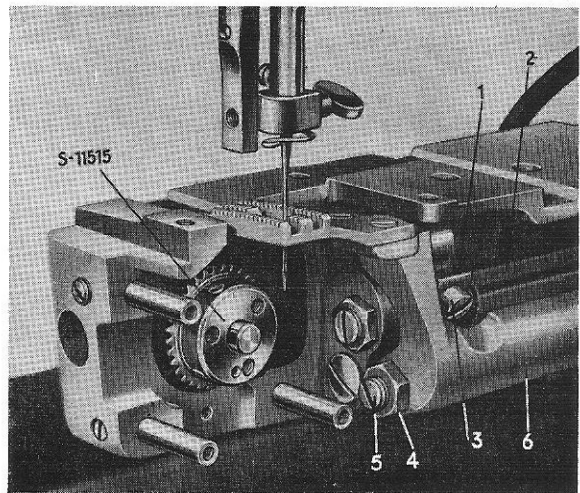

Fig. 11

15. Setting clearance between sewing hook and needle

COMPLAINT: Class 21, 51, 71 and 7.

Needle makes scraping (rubbing) sound against hook. Needle being bent toward operator by hook. Skipping stitches by reason the needle is too far from sewing hook tip.

CORRECTION: Class 21.

Use needle No. 90 (#16). Set the hook and the needle in the same positions as in Fig. 9. When the hook is pressed inwards towards the driver S-11526, its tip should clear the needle by about .01 in. (0.2 mm). If the hook is too far from the needle, loosen the driver from gear (S-11515, Fig. 11) and insert one or more washers S-11539 between the driver and the gear. If the hook is too close to the needle, remove washers S-11539 as necessary.

CORRECTION: Class 51, 71 and 7.

Use a No. 90 (#16) needle; turn the handwheel until the needle is in front of the tip of the shuttle. When the shuttle is pressed inside the driver S-13051, its tip should clear the needle by about .01" (0.2 mm). If the clearance is not correct, loosen the driver and adjust its position by placing spacer washers #S-13050 between the gear (1, Fig. 12) and the driver. When the driver is shifted, the shuttle cover S-13055 must also be moved. To do this, see instructions under Sect. 16.

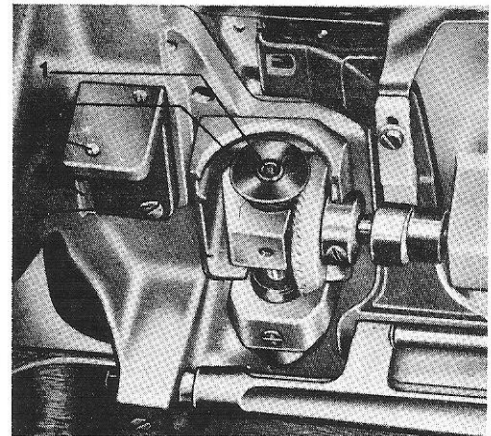

Fig. 12

16. Adjusting shuttle (hook) cover

COMPLAINT: Class 21, 51, 71 and 7.

Hook comes out of notch in driver. Thread does not pass freely around hook.

CORRECTION: Class 21.

Insert hook clearance gauge (Fig. 13) in place of hook and replace race cover S-11527. Remove arm cover plates and loosen set screws (1, Fig. 14). Tap gently or press the race front S-11527 down against the hook gauge until it is in such position that the gauge can be turned with some friction. Retighten set screws (1, Fig. 14).

CORRECTION: Class 51, 71 and 7.

Replace the hook with the hook gauge (Fig. 13). Loosen set screws (1, Fig. 15) and press or gently tap the race front against the hook gauge until the hook gauge can be turned with some friction. Retighten set screws (1 Fig. 15).

HOOK CLEARANCE GAUGE #4T-33243

Gauge #4T-33243

Fig. 13

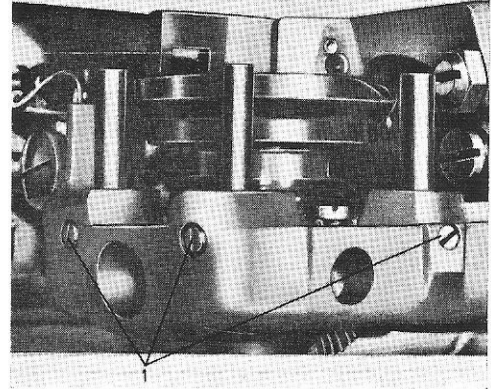
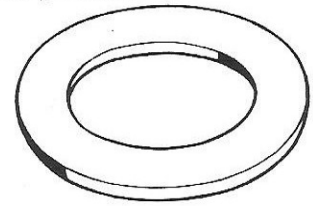

Fig. 14

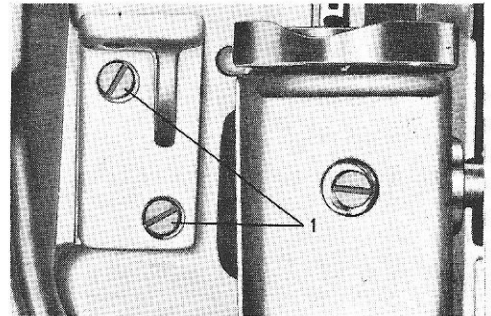

Fig. 15

17. Setting the proper height of presser bar

COMPLAINT: Class 21, 51, 71 and 7.

- a. Needle clamp strikes presser foot when machine is run with the presser foot in raised position.
- b. Presser foot does not sit firmly on top level of throat plate when in lowered position and feed dog teeth below surface of throat plate.

CORRECTION: Class 21, 51, 71 and 7.

Raise presser bar lifter thereby raising presser foot. Drop the feed dog below surface of the throat plate. Raise or lower the presser bar until the bottom of the presser foot rests on top of the gauge #4T-34146 (Fig. 16) which has been placed on its narrow edge. To make this adjustment on Class 21 and 51, loosen set screw (4, Fig. 17) and on class 71 or any model with the patchomatic device, loosen set screw (2, Fig. 18), retightening the set screw after making the setting. Before tightening, be sure that the presser foot is properly aligned with the rows of teeth on the feed dog. If you do not have this gauge, the distance equal to the height of the gauge as shown in Fig. 16 is $\frac{1}{4}$ " (7 mm).

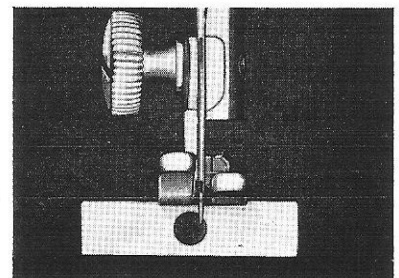

Fig. 16

18. Setting upper thread tension release

COMPLAINT: Class 21, 51, 71 and 7

- Tension does not release when presser bar is raised with the lifter.
- Upper thread tension is loose regardless of adjustment made to upper tension regulating knob.

CORRECTION: Class 21, 51, 71 and 7

Loosen screw (1, Fig. 20) and move entire upper tension assembly (barrel) inward or outward (in direction of arrows in Fig. 20) so that upper tension will release when presser bar is raised, and also release bracket S-11693 (Fig. 19) will retract fully from the release pin as the presser bar is in lowered position.

19. Setting the amount of travel of the take-up thread regulating spring

COMPLAINT: Class 21, 51, 71 and 7.

- With proper tension settings the stitches are loose on top of material. This might indicate that the take-up thread regulating spring stops too soon, i.e. does not travel enough.
- Skipping stitches when hook and needle height are properly adjusted. (This could indicate that the thread take-up regulating spring stops too late, i.e. travels too far.)

CORRECTION: Class 21, 51, 71, and 7.

The thread take-up regulating spring should keep tension on the upper sewing thread (to take up the slack) until the point of the needle starts to enter the material being sewn. To adjust, loosen screw (1, Fig. 20) and insert screwdriver into the end of the tension stud. Then turn the entire tension assembly with the screwdriver to a position where the thread take-up spring stops moving before the needle starts to enter the cloth being sewn. Retighten set screw (1, Fig. 20).

20. Setting the amount of tension (strength) of the thread take-up spring

COMPLAINT: Class 21, 51, 71 and 7

The thread regulating spring has low tension and always lies in its lower position or has too hard a tension and always lies in its upper position.

CORRECTION: Class 21, 51, 71 and 7.

Loosen screw indicated by arrow (Fig. 21). Insert another screw-driver between the prongs of the tension stud and turn to the right to increase the strength of the take-up spring, or turn stud to the left to reduce strength of take-up spring. Be sure to press the tension knob inward toward the machine to seat the stud in the tension barrel before retightening screw indicated by the arrow.

CORRECTION: Class 21A

The correction is the same as for other models except that the entire tension assembly must be removed from the machine in order to reach the set screw holding the tension stud in the tension barrel. Loosen screw (1 Fig. 20) to remove tension assembly from machine. When re-installing tension assembly make certain the settings in Paragraphs 18 and 19 are properly made.

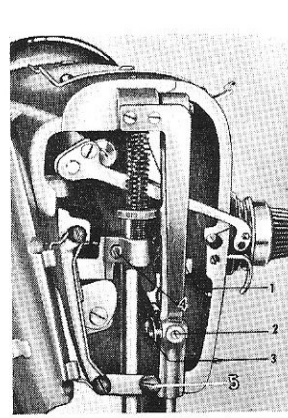

Fig. 17

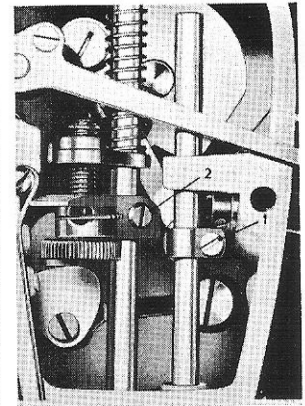
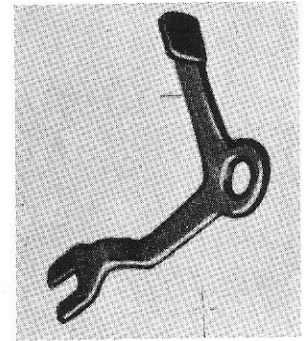

Fig. 18



S-11693

Fig. 19

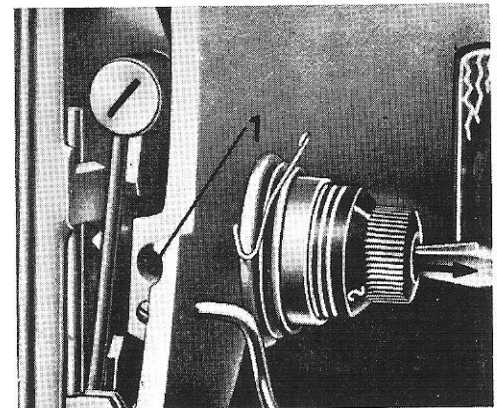

Fig. 20

21. Adjusting the lower bobbin case thread tension.

Class 21, 51, 71 and 7.

Fluff from the thread may be collected under the bobbin case spring, with the result that the lower thread cannot be properly tensioned despite tightening with the screw, (2, Fig. 21a). Screw off the spring and with the feed dog brush, clean its underside, the bobbin case where the spring is located and also interior of case itself. Then attach the bobbin case spring and adjust the thread tension until it is correct.

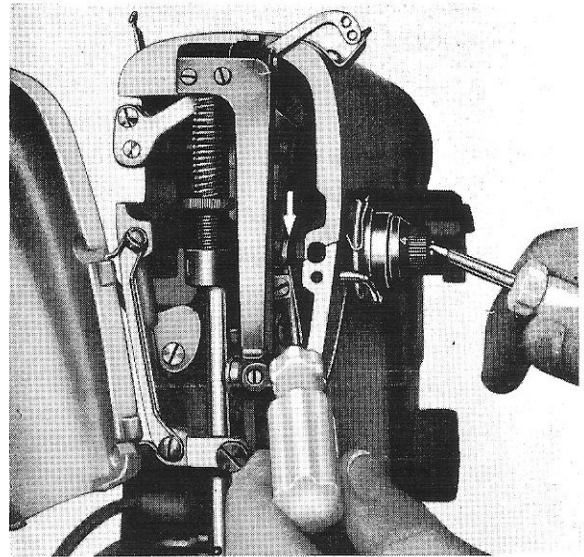

Fig. 21

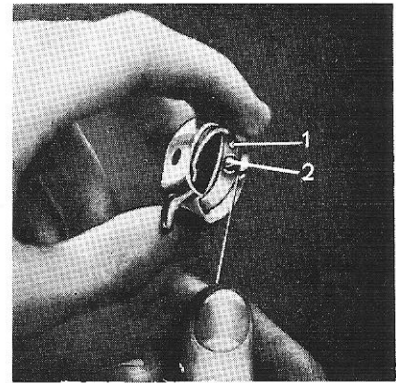

Fig. 21 A

22. Removing the drive belt

Class 21.

Remove belt guard S-11892. Remove screw (1, Fig. 22) and unhook spring 5 below the reduction gear from bracket (3, Fig. 22). Remove belt from pulley and remove the reduction gear. Loosen screw in center of handwheel and remove handwheel and belt as shown in Fig. 22.

Class 51, 71 and 7.

Remove screw in center of handwheel. Remove washer under the screw and then the handwheel itself.

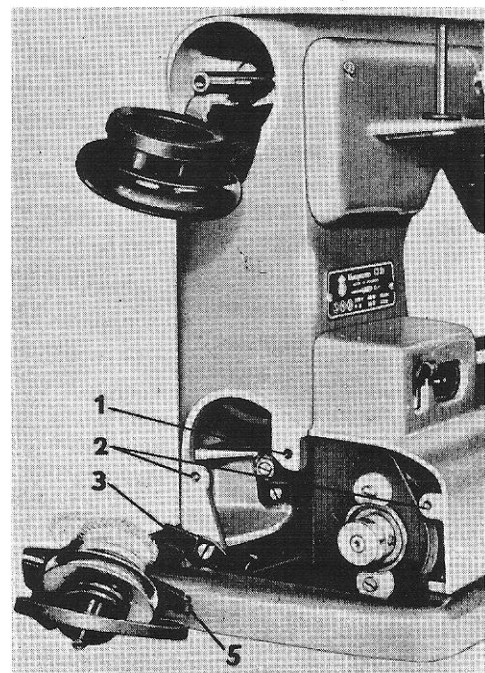

Fig. 22

23. How to dismantle the reduction gear unit on class 21

- a. Remove reduction gear unit from machine (see paragraph 22).
- b. Loosen the two set screws (E, Fig 23) that hold pulley C to shaft A.
- c. Remove C-washer 2895-205 (G, Fig. 23) and also the washer and spring and upper gear (F, Fig. 23).
- d. Remove shaft S-11882 (A, Fig. 23). Reduction gear is re-assembled in reverse order of the foregoing.

24. Adjusting limit of travel of needle bar swing frame.

COMPLAINT: Class 21 and 51.

- a. Needle bar carrier swings too far left, allowing excessive needle bending. This usually would cause the face plate door to swing open.
- b. Needle bar carrier does not swing to the left sufficiently. This causes the cam follower (1, Fig. 4) to bind against lobe of cams.

CORRECTION: Class 21 and 51.

Later models of class 21 and 51 are supplied with an adjustable bracket designed to limit the amount of swing of the needle bar carrier. This bracket is adjusted by turning screw (5, Fig. 17) to the right to limit the swing and to the left to allow more swing.

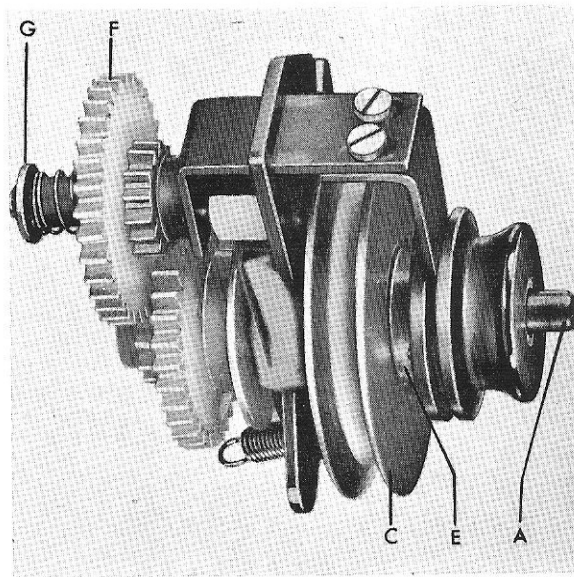

Fig. 23

