

SERVICING MANUAL

***MODEL
640
641***

CONTENTS

PARTS LIST	1 ~ 11
TO POSITION PATTERN SELECTING CAM	12
TO POSITION ZIGZAG WIDTH REGULATING CRANK	13
TO POSITION AUTOMATIC REVERSE SELECTING CAM	14
TO CORRECT STAGGERED STRAIGHT STITCH	15
ADJUSTMENT FOR TIMING OF NEEDLE SWING	16
TO ADJUST NEEDLE DROP POSITION IN NEEDLE HOLE	17
ADJUSTMENT OF "M" NEEDLE POSITION	18
TO POSITION PRESSER BAR	19
ADJUSTMENT OF CLEARANCE BETWEEN NEEDLE AND HOOK	20
ADJUSTMENT OF HEIGHT OF NEEDLE BAR	21
ADJUSTMENT OF HOOK TIMING	22
ADJUSTMENT OF LOWER SHAFT THRUST PLAY	23
ADJUSTMENT OF FEED LIFTING CAM POSITION	24
ADJUSTMENT OF HEIGHT OF FEED DOG	25
ADJUSTMENT OF PITCH DIFFERENCE IN FEED BETWEEN FORWARD AND REVERSE STITCHES	26
ADJUSTMENT OF PITCH DIFFERENCE IN STRETCH STITCH FEEDING	27
ADJUSTMENT FOR "O" POSITION OF THREAD TENSION	28
ADJUSTMENT OF BUTTONHOLE SELECTING CAM AND STRETCH STITCH SELECTING CAM POSITIONS	29
ADJUSTMENT FOR BAR-TUCK FEED OF BUTTONHOLE	30
ADJUSTMENT OF THE DIFFERENCE IN FEED BETWEEN RIGHT-SIDE ROW AND LEFT-SIDE ROW OF BUTTONHOLE	31
ADJUSTMENT FOR CUTTING SPACE OF BUTTONHOLE	32

TO POSITION PATTERN SELECTING CAM

- 1 Set stitch width regulator knob at "5" and pattern selector knob at "W".
- 2 Loosen two hexagon socket screws (a & b) on collar of pattern selecting cam.
- 3 Move selecting cam axially to position the follower of zigzag width transfer rod to the middle of convex part of basic zigzag cam which is the second cam of the cam block.
- 4 In this condition, turn selecting cam so that screw (a) comes to the top, then adjust the cam to position pin on zigzag width regulating crank to the middle of selecting cam groove as shown below.
- 5 Tighten two hexagon socket screws (a & b).
- 6 Turn pattern selector knob to make sure that it selects each pattern correctly and smoothly.

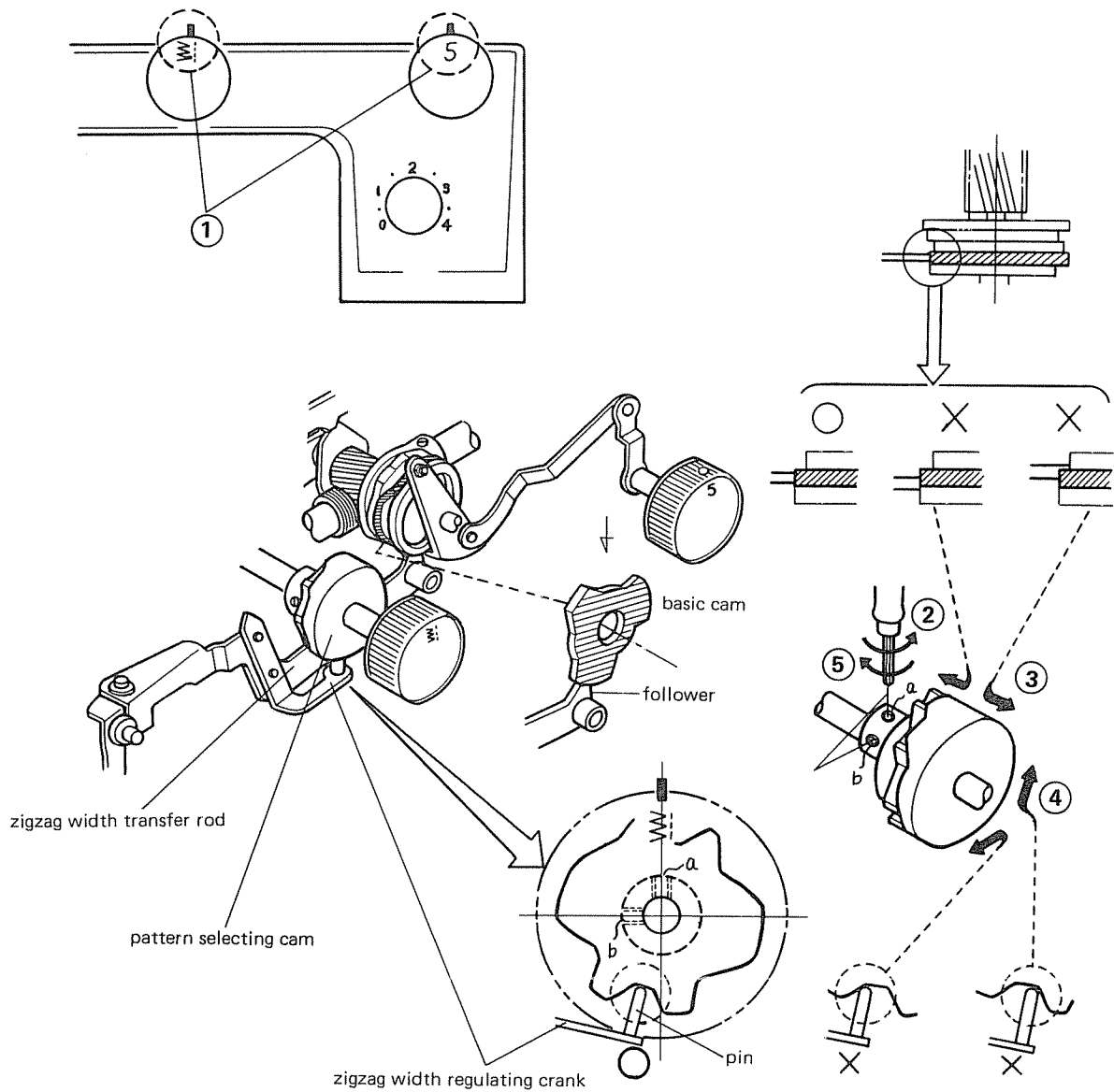

TO POSITION ZIGZAG WIDTH REGULATING CRANK

If pattern selecting is not smooth, make adjustment as follows:

- 1 Set pattern selector knob at “

Note: Make sure the “M” needle position is correct.

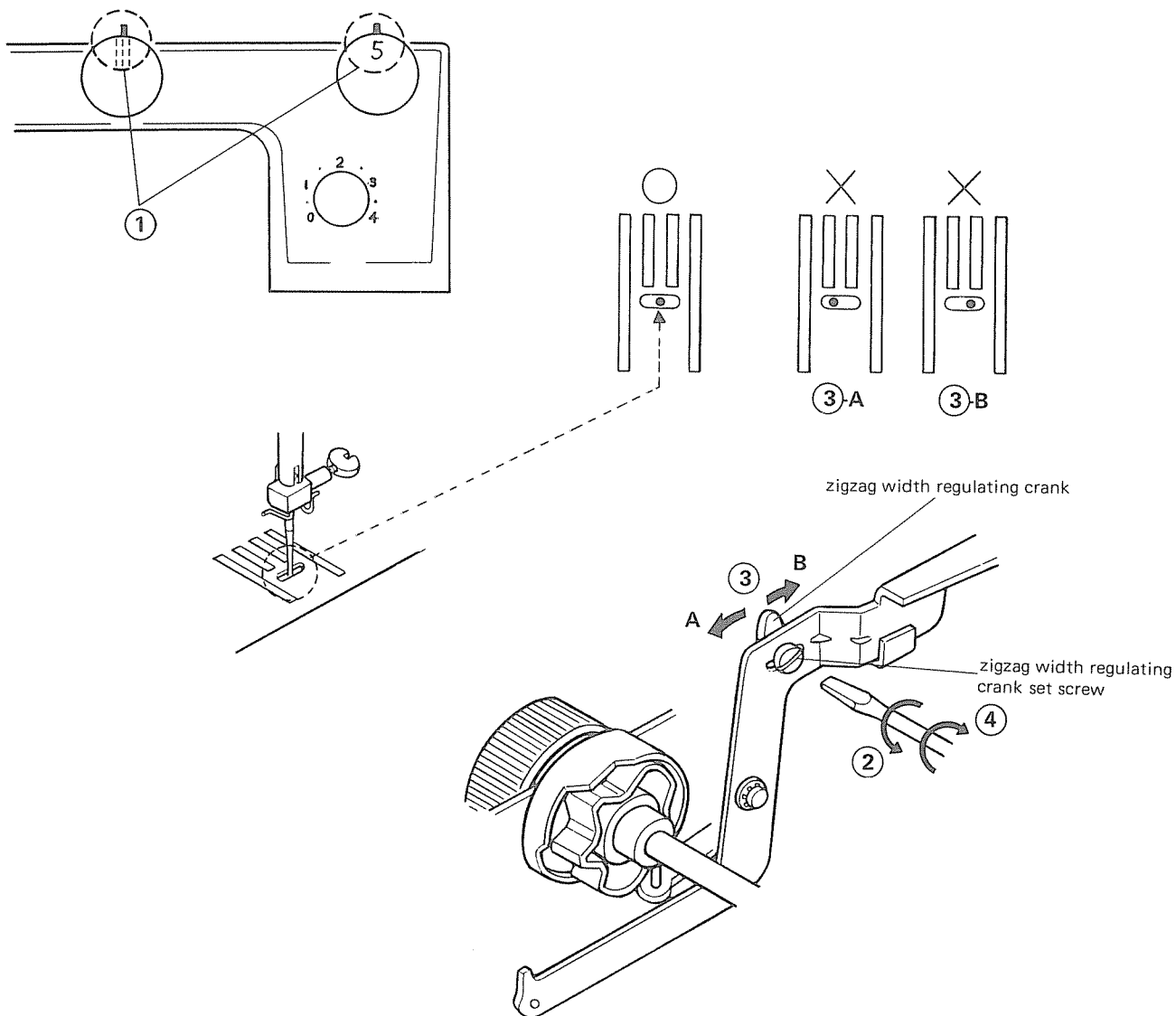

TO POSITION AUTOMATIC REVERSE SELECTING CAM

1. Set pattern selector knob at “”.
2. Loosen set screw on automatic reverse selecting cam.
3. Turn automatic reverse selecting cam so that head of the set screw comes to top.
4. Tighten the set screw.

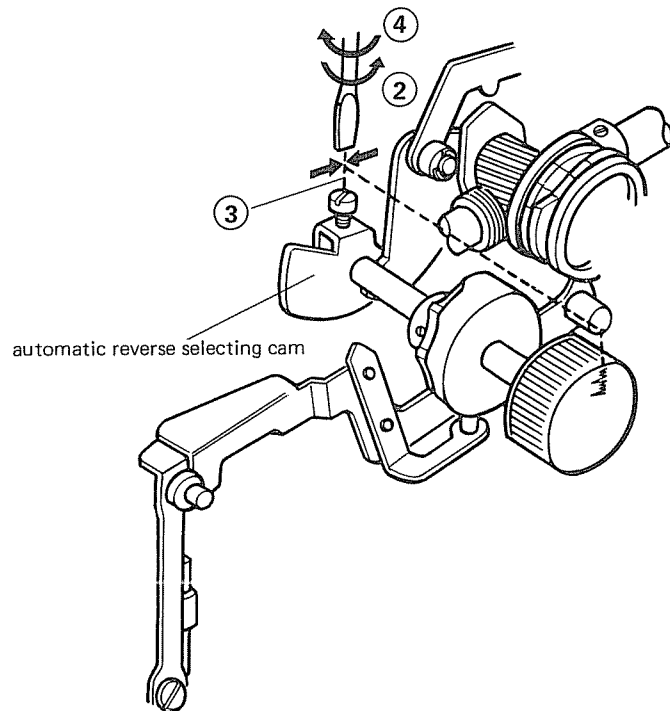
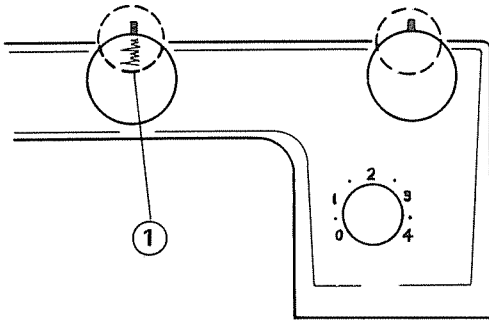

TO CORRECT STAGGERED STRAIGHT STITCH

If zigzag movement of needle bar still remains in straight stitching by setting zigzag width regulator at “0”, make adjustments as follows:

- 1 Set pattern selector knob at “”.
- 2 Loosen two screws of zigzag width regulator knob.
- 3 Turn zigzag width regulating cam in the direction of arrow little by little until zigzag movement of needle bar disappears.
- 4 Set zigzag width regulator knob at “0”.
- 5 Tighten the two screws while holding the knob and dial shaft in the position.

Note: *Make sure that the zigzag width regulator knob turns smoothly after adjustment.

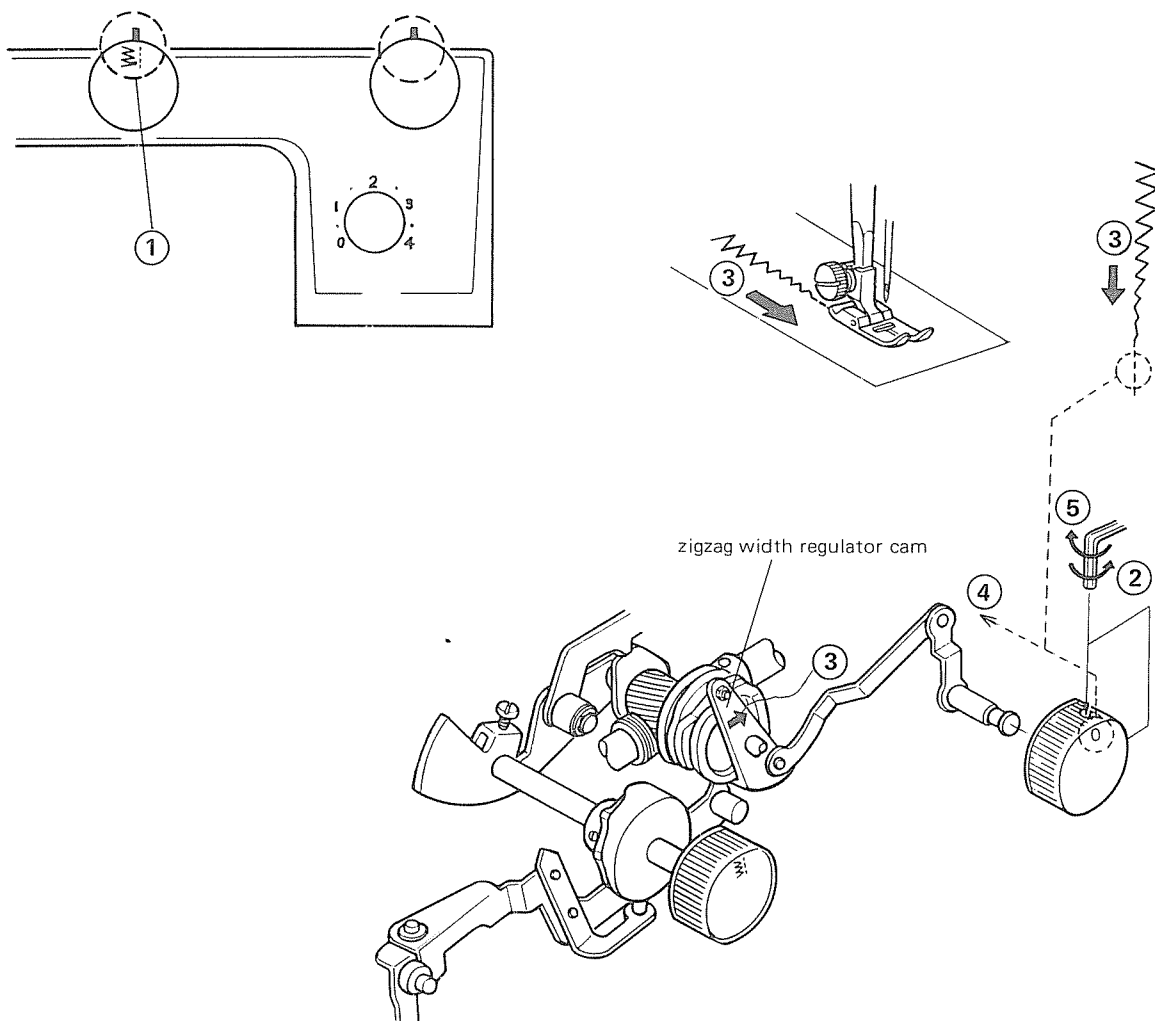

ADJUSTMENT FOR TIMING OF NEEDLE SWING

The rise and fall movement of needle between the lowest position and the upper surface of needle plate should be perpendicular to the upper surface of needle plate. If needle bar is not timed correctly for zigzag stitching, needle will move sidewise while it is still in the fabric. It is ideal that the needle's right outflow starts from the position 2 ~ 3mm (5/64" ~ 7/64") above needle plate.

- 1 Set zigzag width regulator knob at "5" and pattern selector knob at "Z" (zigzag symbol)
- 2 Loosen two set screws for upper shaft worm gear fixing.
- 3 Hold one of the screws at the slot with a screwdriver in order to keep upper shaft worm gear from turning and turn balance wheel toward you to make adjustment. The standard start point of needle's right outflow should be 2 ~ 3mm (5/64" ~ 7/64") above needle plate.
- 4 Tighten two set screws firmly without fail after adjustment.

Note: After adjustment, make sure pitch difference in stretch stitch feeding is correct.

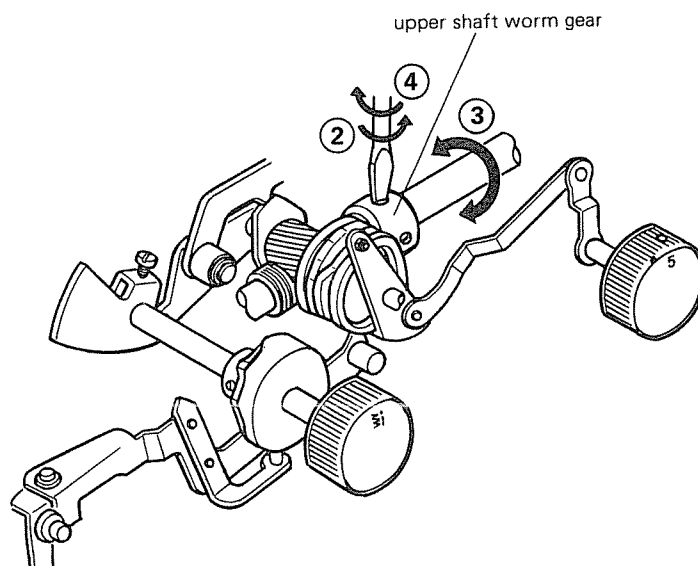
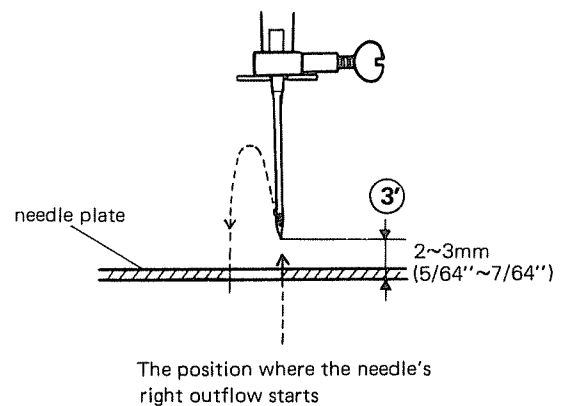
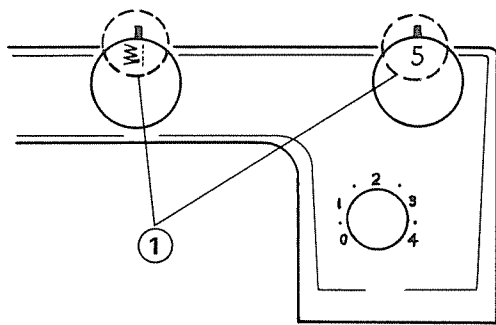

TO ADJUST NEEDLE DROP POSITION IN NEEDLE HOLE

Adjustment of needle drop is made as follows:

- 1 Set zigzag width regulator knob at "0" and pattern selector knob at "  ".
- 2 Loosen set screw for eccentric pin.
- 3 Turn eccentric pin to adjust. The clearance between needle and the left side of needle hole should be 0.3 ~ 0.5mm (1/8" ~ 3/16").
- 4 Tighten set screw.

Note: Replace presser foot with straight stitch presser foot and set stitch width regulator dial at "M" to make sure that needle drop at "M" needle position is correct.

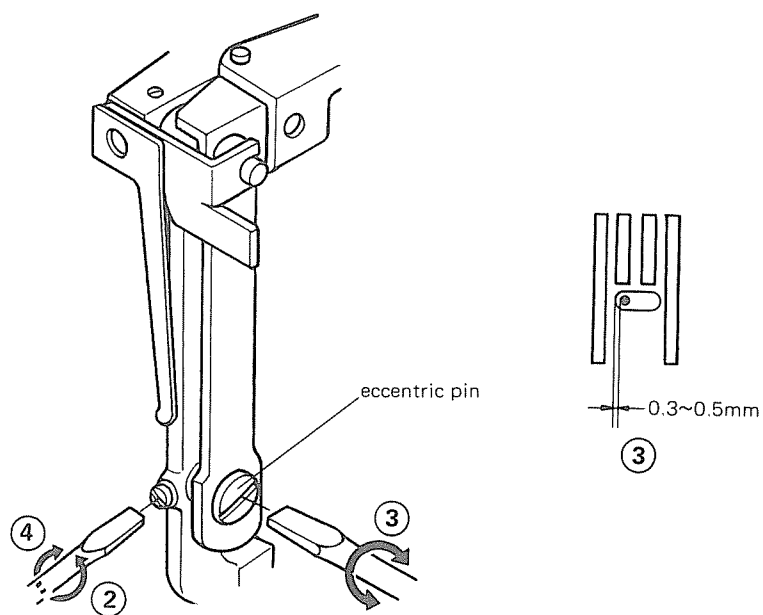
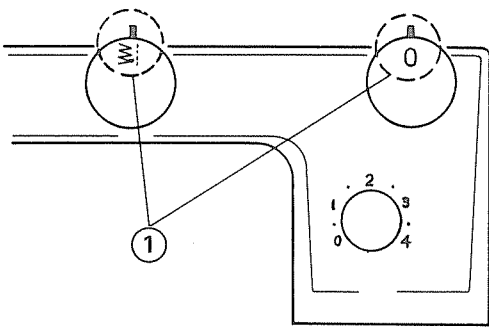

ADJUSTMENT OF "M" NEEDLE POSITION

If needle does not point in the center of needle hole by setting zigzag width regulator knob at "M", adjust the position as follows:

Note: Before adjustment, make sure presser bar position is correct.

- 1 Set the zigzag width regulator knob at "M" and pattern selector knob at "Z".
- 2 Loosen set screw.
- 3 Move "M" needle position cam to adjust position of needle which should be positioned center of needle hole of presser foot.
- 4 Tighten set screw.
- 5 Make sure that straight stitch should not stagger at "M" needle position after adjustment. If it staggers, move the needle drop slightly to the left.

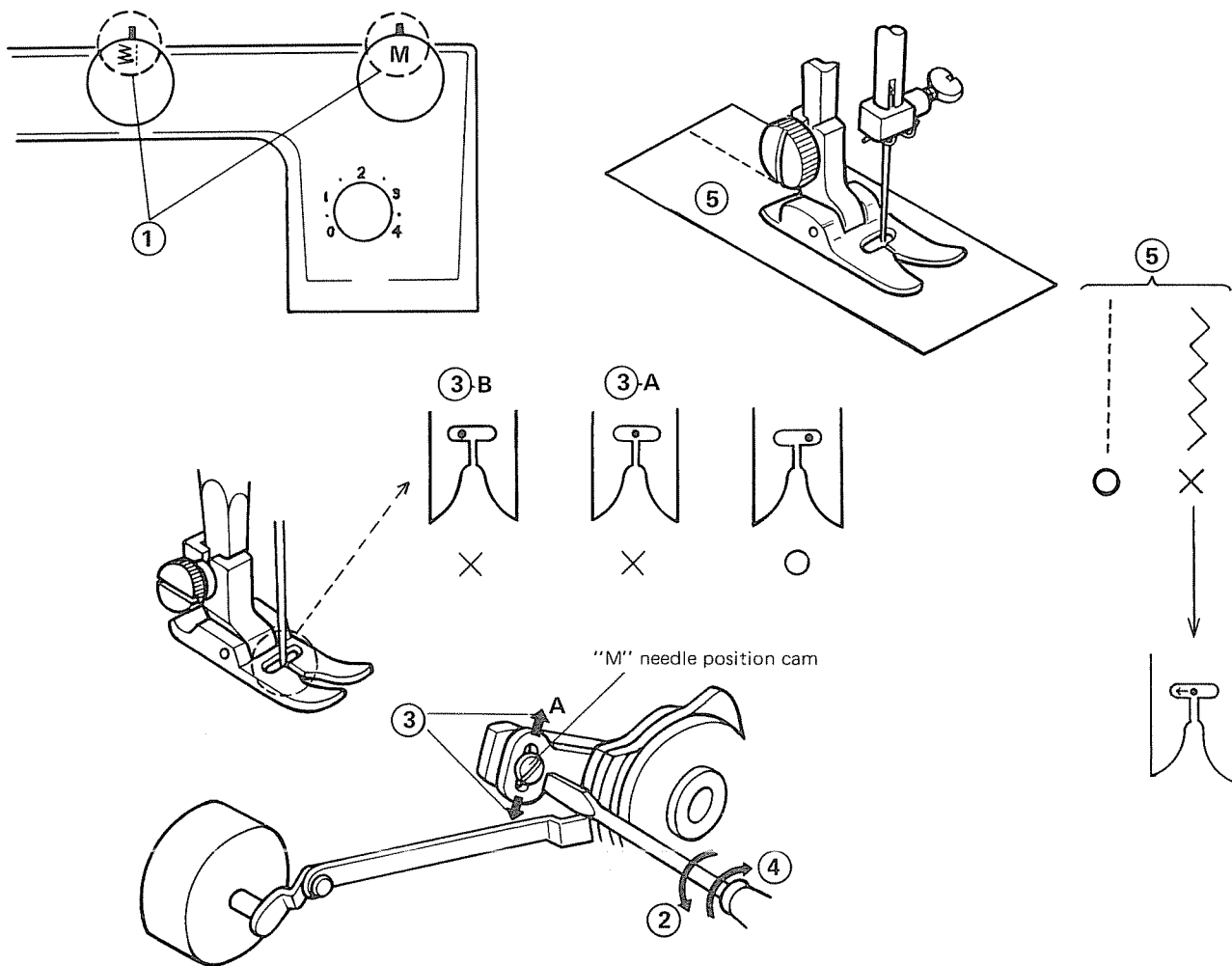

TO POSITION PRESSER BAR

When needle drops in the center of needle hole of presser foot by setting zigzag width regulator dial at “M” and pattern selector knob at “”, the position of presser bar is correctly adjusted.

If not, make adjustment as follows:

- 1 Take off lower set screw of lamp socket unit, loosen upper set screw and tilt the lamp socket unit as shown.
- 2 Set pattern selector knob at “”, and zigzag width regulator knob at “M”.
- 3 Raise presser bar lifter and loosen set screw of presser bar guide bracket.
- 4 Adjust the position of presser bar by moving it so that the sides of presser foot run parallel to the feed dog.
- 5 In this condition, adjust height of presser bar by moving it upward or downward to make clearance between base of presser foot and upper surface of needle plate.
- 6 Tighten set screw of presser bar guide bracket.
- 7 Set lamp socket unit and tighten both set screws firmly.

Note: Make sure that the needle bar supporter spring is correctly positioned on the needle bar supporter.

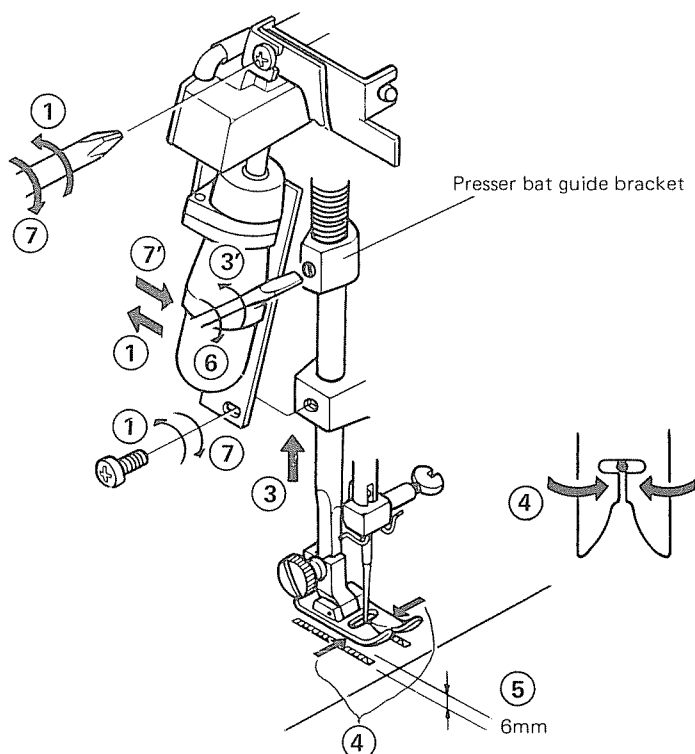
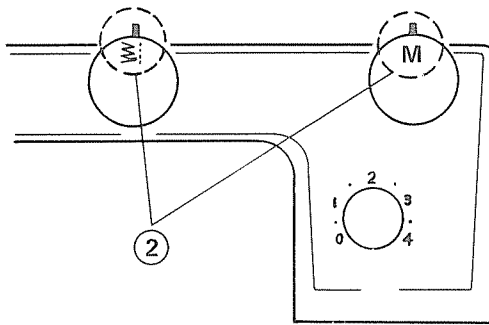

ADJUSTMENT OF CLEARANCE BETWEEN NEEDLE AND HOOK

For perfect stitching the needle must be as near as possible to hook without touching it. Skipped stitches are often caused by incorrect clearance between needle and hook.

The clearance between needle and hook should be 0 ~ 0.15mm (0 ~ 3/512"). Using a perfectly straight needle, test in the following manner:

- 1 Set pattern selector knob at “” and zigzag width regulator knob at “M”.
- 2 Take off bed cover and gear box lid.
- 3 Loosen lower shaft front bushing set screw and move lower shaft 0.5mm to the right. Then, tighten lower shaft front bushing set screw temporarily.
- 4 Loosen shuttle race set screws.
- 5 Adjust the clearance between needle and hook by moving shuttle race body.
 - * Do not turn the shuttle race body when adjusting.
 - * The clearance should be 0 to 0.15mm.
- 6 Tighten shuttle race set screws.
- 7 Loosen lower shaft front bushing set screw and move lower shaft to the left while adjusting backlash of gears.
 - Then, tighten lower shaft front bushing set screw firmly.
 - Note: Make sure that the machine runs smoothly. If not, cause a little more backlash.
- 8 Set bed cover and gear box lid to the body of sewing machine with screws.

Note: After adjustment, check the feed lifting cam position with reference to page 24.

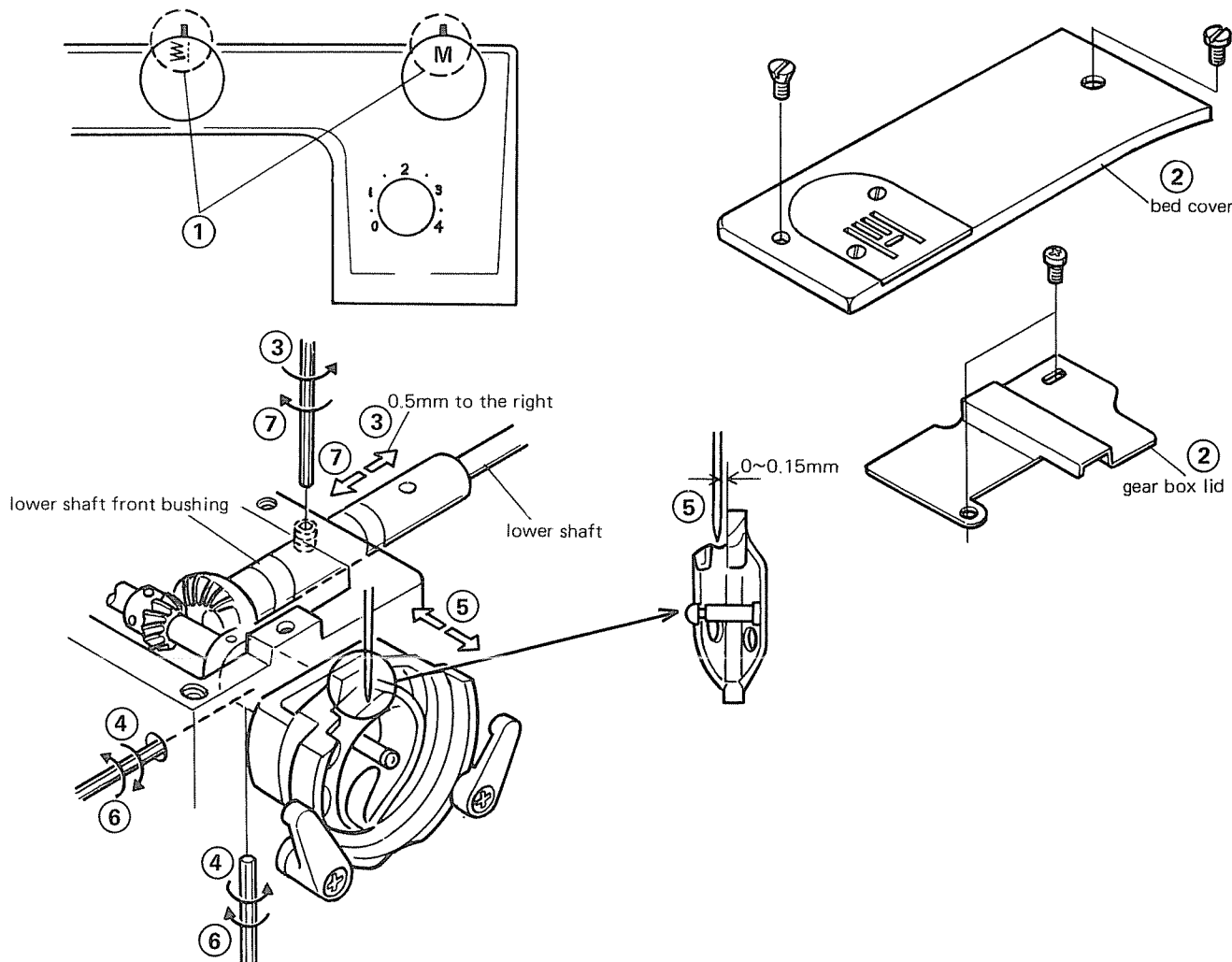

ADJUSTMENT OF HEIGHT OF NEEDLE BAR

Turn balance wheel toward you until needle bar is at its lowest position. Then again turn balance wheel until the tip of hook meets the left side of the needle. The distance between the upper tip of the needle hole and the top of the hook should be 2.9 ~ 3.5mm ($7/64'' \sim 17/128''$).

If not, make adjustment as follows:

- 1 Set zigzag width regulator knob at "0" and pattern selector knob at 1 "".
- 2 Turn balance wheel toward you until the tip of hook comes to the lowest point of its travel and then to the left side of the needle.
- 3 Loosen needle bar connecting stud set screw.
- 4 Move needle bar lengthwise to adjust the height of needle bar by 2.9 ~ 3.5mm.
Note: Do not turn the needle bar when adjustment is made.
- 5 Tighten needle bar connecting stud set screw.

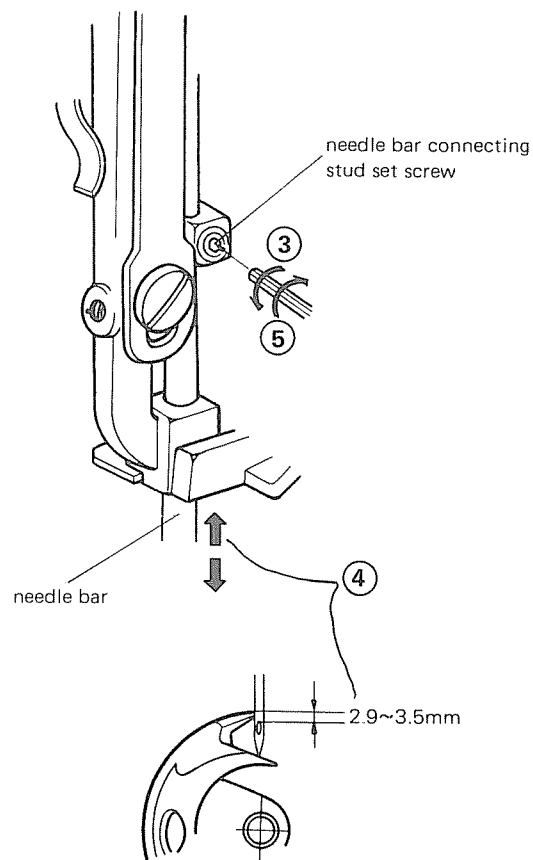
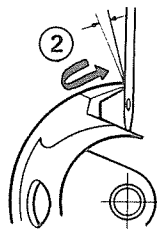
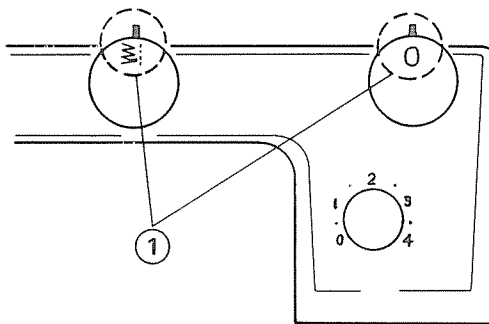

ADJUSTMENT OF HOOK TIMING

Turn balance wheel toward you until needle bar is at its lowest position while zigzag regulator knob is set at “0” and pattern selector knob at “”. Then again turn the balance wheel until the tip of hook meets the left side of the needle.

Amount of this needle bar movement indicates hook timing.

The standard amount should be $1.7 \pm 0.25\text{mm}$.

- 1 Set pattern selector knob at “” and zigzag width regulator knob at “0”.
- 2 Loosen set screw (a).
- 3 Turn balance wheel toward you until needle bar comes to 1.7mm above from its lowest position.
- 4 Loosen set screw (b).
- 5 Hold balance wheel with your hand to prevent turning of upper shaft and turn lower shaft in the direction of arrow until the tip of shuttle hook meets the left side of needle.
- 6 Tighten set screws (a & b).

Note: After adjustment, check the feed lifting cam position with reference to page 24 .

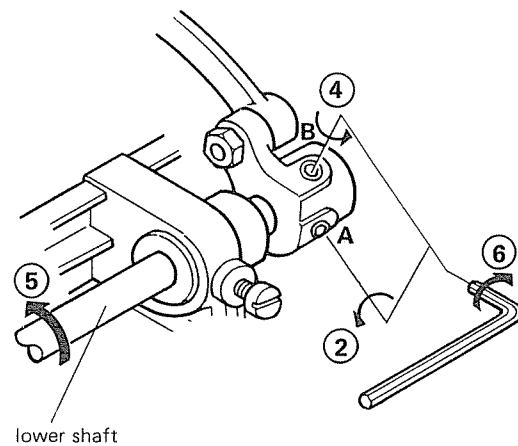
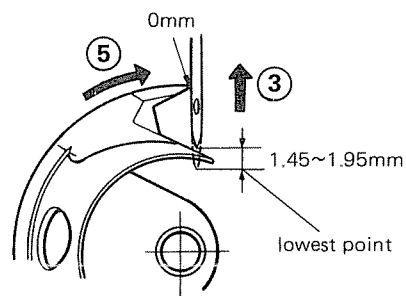
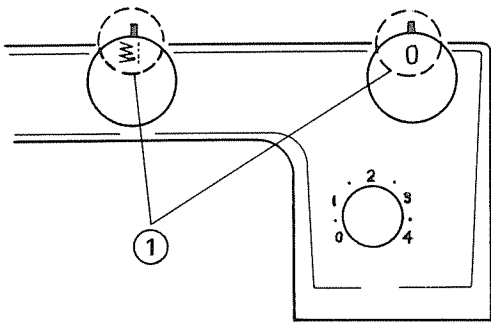

ADJUSTMENT OF LOWER SHAFT THRUST PLAY

If there is a large play on lower shaft in the thrust direction, make adjustment as follows:

* The standard amount of lower shaft thrust play is less than 0.03mm.

- 1 Take off bed cover and gear box lid.
- 2 Loosen feed lifting cam set screw and move feed lifting cam to the right slightly. Then, tighten the screw temporarily.

Note: Do not turn the feed lifting cam when loosening the set screw.

- 3 Loosen lower shaft front bushing set screw and thrust the lower shaft front bushing toward gear while adjusting the play on the lower shaft and backlash of gears.

*The standard amount of backlash is less than 0.3mm at the point of shuttle driver.

- 4 Tighten lower shaft front bushing set screw.

*Check the play and backlash after tightening the screw.

- 5 Loosen feed lifting cam set screw and move the feed lifting cam to the left until it touches lower shaft front bushing.

Then, tighten the set screw.

Note: Do not turn the feed lifting cam all the time.

- 6 Set bed cover and gear box lid back to the machine body with screws.

Note: After adjustment, make sure that hook timing, feed lifting cam position and height of feed dog are correctly adjusted.

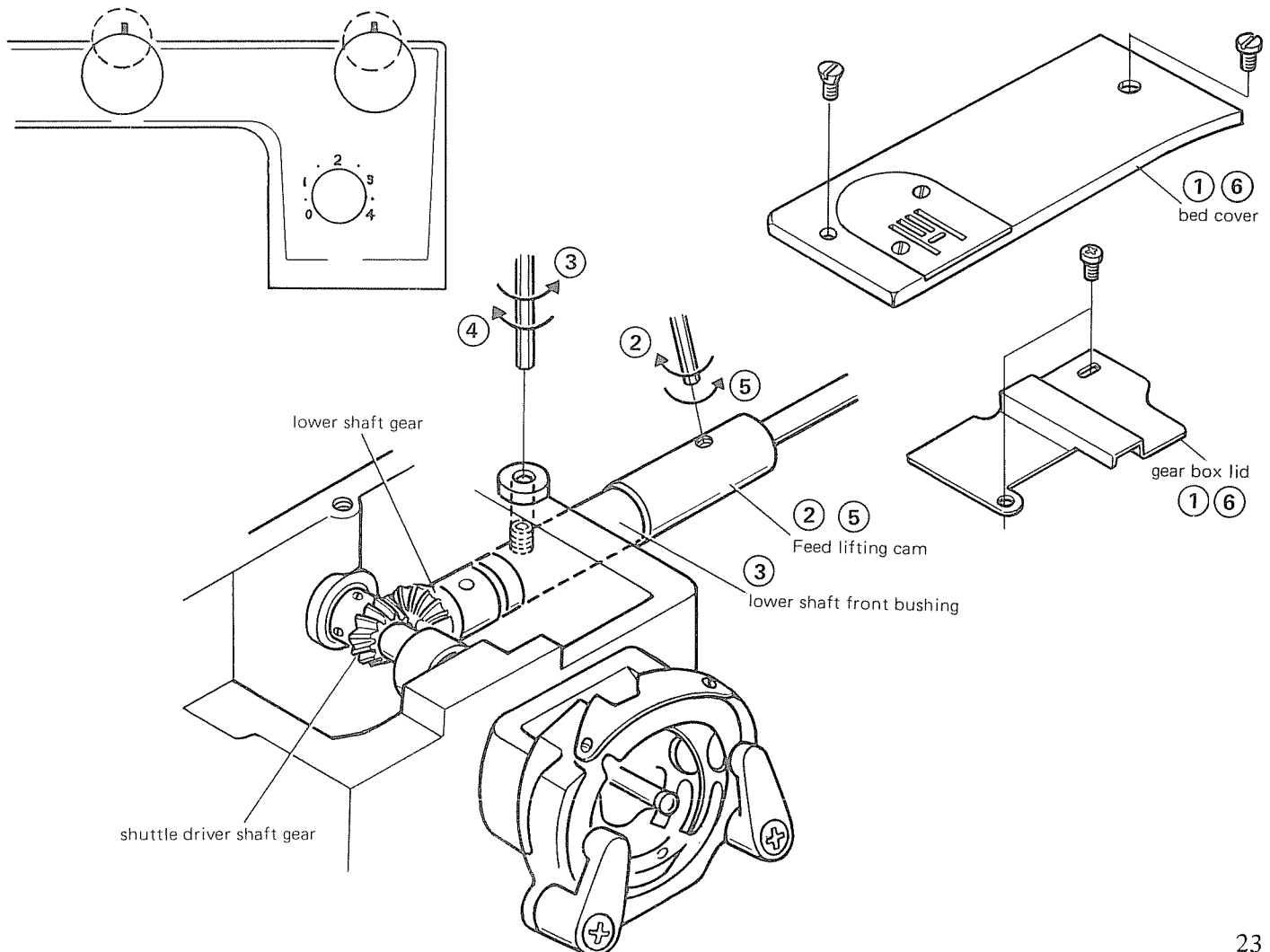

ADJUSTMENT OF FEED LIFTING CAM POSITION

Adjust the feed lifting cam position always after the correct hook timing and clearance between needle and shuttle hook have been obtained.

- 1 Take off bed cover.
- 2 Set pattern selector knob at “ ” and zigzag width regulator knob at “M”.
- 3 Loosen feed lifting cam set screw with hexagon socket wrench.
- 4 While holding the screw with the wrench to prevent turning of feed lifting cam, turn balance wheel toward you until tip of needle comes to the point 4.7mm above from its lowest position.
This position may be alternately indicated that the tip of needle points the same level as inner face of shuttle race ring as illustrated below.
- 5 Tighten the feed lifting cam set screw firmly while adjusting lower shaft thrust play.
- 6 Attach bed cover.

Note: After adjustment, make sure that height of feed dog, pitch difference in feed between forward and reverse stitches and pitch difference in stretch stitch feeding are correct.

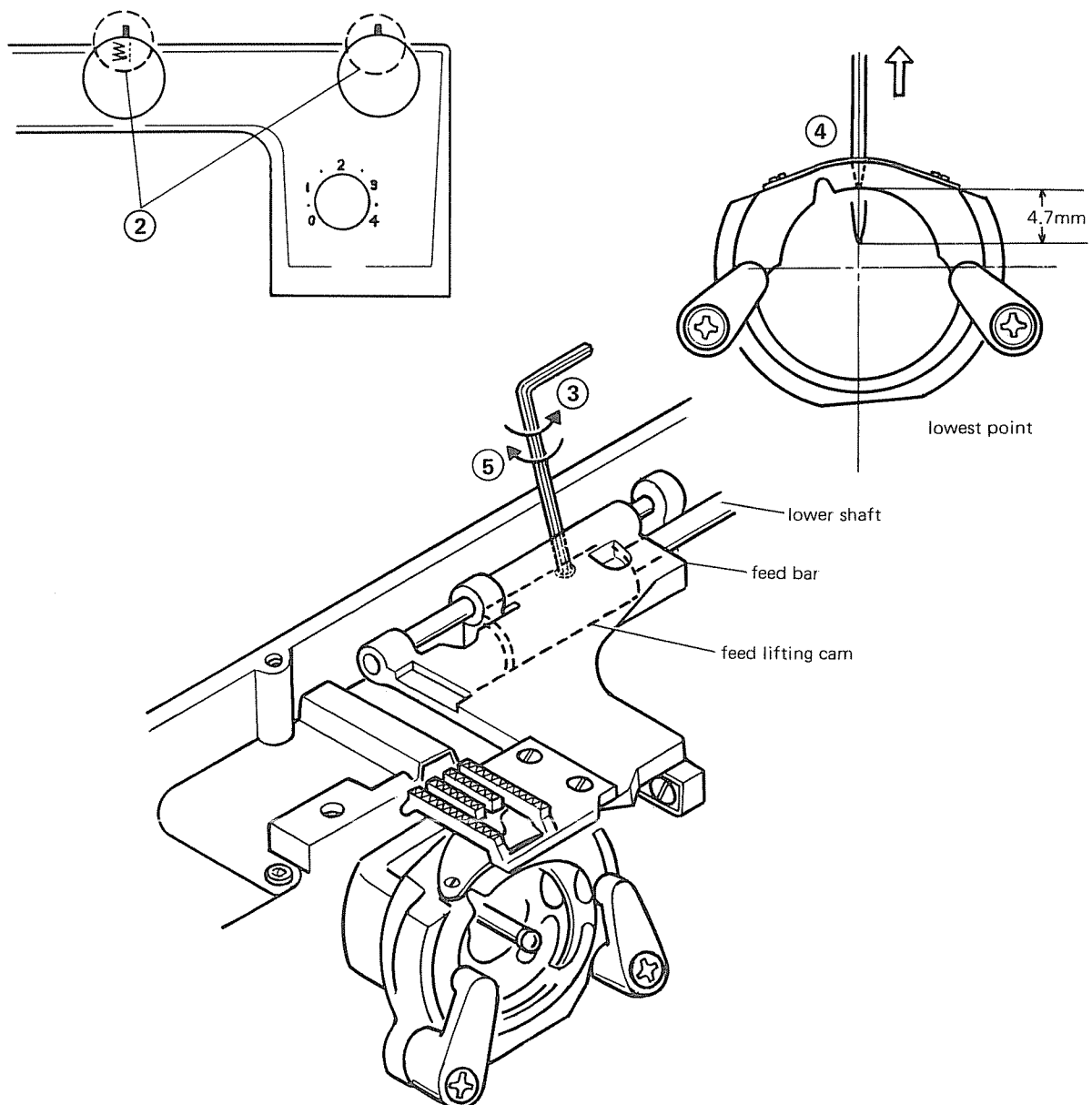

ADJUSTMENT OF HEIGHT OF FEED DOG

Set stitch length regulator knob at “4”, lower presser foot (the pressure regulator should be set at red line) and turn balance wheel toward you until needle bar comes to highest point of its travel. In this condition, height of feed dog above needle plate should be 0.85 ~ 1.0mm (17/512” ~ 3/8”).

When stitch length regulator knob is set at “DOWN”, feed dog should be below top surface of needle plate and should not touch hook race body (unit).

To adjust:

- 1 Set stitch length regulator knob at “4”, (pressure regulator set at red line), turn balance wheel toward you until needle bar comes to highest point of its travel and raise presser foot. Then remove free arm cover.
- 2 Loosen set screw (a).
- 3 Turn feed lifting rock shaft crank roller stud (b) with screw driver to make adjustment.
- 4 Attach free arm cover by tightening free arm cover set screw without fail and lower presser foot. Make sure that correct height of feed dog (0.85 ~ 1.0mm) is obtained. Also make sure that feed dog is below top surface of needle plate and does not touch hook race body (unit) with stitch length regulator knob being set at “DOWN”. Then remove free arm cover again and tighten set screw (a).
- 5 Set stitch length regulator knob at “4” and turn balance wheel toward you until feed dog comes to lowest point of its travel. Loosen set screw (c) and make adjustment that the clearance between feed lifting stopper and bed plate should be 0.2 ~ 0.3mm (5/64” ~ 15/128”). Then tighten set screw (c) and attach free arm cover.

Note: After adjustment, make sure that pitch difference in feed and buttonhole feeding is correct.

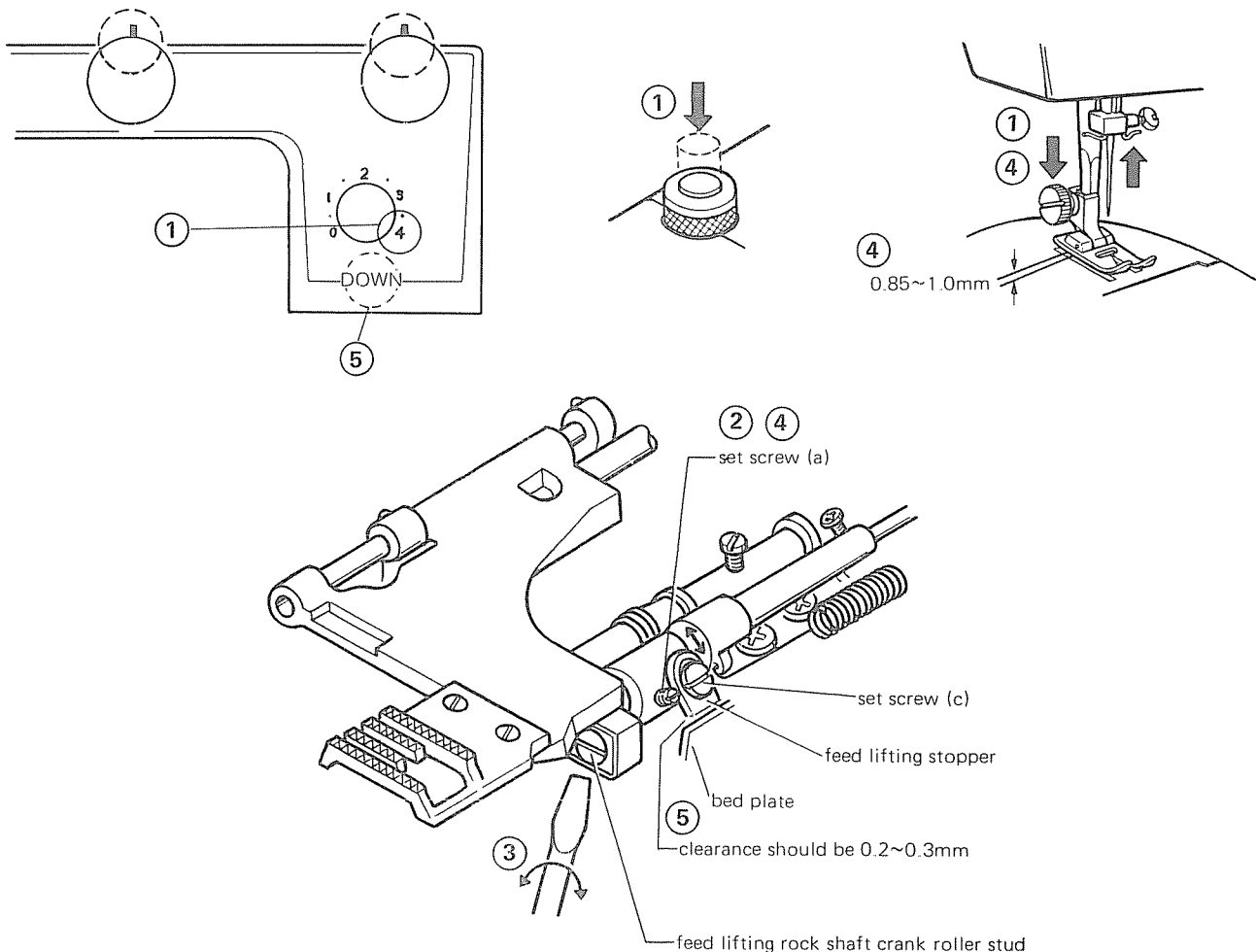

ADJUSTMENT OF PITCH DIFFERENCE IN FEED BETWEEN FORWARD AND REVERSE STITCHES

Count 10 stitches in forward straight stitching. Then, see how many stitches in the same length of reverse straight stitching. The variance of 7.5 to 13.5 stitches in reverse stitching against 10 stitches in forward stitching is considered acceptable for straight sewing. If not, make adjustment as follows:

- 1 Set pattern selector knob at “”, stitch width regulator knob at “M” and stitch length regulator knob at “4”.
 - 2 Loosen nut (c).
 - 3 a) If forward stitches are coarser than reverse stitches, turn screw (d) clockwise (in the direction “A”).
b) If forward stitches are denser than reverse stitches, turn screw (d) anti-clockwise (in the direction “B”).
 - 4 Tighten nut (c) after adjustment.
- *Note: When loosening nut (c) or screw (d), press the reverse push button.

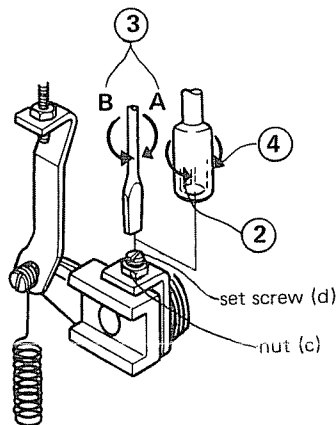
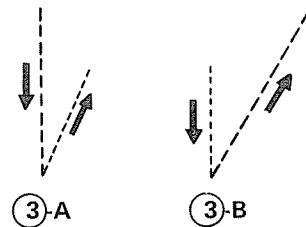
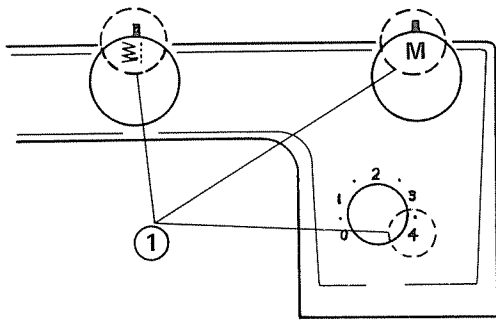

ADJUSTMENT OF PITCH DIFFERENCE IN STRETCH STITCH FEEDING

If there is any pitch difference between back and forward movement in stretch stitch feeding, it may be the cause of deformed patterns. Make adjustment as follows:

- 1 Set stitch length regulator knob at "4", pattern selector knob at "  " and stitch width regulator knob at "M".
- 2 Loosen nut (c).
- 3
 - a) When forward feeding is larger than backward feeding, turn stretch stitch adjusting screw (d) in the direction of (A).
 - b) When forward feeding is smaller than backward feeding, turn stretch stitch adjusting screw (d) in the direction of (B).
- 4 Tighten nut (c) while holding stretch stitch rod lest it should be bent.

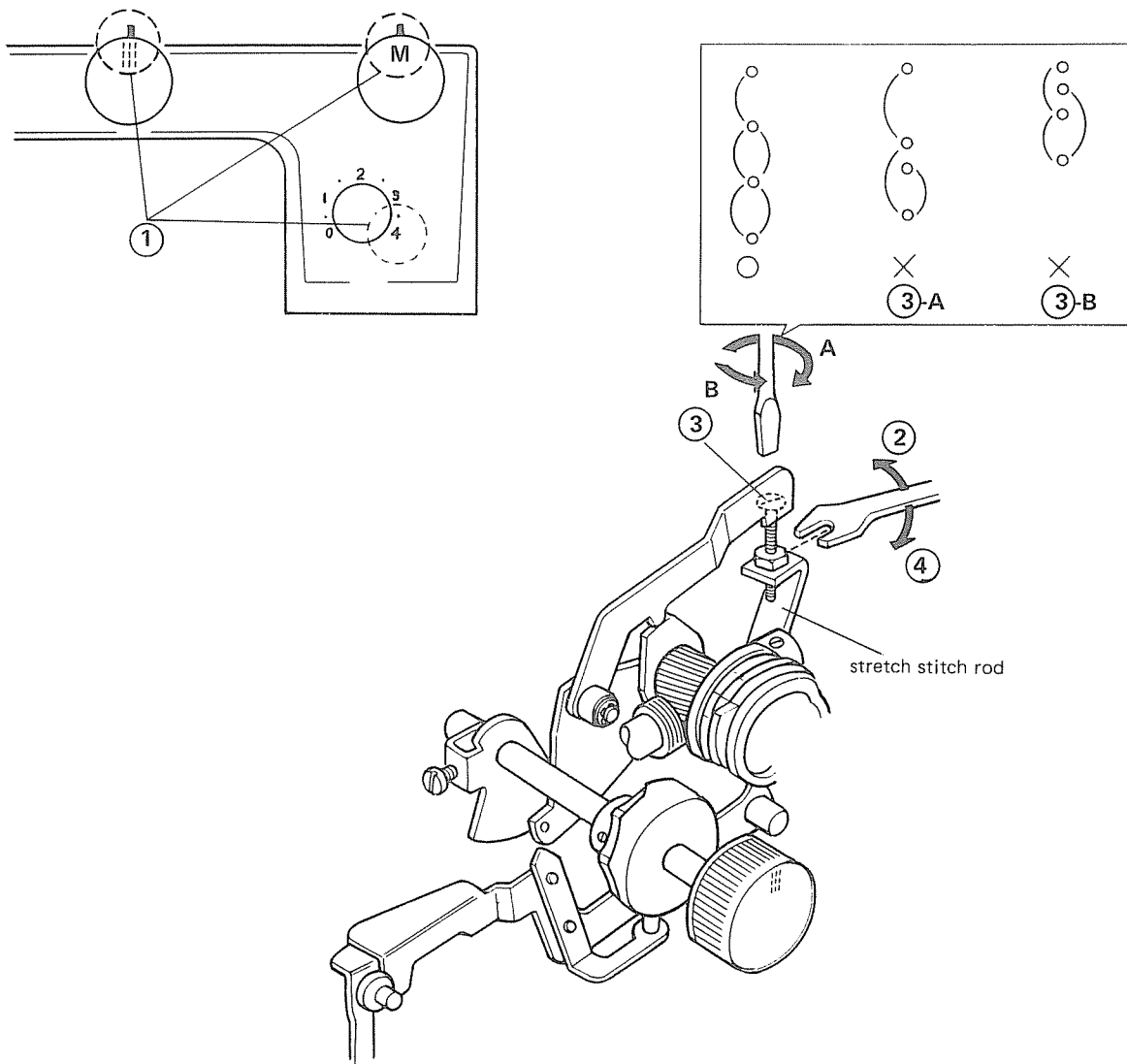

ADJUSTMENT FOR "0" POSITION OF THREAD TENSION

It is the most desirable that the thread can get through without resistance when thread tension regulator dial is set at "0" and a little resistance can be felt when the dial is set at "1".

- 1 Lower presser bar lifter.
- 2 Set thread tension regulator dial at "5" and pull out the knob from the dial unit.
- 3 Loosen the leading screw until the thread can get through between the discs without resistance.
- 4 Set the dial indication "0" on thread tension regulator dial at the scribed line on thread tension bracket and push them as far as it will go.

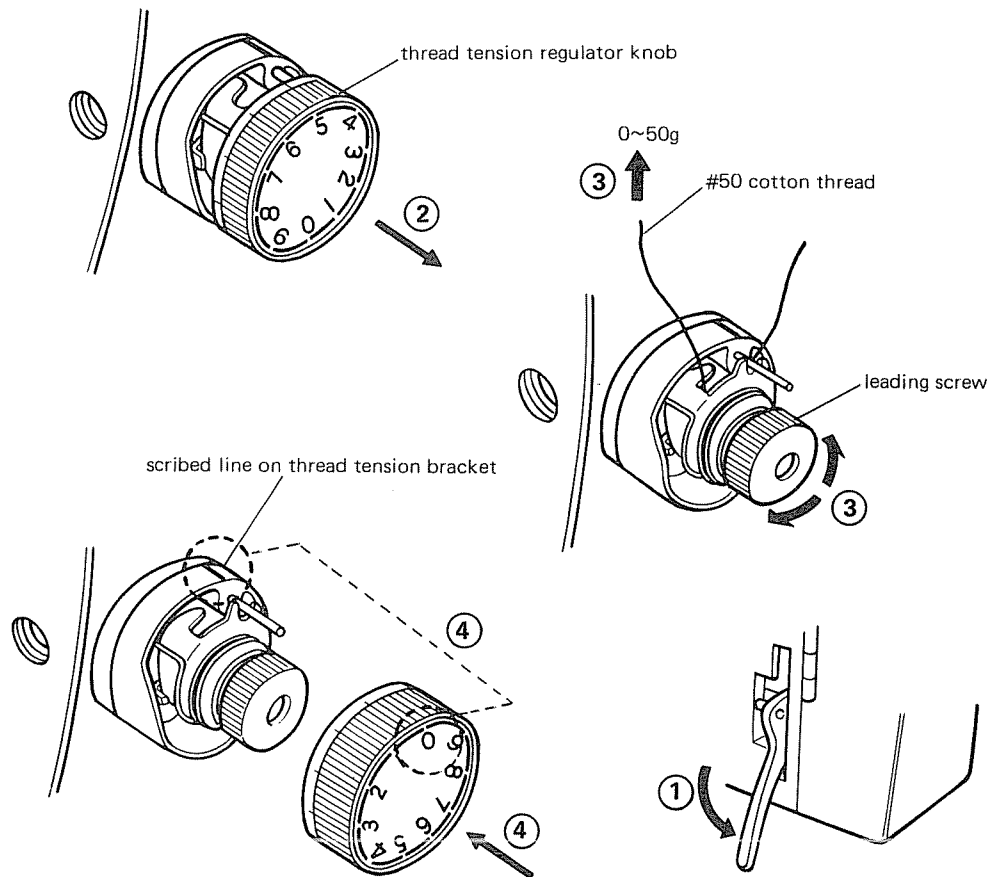

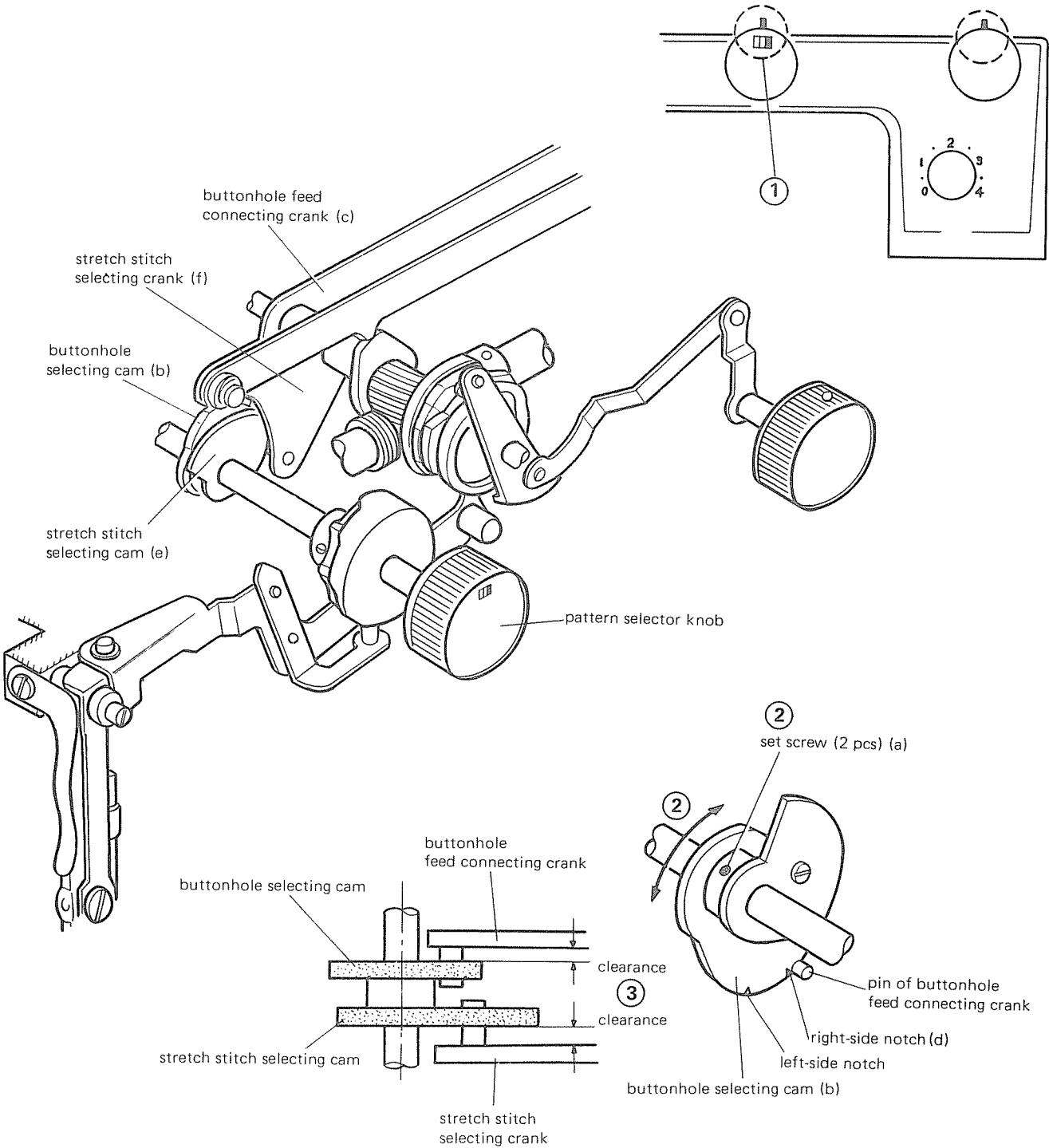

ADJUSTMENT OF BUTTONHOLE SELECTING CAM AND STRETCH STITCH SELECTING CAM POSITIONS

- 1 Set pattern selector knob at “ \sum ”.
- 2 Remove top cover. Then loosen two set screws (a) and turn buttonhole selecting cam (b) to set pin of buttonhole feed connecting crank (c) in the right-side notch (d) of buttonhole selecting cam.
- 3 Make the clearance between buttonhole selecting cam (b) and buttonhole feed connecting crank (c) equal to that between stretch stitch selecting cam (e) and stretch stitch selecting crank (f). Then tighten two set screws firmly.



ADJUSTMENT FOR BAR-TUCK FEED OF BUTTONHOLE

If the fabric is fed with pattern selector knob at “”, make adjustment as follows:

- * The acceptable quantity of bar-tuck feed should be within 1mm for 20 stitches when stitch length regulator is set at “4”.
- 1 Set stitch length regulator knob at “4”, stitch width regulator knob at “5” and pattern selector knob at “” respectively. Then attach buttonhole foot.
 - 2 Remove top cover by loosening set screw.
 - 3 Loosen nut (c).
 - 4 Place a piece of paper under presser foot and turn balance wheel toward you.
 - i) If the paper moves in the direction of “A”, turn buttonhole feed adjusting screw (d) clockwise (in the direction of “A”).
 - ii) If the paper moves in the direction of “B”, turn buttonhole feed adjusting screw (d) anti-clockwise (in the direction of “B”).
 - 5 Tighten nut (c) firmly after adjustment and attach top cover.

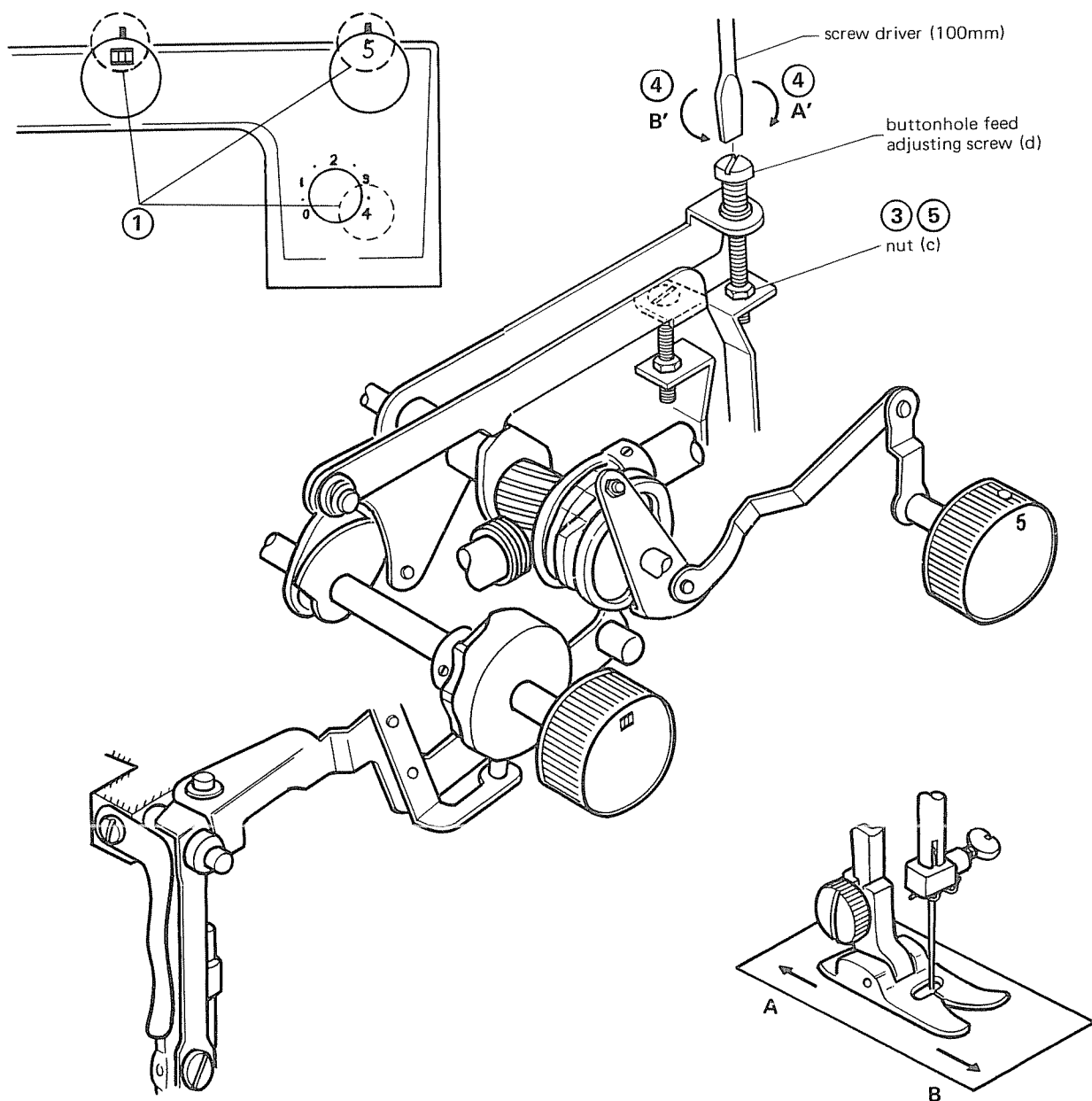

**ADJUSTMENT OF THE DIFFERENCE IN FEED BETWEEN
RIGHT-SIDE ROW AND LEFT-SIDE ROW OF BUTTONHOLE**

Count 10 stitches in the left-side row. Then, see how many stitches in the same length of the right-side row. The variance of 9 to 11 stitches in the right-side row against 10 stitches in the left-side row is acceptable for the buttonhole sewing.

If not make adjustment as follows:

- 1 Set stitch length regulator knob at "0.5" and stitch width regulator knob at "5".
- 2 Turn pattern selector knob in the order of "■" → "■" → "■" → "■", while sewing buttonhole slowly and see any difference between right-side row and left-side row.
- 3 Remove top cover and loosen nut (c).
- 4 If left-side row is coarser than right-side row, turn buttonhole feed adjusting screw (d) clockwise (in the direction of "A").
If the left-side row is denser than right-side row, turn buttonhole feed adjusting screw (d) anti-clockwise (in the direction of "B").
- 5 Tighten nut (c) and attach top cover.

Note: *After adjustment, check the bar-tuck feed.

*When making adjustment, be sure to use the buttonhole foot.

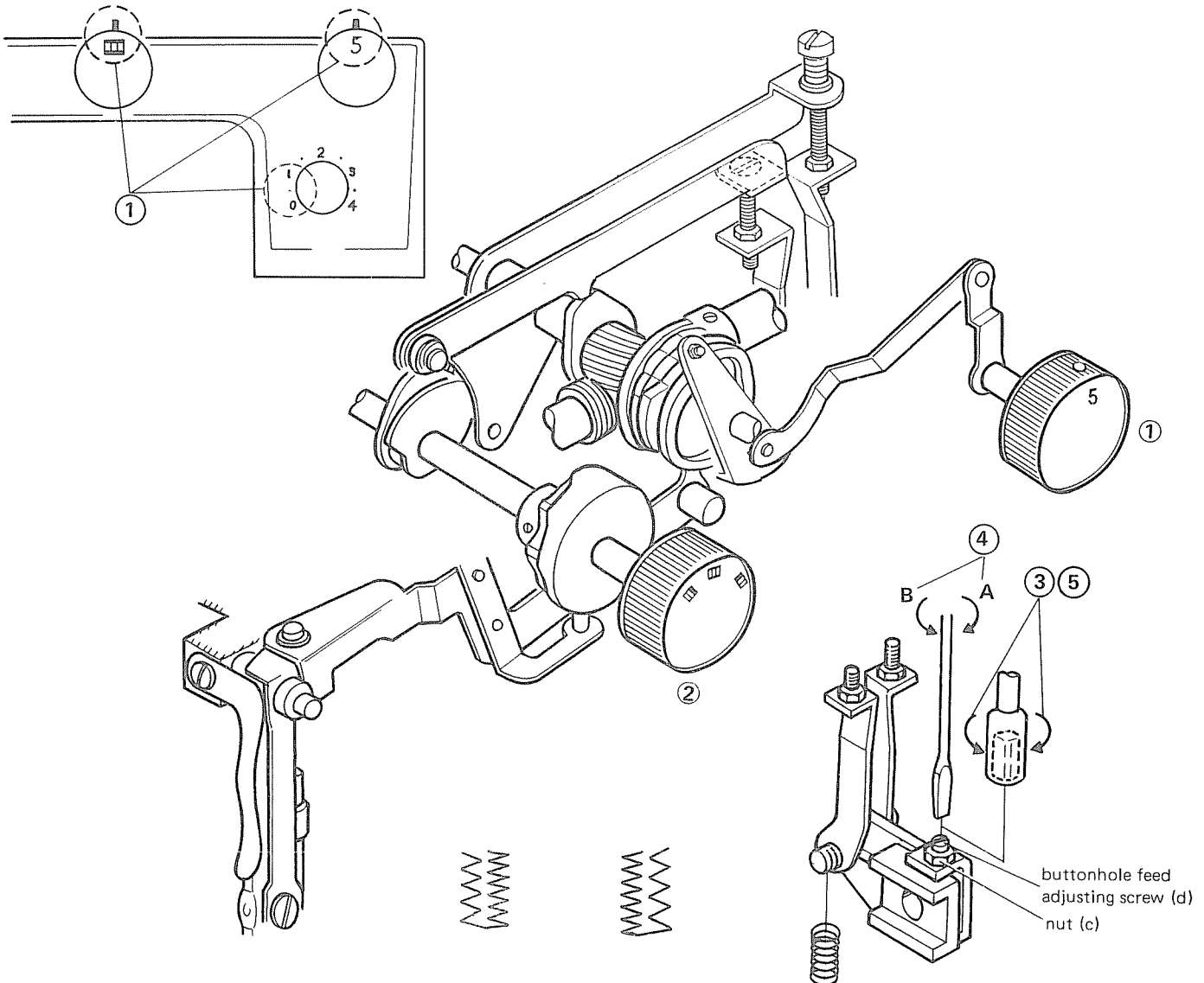

ADJUSTMENT FOR CUTTING SPACE OF BUTTONHOLE

The cutting space of buttonhole should be 0.3 to 0.6mm (3/256" to 3/128"). When the cutting space is too wide or too narrow, make adjustment as follows:

- 1 Set stitch width regulator knob at "5" and stitch length regulator knob at "0.5". Then turn pattern selector knob in the order of "■□" → "□□" → "□■" → "■■" while sewing buttonhole.
- 2 Remove top cover and loosen set screw (c).
 - a) If the cutting space is too wide, move stitch width regulating crank (d) in the direction of "A".
 - b) If the cutting space is too narrow, move stitch width regulating crank (d) in the direction of "B".
- 3 Tighten set screw (c) temporarily.
- 4 Test sew buttonhole and check the cutting space. Then tighten set screw (c) firmly after the correct cutting space is obtained.

Note: *When make adjustment, use the buttonhole foot.

