



HERE'S HOW TO USE  
YOUR STREAMLINED

**Bell & Howel**

TRADE MARK

**SEWING MACHINE**



Guaranteed for  
Years

**25**

**MODEL 620**

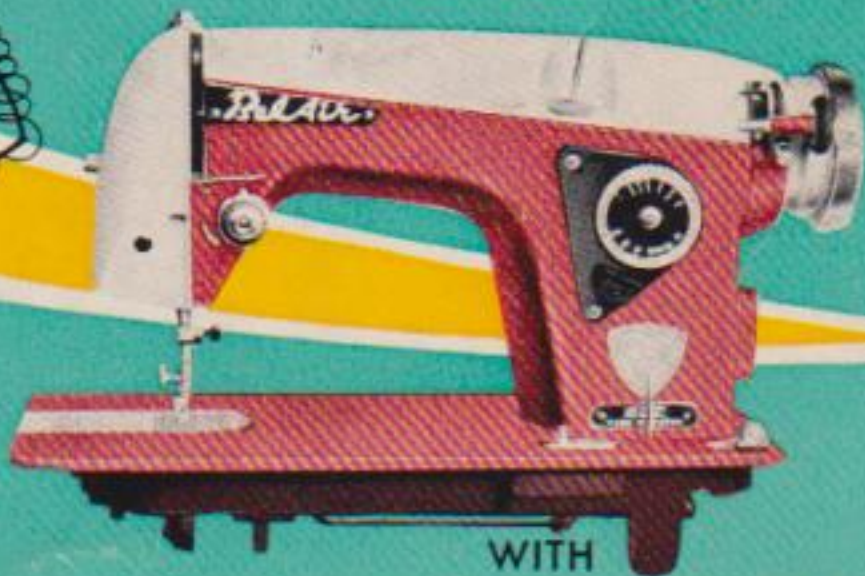

WITH  
BUILT-IN SEWLIGHT

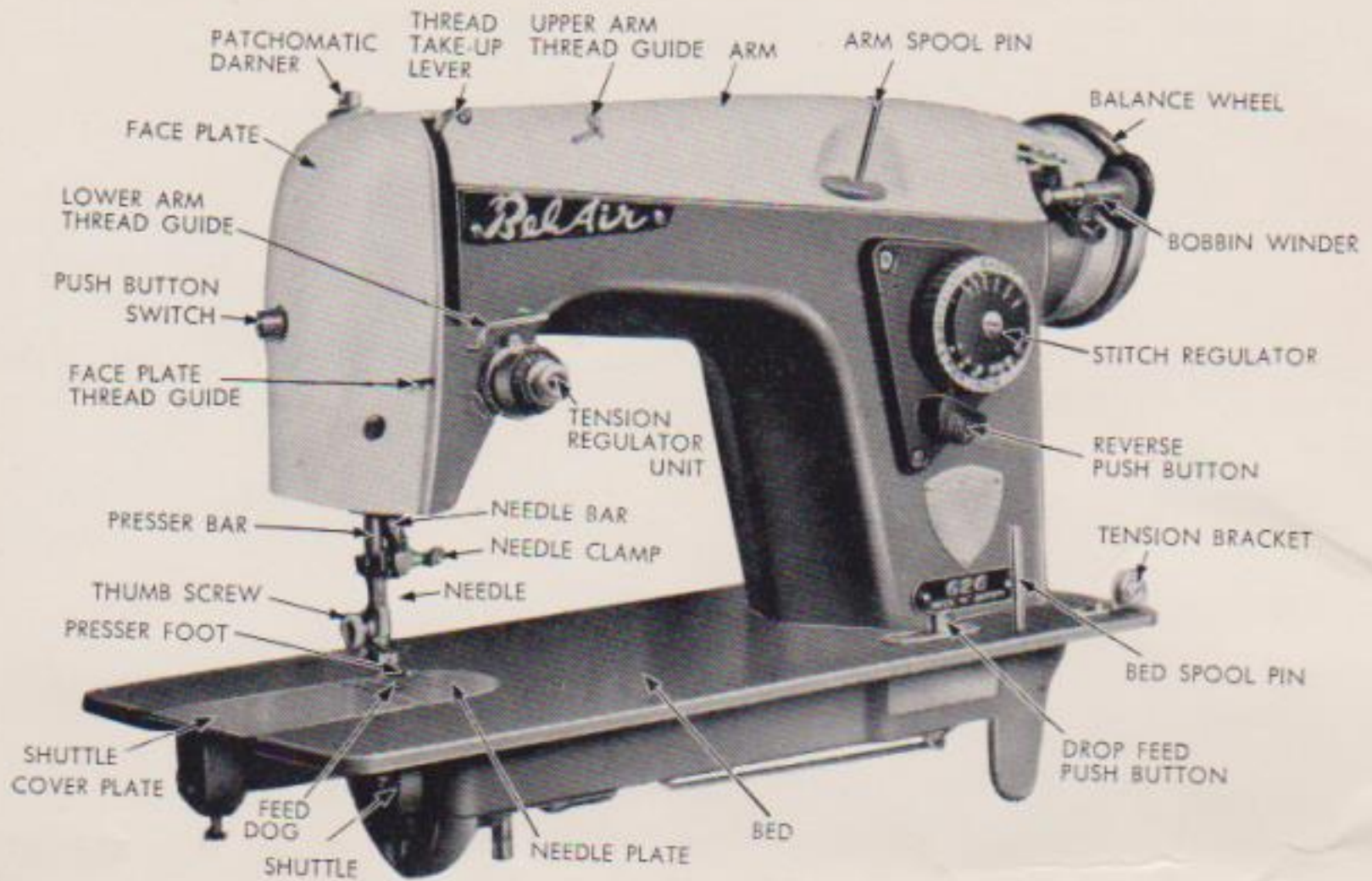

**FACTORY SUGGESTED  
 LIST PRICE  
 FOR PORTABLE UNIT  
 \$ 219.50**



. . . welcome to the growing family of happy owners of this fine, precision-built electric sewing machine.

You now have one of the finest full-size sewing machines made, with all these wonderful features :

*Welcome*

- Automatic push button bobbin winder.
- Built-in darning.
- Forward and reverse stitch.
- Thread cutter on foot bar.
- Metal box of accessories.

- Built-in sewlight.
- Hinged shuttle cover plate.
- Race is removable by simply turning two pivoted clasps.
- Shut-L-Kleen for prevention of jamming of the shuttle race.
- Hinged race ring prevents loss or damage.
- Shuttle driver is lined with a spring to reduce noise.
- Front link take-up. This causes the machine to run quieter and smoother and with less wear on the parts. It also makes it easier to thread the machine.
- Numbered tension dial located in the front in a harmonizing color. This makes it easier to set the tension and easier to thread the machine.
- Drop feed push button on machine base.
- Needle bar bushing.
- The sewing parts and bulbs are interchangeable with standard makes.
- Uses standard attachments and buttonholers.

This machine is precision-built for a lifetime of sewing pleasure. It will require a minimum amount of servicing, and will give the maximum in satisfaction. Needles, bobbins and other parts are interchangeable with those of other first class manufacturers.

This manual provides all the information needed to operate the machine and to care for it properly. Hence, read through the book thoroughly so that you may become familiar with behavior and operation of the machine. Follow all instructions closely.

## BALANCE WHEEL STOP MOTION

Hold the balance wheel with the left hand, and with the right hand turn the stop motion screw towards you as indicated by arrow in Fig. 2.

This will allow the balance wheel to revolve freely without operating the stitching mechanism.



Figure 2

## TO INSERT THE NEEDLE

Raise the needle bar (Fig. 3) to the highest position by turning the balance wheel towards you with your right hand.

Loosen the needle clamp screw at the lower end of needle bar and push the thick end of the needle with the flat side to the right into the slot of the needle bar.

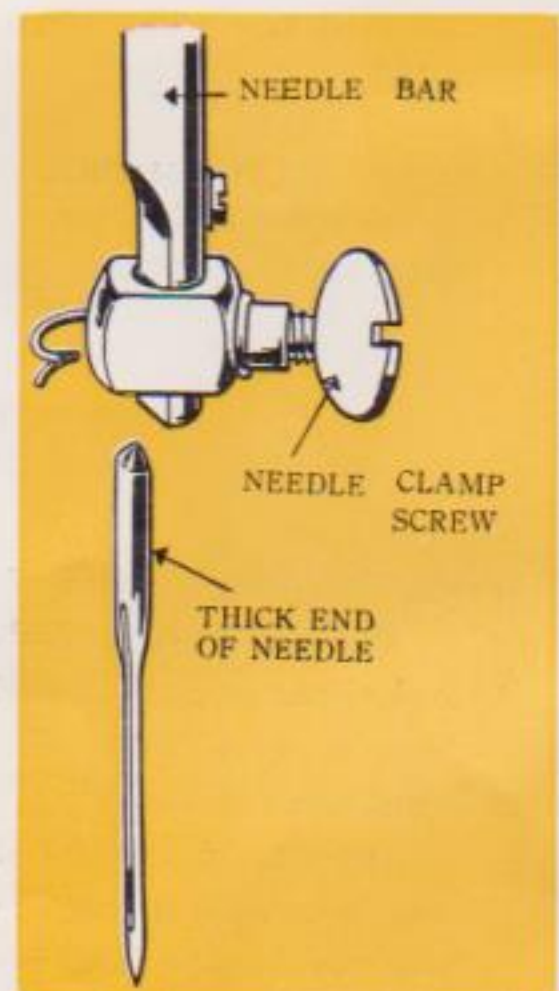

Figure 3

Insert the needle as far as it will go until it touches the pin which is visible in the slot above the needle clamp; then tighten the needle clamp screw firmly.

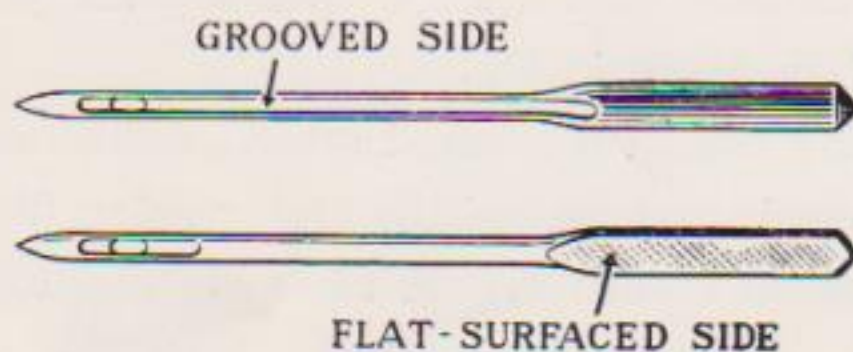

Figure 4

### ***TO THREAD THE NEEDLE***

Raise the take-up lever (E) to its highest point by turning the balance wheel towards you.

Place a spool of thread on the spool pin on the front of the machine arm. Pass the thread through the upper arm thread guide (A), through the lower arm thread guide (B) downwards around the tension discs from right to left, up over the tension thread guard (C) from behind, down into the loop of the take-up spring (D), up and through the hole in the end of the take-up lever (E), down through the lower face plate thread guide (F) and into the thread guide (G) at the lower end of the needle bar. Then pass from left to right through the eye of the needle (H). Draw about two inches of thread through the eye of the needle with which to commence sewing.

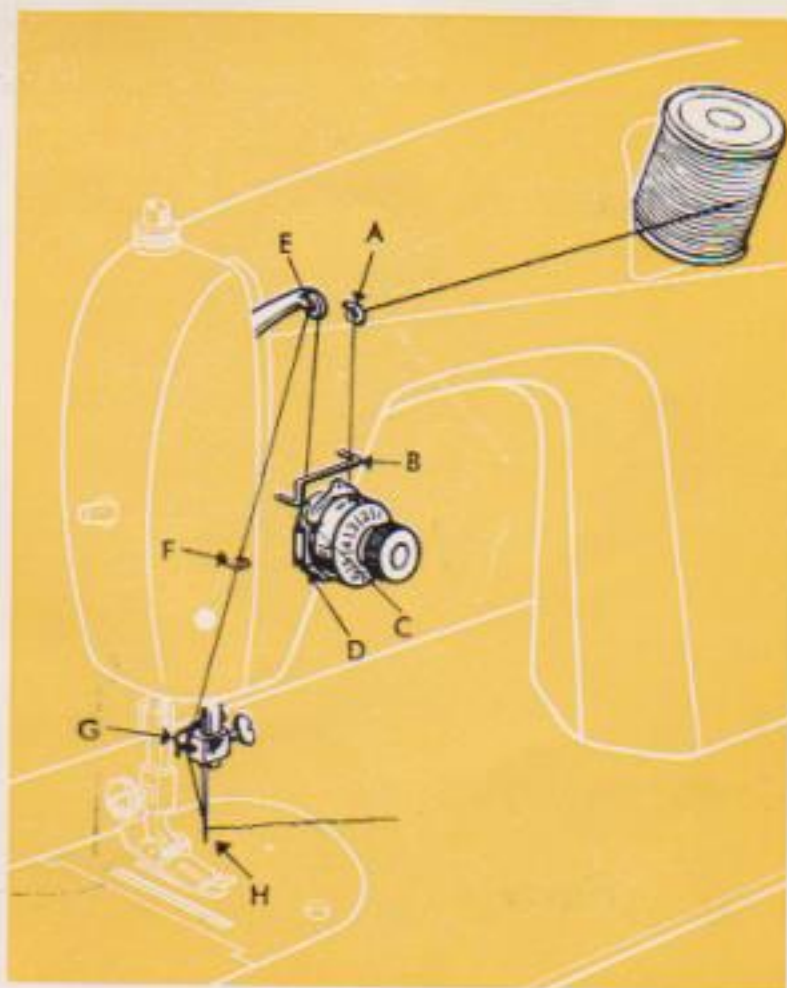

Figure 5

## TO WIND THE BOBBIN

Disconnect the balance wheel by holding it in the left hand, while turning the stop motion screw over towards you with the right hand as shown in Fig. 2.

Wind the free end of the thread several times round the bobbin and press it onto the spindle (A), passing the thread through the tension bracket (B) as shown in Fig. 6.

Press the push-button (C) until the latch fits securely into the bobbin. When the bobbin is filled, the latch automatically disengages and stops the winding operation.

By using the spool pin on the machine bed, spare bobbins can be wound without interfering with your sewing.

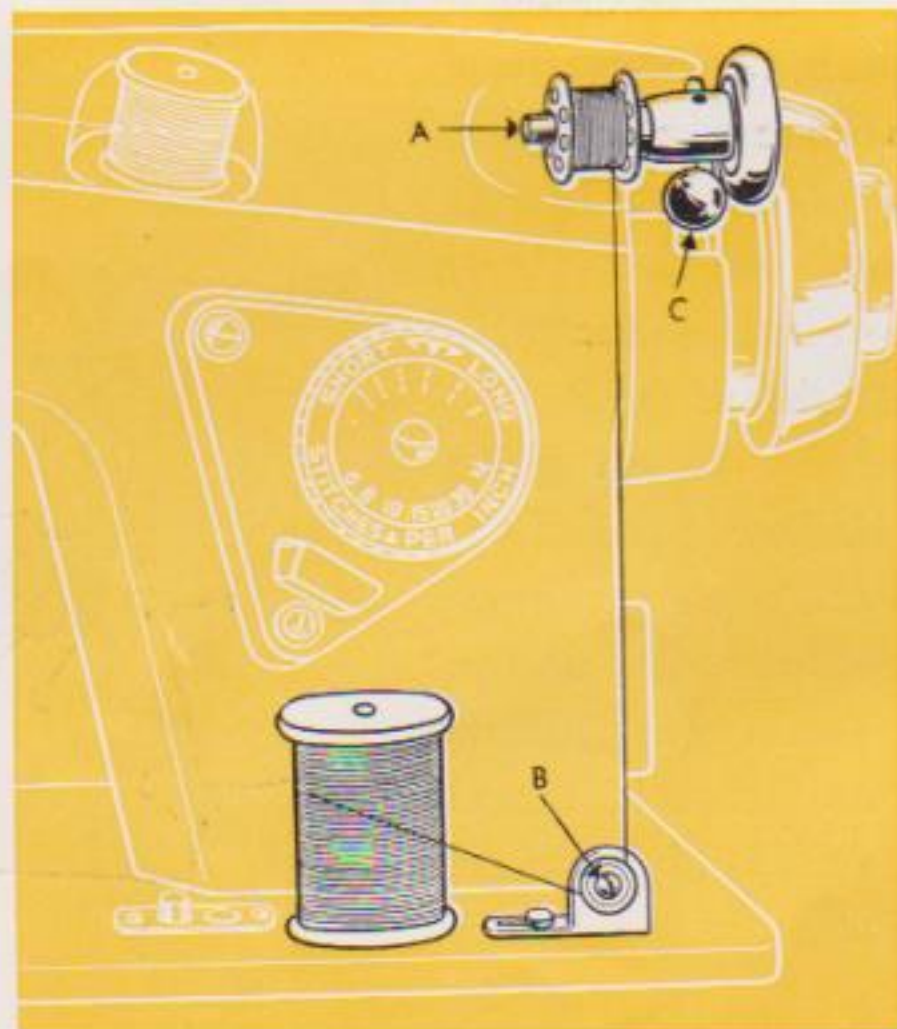

Figure 6

## TO THREAD THE BOBBIN CASE

Hold the bobbin between the thumb and forefinger of your right hand and pull out a length of two or three inches of thread (see Fig. 7).

Holding the bobbin case in your left hand, turn the open side up and place the threaded bobbin into it.

With the right hand guide the thread into the slot in the edge of the bobbin case (see Fig. 8).

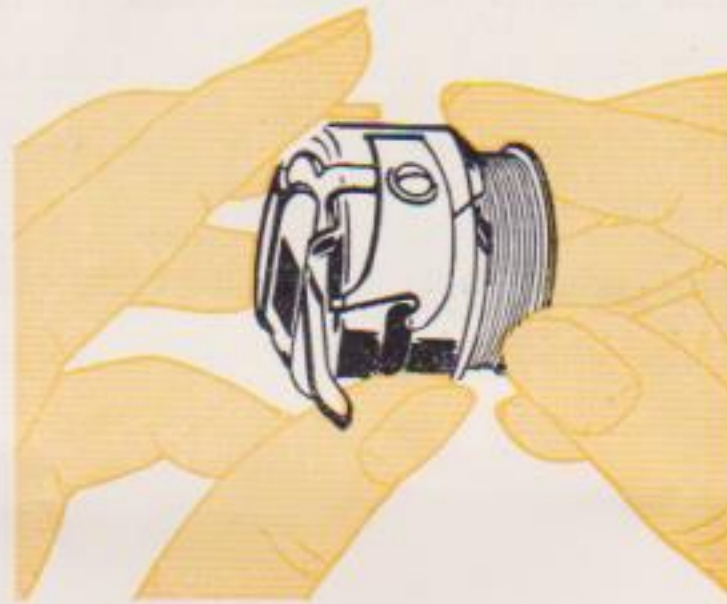

Figure 7

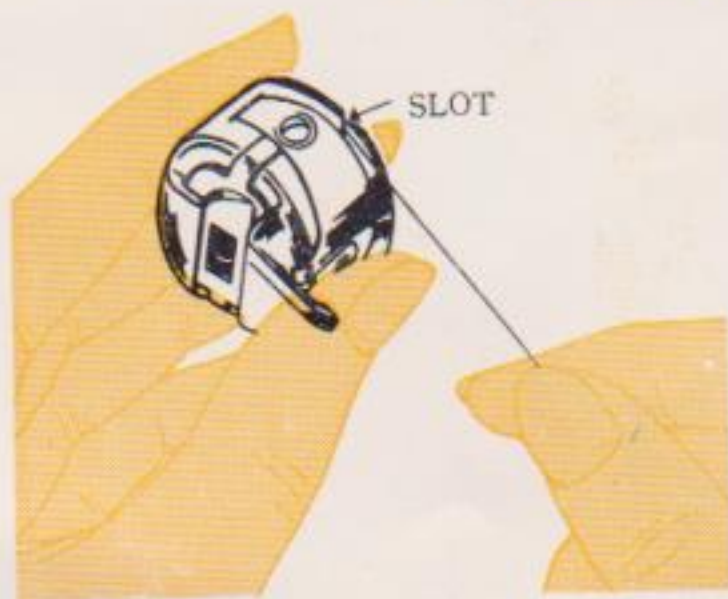

Figure 8

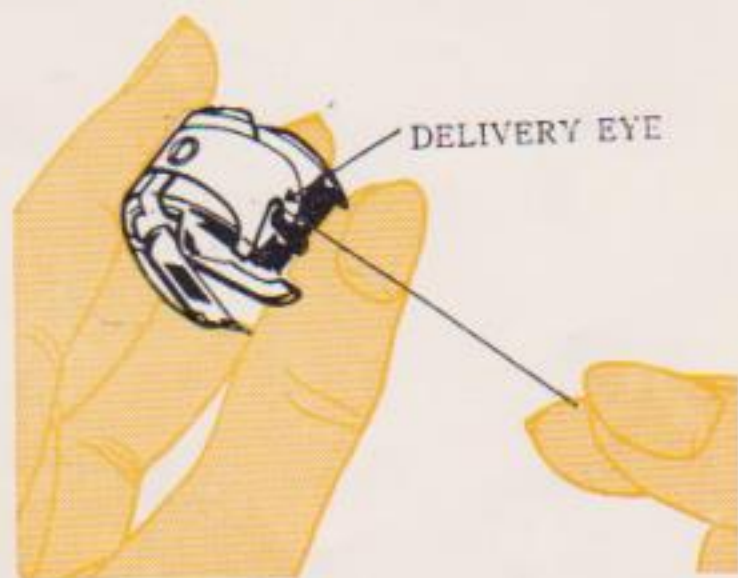

Figure 9

Then pull the thread to the right, under the tension spring and into the delivery eye (see Fig. 9).

In order to keep the bobbin from dropping out of the case when it is turned with the open side down, always keep the hinged latch on the front of the bobbin case open.



## ***TO TAKE OUT THE BOBBIN AND BOBBIN CASE***

Turn the balance wheel towards you until the needle bar is at its highest point, flip open the shuttle cover plate in the bed of the machine so that the bobbin case (see Fig. 10) can be reached. Insert the thumb and forefinger to open the latch and withdraw the bobbin case.

While the latch is held open, the bobbin is retained in the bobbin case and will not drop out. On releasing the latch and turning the bobbin case downward, the bobbin will drop out.

The bobbin case must never be removed when the needle bar is in the lowest position, as this is liable to damage the bobbin case or the shuttle.

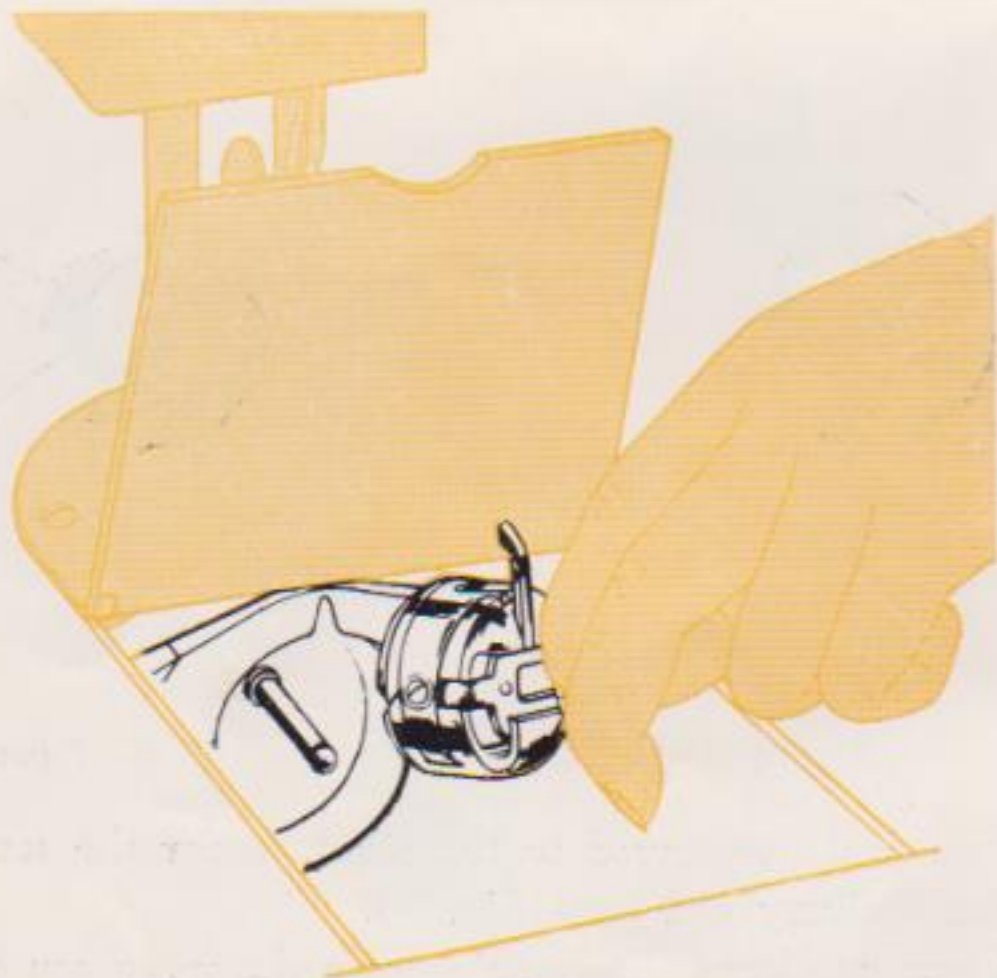

**Figure 10**

## TO OPEN THE SHUTTLE RACE

Because your machine is specially equipped with the exclusive patented Shut-L-Kleen which prevents jamming of the shuttle, it will rarely be necessary to open and clean the shuttle-race.

However, if for some reason it should ever be required to open and clean the shuttle-race, its design enables you to do this most easily and conveniently without sacrificing the precise fit which is so essential to the efficient working of the machine.

To open the shuttle-race, first raise the needle bar to its highest point and remove the bobbin case.

Next, twist the shuttle-race ring clasps downward (Fig. 11).

The shuttle-race ring will then swing down on its hinge enabling you to remove the shuttle. Carefully remove shuttle and clean out shuttle-race. Replace shuttle, shuttle-race ring and lock with clasps. Be careful not to drop or otherwise damage the shuttle.

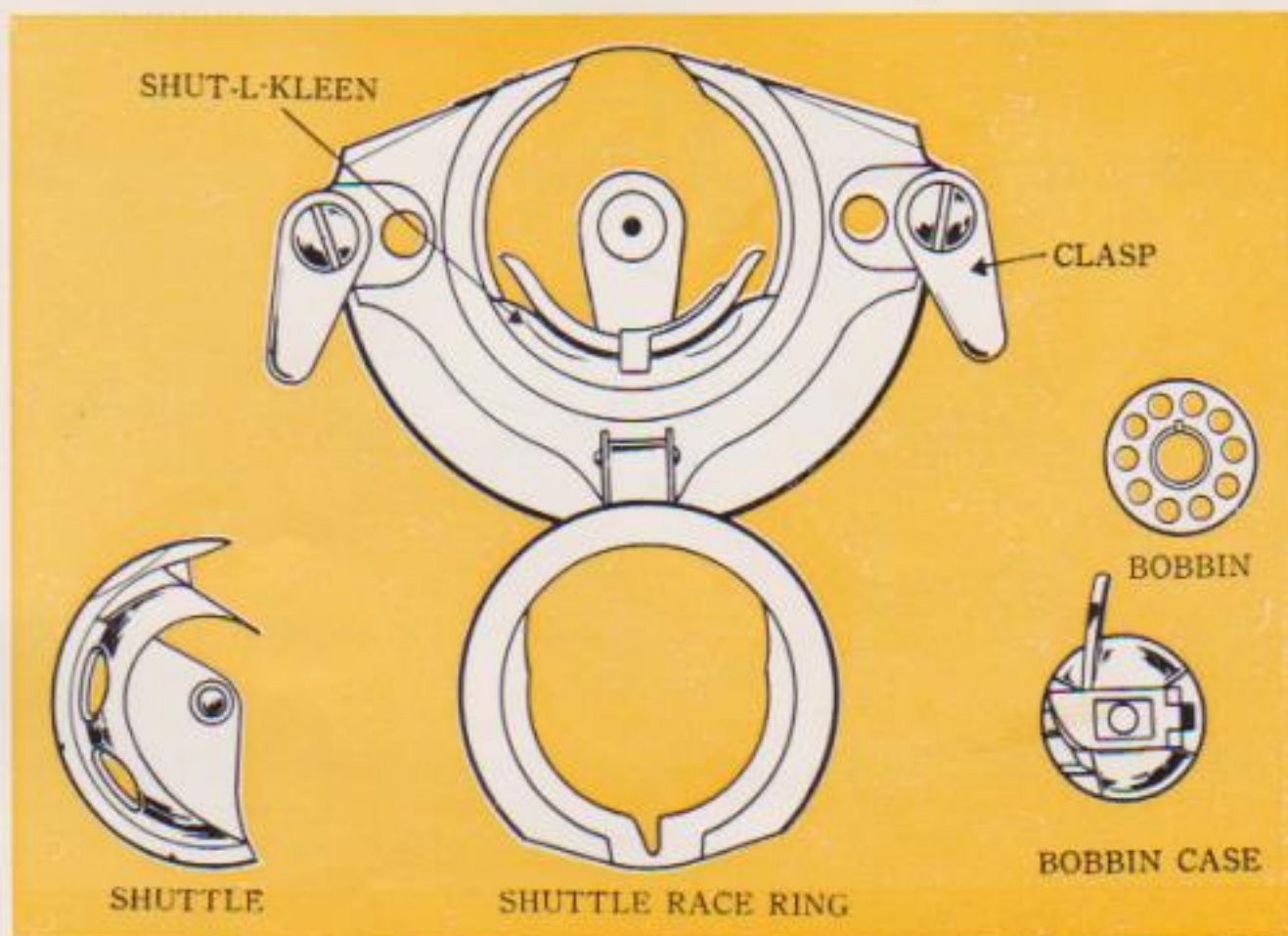

Figure 11

## TO COMMENCE SEWING

Hold needle (upper) thread loosely with your left hand.

Turn the balance wheel towards you with the right hand until the needle moves down and up again to its highest point, thus catching the lower (bobbin) thread.

Now pull the end of the upper thread you are holding and the bobbin thread will be brought up with it through the needle hole in the needle plate, as shown in Fig. 12. Place both ends of thread back under the presser foot.

Place the fabric to be sewn beneath the presser foot, lower the foot upon it and then start the machine according to the directions already given.

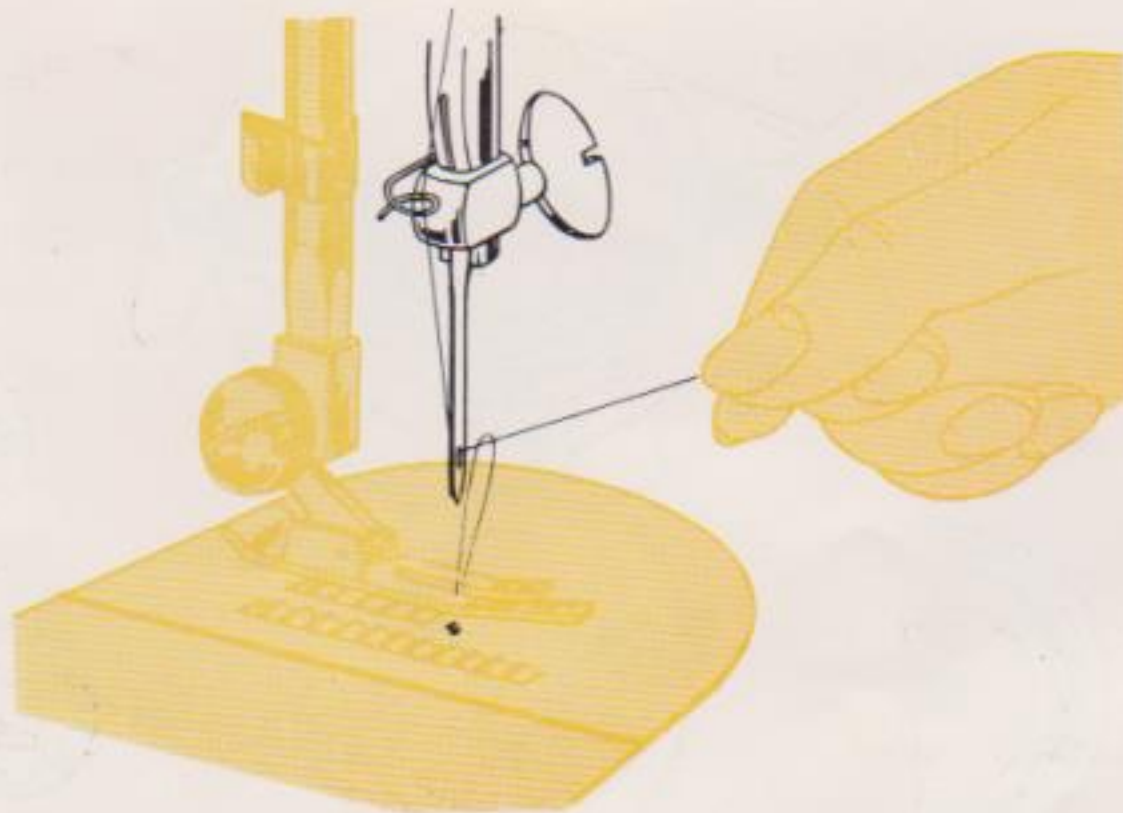
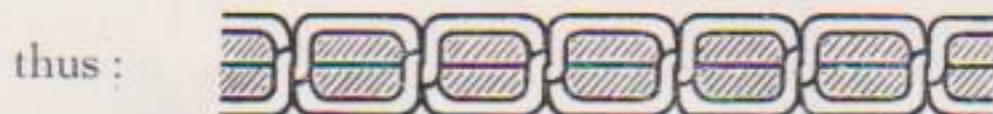

Figure 12

## *TO REGULATE THE TENSIONS*

For ordinary stitching the tension of the upper and lower threads should be equal so as to lock both threads in the center of the fabric,



If the tension of one thread is stronger than of the other, imperfect stitching will be the result. If the tension of the upper thread is greater than that of the lower thread, it will lie straight along the upper surface of the fabric,



If the tension of the lower thread is greater than that of the upper thread, the lower thread will lie straight along the underside of the fabric,



### *1. TENSION OF THE UPPER THREAD*

The sewing machine will give perfect performance when the upper-thread tension is correctly adjusted.

A) The tension on the upper thread will become stronger when the tension-dial knob is turned in the direction marked (+).

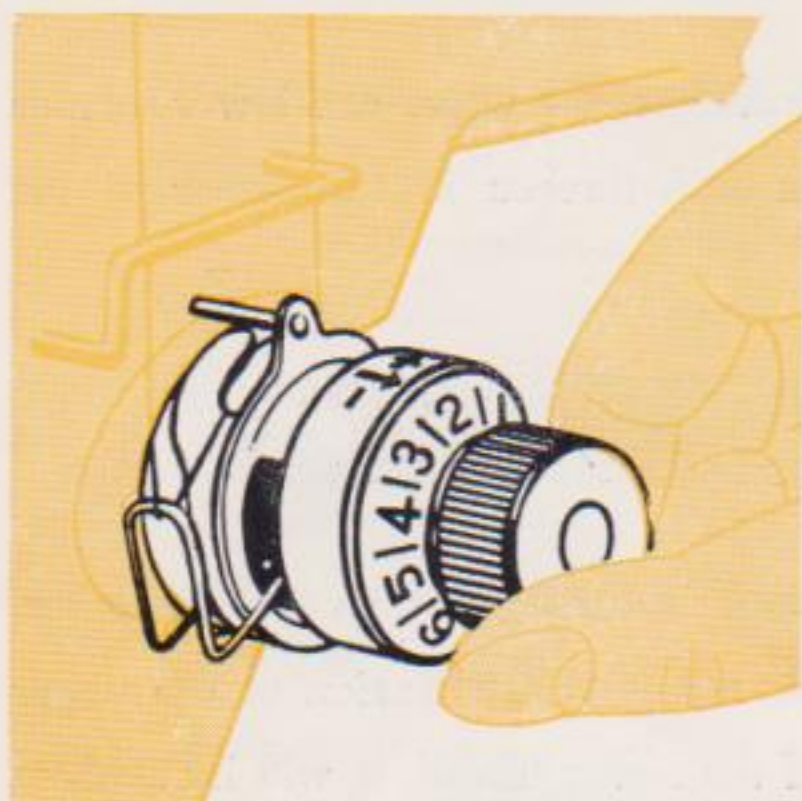

Figure 13

- B) Contrariwise, the upper thread tension becomes weaker when the tension dial knob is turned in the direction marked (-).
- C) Once the tension has been adjusted satisfactorily, the dial can be returned to the same dial-number to obtain the same results.

## 2. TENSION OF THE LOWER THREAD

The tension of the lower thread is regulated by the screw on the bobbin case tension spring (see Fig. 14).

Use the small driver to tighten the screw slightly to increase the tension, or loosen it to slacken the tension.



Figure 14

## TO REGULATE THE LENGTH OF STITCH AND THE DIRECTION OF FEED

### 1. ORDINARY STITCHING

Turn the stitch regulator dial to the required stitch length, as shown in Fig. 15.

### 2. REVERSE STITCHING

For reverse stitching, first adjust the stitch regulator dial to obtain the desired stitch length as explained above and then push in the reverse push button as far as it will go. Machine will sew in reverse as long as the reverse push button is held in.

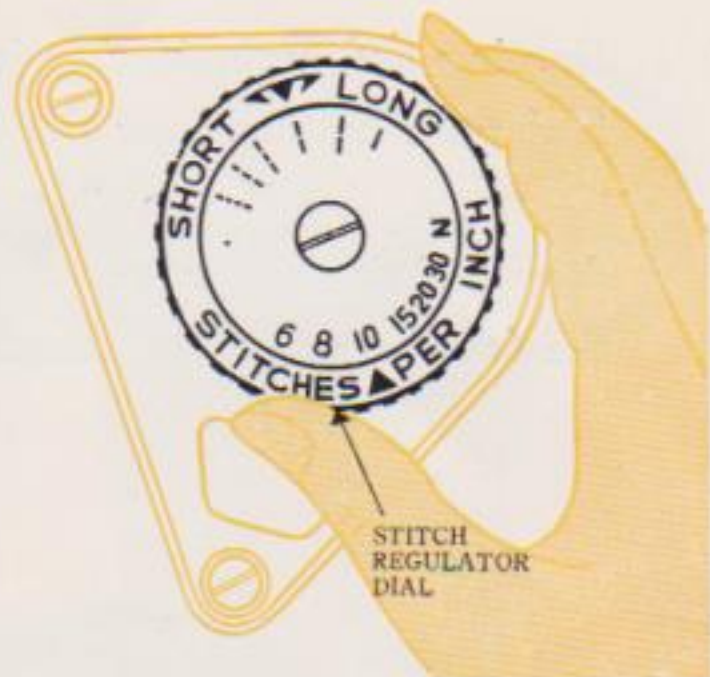

Figure 15

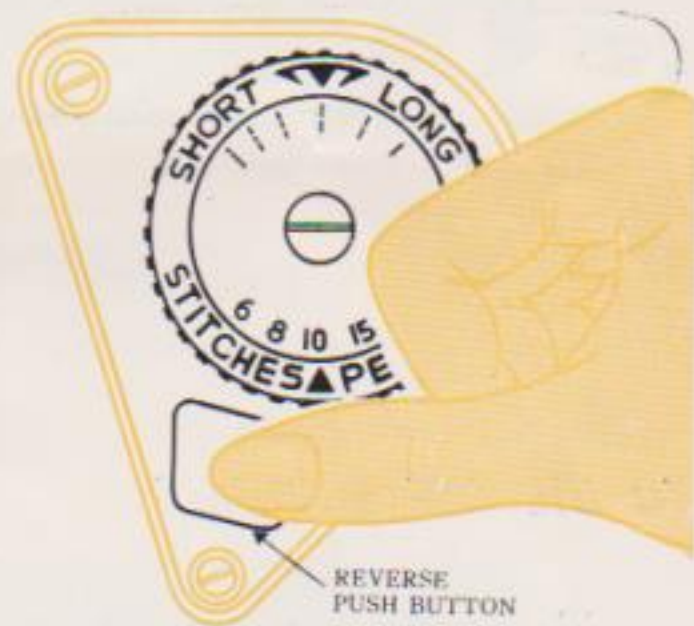

Figure 16

## TO REMOVE THE WORK

Raise the needle bar to its highest point; lift the presser foot and draw the fabric rearward and to the left and sever the threads by passing them over the thread cutter above the presser foot (see Fig. 12). Cut the ends of the threads a few inches long from the needle.

## *TO USE THE DROP-FEED DEVICE*

Darning and embroidering is facilitated by means of the drop-feed push buttons near the right-hand corner of the bed.

When the button "darn" is pressed down, the feed dog drops below the surface of the needle plate. This will permit the free movement of the cloth.

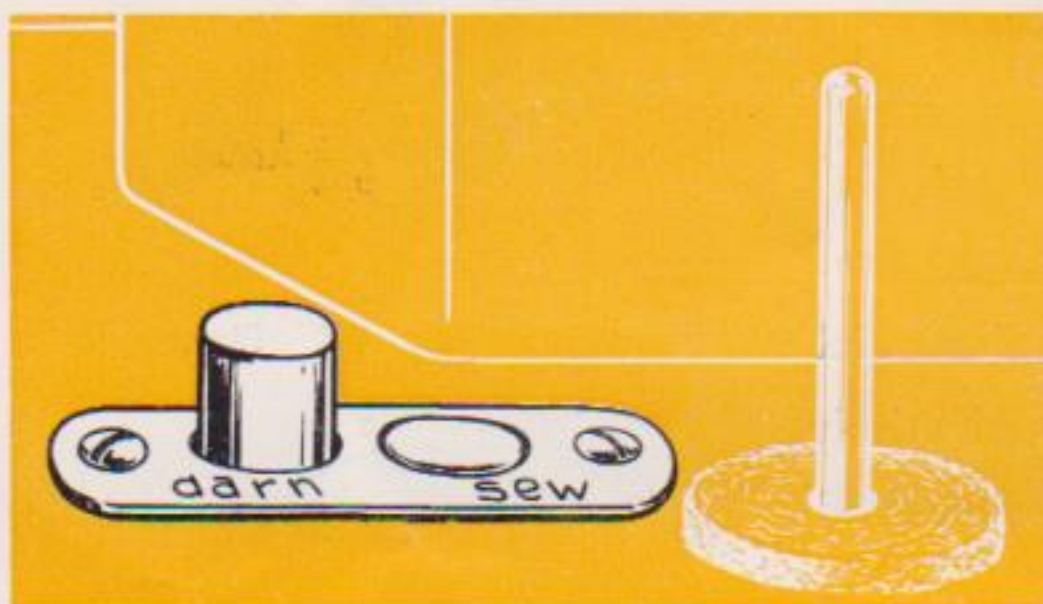

The feed dog will immediately return and resume its normal operation when the button "sew" is pressed down (see Fig. 17).

Figure 17

## *TO OIL THE MACHINE*

To insure easy and free working of the machine it is necessary that all moving parts be covered with a film of oil and not be allowed to become dry. The shuttle-race should also be oiled on occasion.

The machine should be oiled at the places, indicated by arrows in the Figs. 18-19. To avoid soiling of the material apply only a few drops of oil at each oil hole.

After oiling, run the machine rapidly for a few minutes to work the oil into the bearings. When in constant use the machine should be oiled two or three times a week.



Figure 18

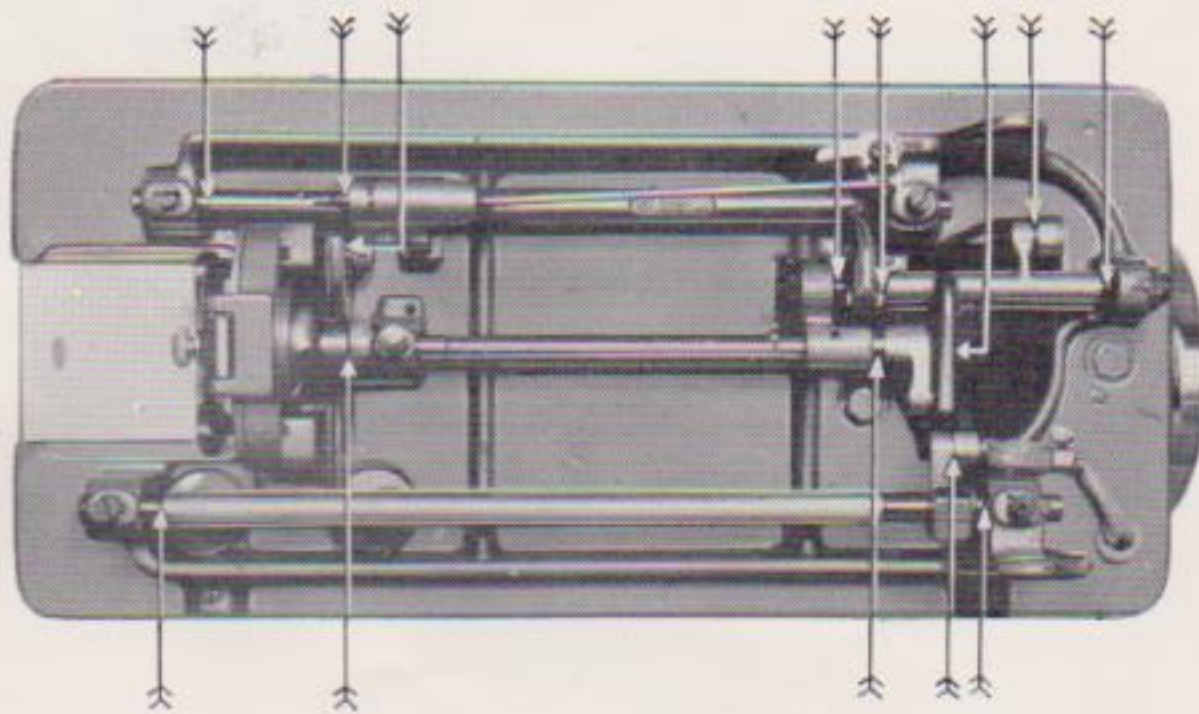

Figure 19



## TO USE THE BUILT-IN SEWLIGHT

To insert the electric bulb, first loosen the face plate screw and remove the face plate. Then the bulb can be easily exchanged.

The light is turned on and off by means of the push button switch found on the face plate.

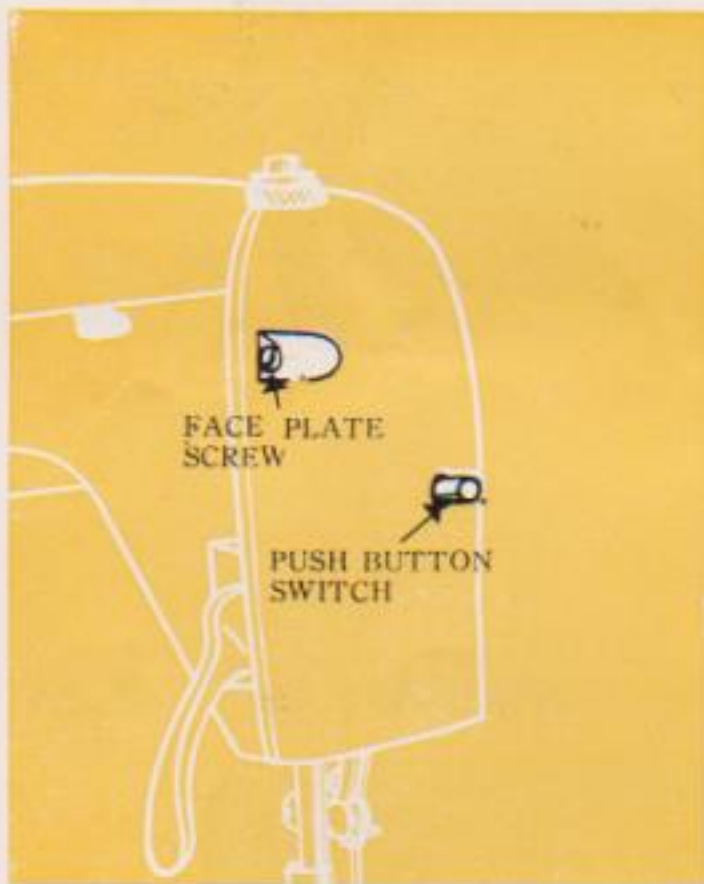

Figure 20

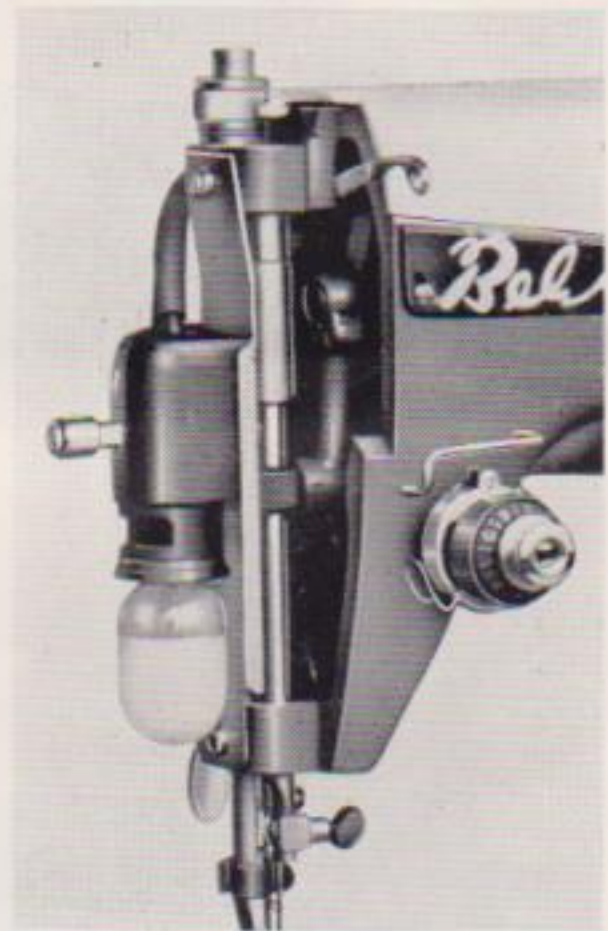

Figure 21

## **USEFUL HINTS**

**Machine Working Heavily.** If the machine works hard after standing for some time, apply a little kerosene in place of oil. Then run the machine rapidly to clean the bearings, then oil with sewing machine oil. The use of inferior oil is usually the cause of the machine working heavily.

**Thread Breaking.** If the needle thread breaks, it is probably due to one of the following causes.

The machine is improperly threaded.

The tensions are too tight.

The needle is bent or has a blunt point.

The thread is too coarse for the size of the needle.

(see page 16).

The thread take-up spring (see D., Fig 5) is broken.

If the lower thread breaks, adjust the bobbin case tension (see page 10); also see that the inside of the bobbin case and the underside of the bobbin case tension spring are free from lint.

**Skip Stitches.** A bent or blunt pointed needle is often the cause of this. See that the needle is accurately inserted (see page 2). Remove the needle plate and, after ascertaining that the feed dog is clean and working freely, replace the needle plate.

**Needle Breaking.** See that the needle is not bent and avoid pulling the material when stitching; either will cause the needle to strike the needle plate and break.

**Material Puckering.** This is generally due to incorrect tension. See that both the bobbin case and the needle are properly threaded; that the thread used is of good quality and of the correct size for the needle (see page 16).

**Stitches Looping.** This is due to incorrect tensions (see page 9). See that both the bobbin case and the needle are properly threaded; that the thread used is of good quality and of the correct size for the needle (see page 16).

## RELATIVE SIZES OF NEEDLES AND THREADS

Sizes of Needles	Class of work to sew	Size of cotton, linen or silk
9	Very thin muslin, cambric, linen etc.	100 to 150 cotton 30 silk
11	Very fine calicoes, shirtings, fine silk goods, etc.	80 to 100 cotton 24 to 30 silk
14	Shirtings, sheetings, bleached calicoes, muslin, silk and general domestic goods, and all classes of general work.	60 to 80 cotton 20 silk
16	All kinds of heavy calicoes, light woolen goods, heavy silk, seaming, stitching, etc.	40 to 60 cotton 16 to 18 silk

# INDEX

Balance Wheel Stop Motion .....	2
To Insert the Needle .....	2
To Thread the Needle.....	3
To Wind the Bobbin .....	4
To Thread the Bobbin Case .....	5
To Take Out the Bobbin and Bobbin Case .....	6
To Open the Shuttle Race .....	7
To Commence Sewing.....	8
To Regulate the Tensions .....	9
To Regulate the Length of Stitch and the Direction of Feed .....	11
To Remove the Work .....	11
To Use the Drop Feed Device .....	12
To Oil the Machine.....	12
To Use the Built-in Sewlight.....	14
Useful Hints .....	15
Relative Sizes of Needles and Threads.....	16



MODEL 620

*Bell Air*

SEWING MACHINE